

PART I

THE EXCAVATION IN THE CITADEL AREA



I. INTRODUCTION

A. THE PROBLEM AND THE APPROACH

In view of the cultural importance of the ancient State and City of Mathura known to us from literary sources as well as from the vast material of stone sculptures, architectural pieces, terracotta figurines and objects, inscriptions, coins etc., we have to face that the archaeological research in this region lags far behind. The images handed down to us tell of a rich religious life in the early historical period in which Buddhism, Jainism, Hinduism and Folkcults competed with each other. But there are no structural remains extent enough for a re-assessment of the antiquity of Mathura and the nature of early historical settlements in its environments. This disappointing situation is, naturally, not to be overcome by a few new small-scale excavations, but only a more purposeful attempt in a larger project might help to throw some more light on the dark period of early Mathura.

With these ideas in mind we decided to undertake something in this direction. Representing the Indian Art and Archaeology research Team of the Museum für Indische Kunst in Berlin we approached as early as 1964 the then Director General of the Archaeological Survey of India, Sri A. Ghosh, for the permission to carry out excavations in Mathura District. In the hope of a decision in favour of our application

mentioning the exact site the realization of the idea seemed to be within reach.

The first question was which of the numerous sites surrounding the city should be selected for excavation. As it was our main interest to find some larger areas of architectural structures of the early period of the old Mathura State, it seemed to be advisable to look for comparably undisturbed mounds in the surroundings instead of those in the city itself (Fig. 1). And among all the promising places visited and discussed in the company of Dr. N. P. Joshi, the then Curator of the Govt. Museum Mathura, the vast artificial plateau within the fields of Sonkh, fourteen miles as the crow flies from Mathura and some eight miles south of the holy Govardhan, attracted the author as being the most suitable object for excavation (Fig. 2).

In his "District Memoir" of Mathura (3rd ed. 1883: p. 383) F. S. Growse remarked: "This (township of Sonkh) lies immediately under the Khera or site of the old fort, of which some crumbling walls and bastions still remain. It was built by a Jāt named Hati Singh, of the time of Sūraj Mall of Bharatpur, or Jawāhir Singh; *but the khera itself must be many hundred of years older*". Exploring the top of the mound, Growse's opinion could easily be confirmed by a large number of surface finds of sherds of the Painted Grey Ware and later potteries, of Śuṅga, Mitra and Kuṣāṇa terracotta objects and small fragments of

Kuṣāṇa stone sculptures. As realized later, these items were thrown up to the highest point when a large and deep moat was dug in the 18th century. Thus a collection of the contents of the site was presented to us in a most unusual way indicating that an excavation at this place was bound to be successful.

Although the contours of the mound clearly betray a citadel upon the wide plateau, the expectations were, for a short time, misled by the recollection of an important sculpture *said* to come from Sonkh, i.e. the fragment of a Cakravartin Buddha latest known date of Kanīṣka I, the year 23 (Lüders 1961: §136). As during eight campaigns of excavations nothing Buddhist has been found in this site, we doubt if the, in any case uncertain, provenience "Sonkh" given for that sculpture is correct.

B. REMARKS ON THE NAME AND THE HISTORY OF SONKH

The name SONKH is, in all probability, younger than the ancient settlement on this place. There is no seal or inscription mentioning the old name as, e.g., is the case with the neighbouring village of Aring obviously being so fortunate to have preserved its original designation. For Sonkh, we do not have any source to bring light into its earliest history except archaeological excavation. Even for the later periods we are more or less dependent on hearsay. It was, nevertheless, interesting to observe that the "local tradition" on which F. S. Growse based his notes on Sonkh is still alive with the younger people in the town. Among the more ignorant villagers the absurd story that Sonkh is the place where the demon Śaṅkhāsura lived is as current at present as in Growse's time. But there are still people who retain scraps of information on Sonkh which are worth to be taken as serious. According to Mr. Biri Singh, a teacher in the I. A. College in Sonkh, this place was called Tomargarh in the 8th century AD but named Sonkh in the 11th century after Sonak Pāl, a Tomar Thākur from Delhi. For F. S. Growse this Sonak Pāl was a Sohan Pāl about whom he says (p. 345): "Sonkh, Sonsa, and Sonoth, all three places in the immediate neighbourhood, would also seem to be named after him and to prove that he was an historical personage of at least considerable local importance". Growse has probably heard nothing of a Tomargarh and dates his Sohan Pāl obviously in the 8th century when he, elsewhere in his book (pp. 382–83), says "according to more genuine local tradition,

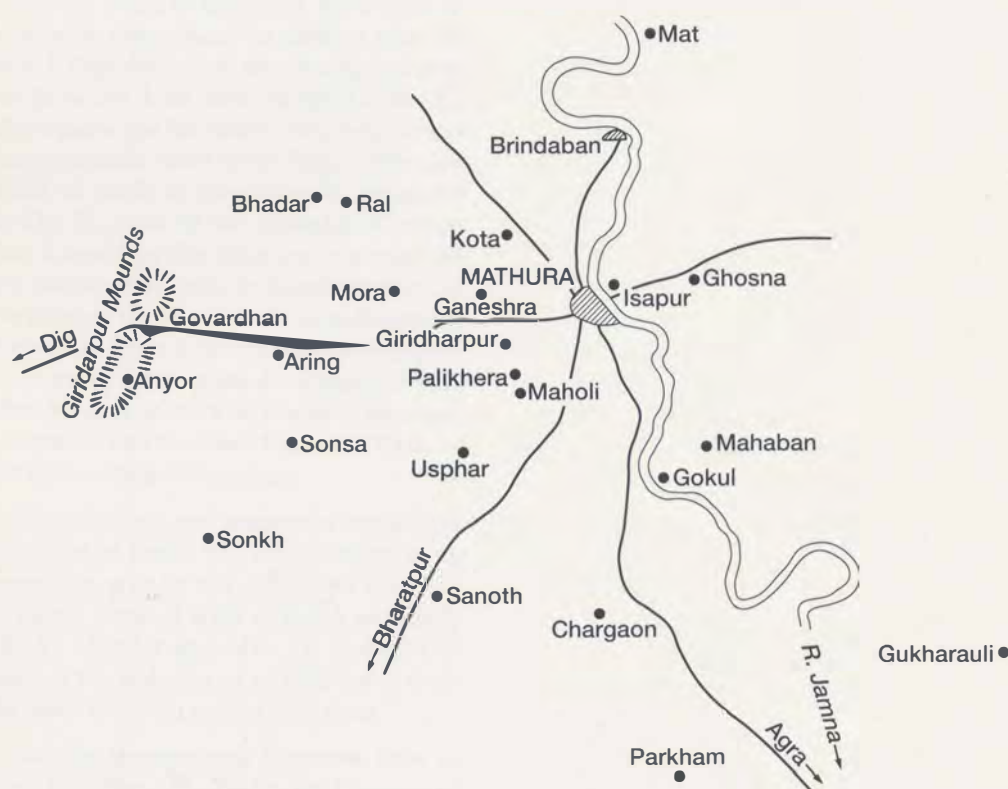

1 Mathura and surroundings



2 General view of the mound, looking south

(Sonkh) was first founded in the time of Anaṅga Pāl, the rebuildler of Delhi, probably by the same Tomar chief who has left other traces of his name at Son, Sonsa and Sonoth". We are, regrettably, not in a position to clear the contradictions on these informations about the history of the place of Sonkh in this period but would like to point out that the Tomar dynasty knows also an Anaṅga Pāl II (AD 1049–1079) and Anaṅga Pāl III (AD 1128–1149).

Other records concern the more recent history of Sonkh, the period of the Jāts. According to Growse the "old fort" was, as already quoted, built by a Jāt named Hati Singh, of the time of Sūraj Mall of Bharatpur, or Jawāhir Singh. We have reason to assume that the Jāt mud fortress of Sonkh was built at the same time as the rubble-and-mud citadel of Dig under Badan Singh (1722–56) by his son, the then prince regent Sūraj Mall. Sonkh is also mentioned as one of the four strongholds of the Jāts in the reign of Aurangzeb (Qanungo 1925: p. 341). This fortress of Sonkh finally stood in the centre of fierce battles fought be-

tween the Marāthās, Rājputs, Jāts and the Mughals (Qanungo 1925: pp. 231 ff.; J. N. Chaudhuri 1977: p. 160) which brought about its end in ca 1775.

These are all informations available about Sonkh. Would we know the ancient name of the locality the situation might be different. But thus it needed the excavations to prove that this place had a hoary past, reaching back far into the first millennium BC.

C. THE SITE AND THE EXCAVATION PROCEDURE

The site of Sonkh, 27°24' North Latitude and 77°30' East Longitude, is located in Mathura District in Uttar Pradesh. To visit the place from Mathura one has to take the more direct road to Kumbher (25 km) or the detour via Aring and Govardhan (32 km).

As one approaches Sonkh the mound would be seen jutting out against the horizon from far. The site consists of a plateau which originally was of the size of at

least 200000 sqm, but is now diminished to a large extent. However, an area of 320 × 280 m, i.e. about 90000 sqm, of the old mound still exists surrounded by fields in the west, north and east. To the southwest the plateau ends rather abruptly on the main road from Govardhan to Bharatpur. South of this road, the wide-spread village of Sonkh, population about 6000, extends on the spur of the ancient mound. Farther north and north-east of the plateau the ground is rather fractured by the clearing away of a tremendous amount of soil for the construction of the canal running in a bow from north to east along the outskirts of the plane. This canal is in all probability following the line of an old riverbed bounding the site at least in the early historical period as suggested by the structural remains on the small area of ancient ground preserved within the fields like an island (see Part II, Introduction).

In the south the plateau is dominated by an elevation rising ca seven to eight metres above the plane area of the site representing in its upper levels generations of fortifi-



3 Trench 1, looking north

cations built one above the other. This citadel construction covered by hard weatherworn mud measures ca 105×90 m and shows at its corners the contours of towers. Into the eastern slope, near to the south-east tower, a large breach is made, washed out by the rains and used nowadays as a path up to the top of the mound. This breach is most probably connected with the construction of a new entrance gate in the last phase of the citadel.

Of the four sloping sides of the citadel elevation the northern fringe appeared to be the least disturbed one. To get an idea of

the successive levels covered by the mound, this was the most promising place to make a vertical cut, touching the highest point of the citadel and leading down to the natural soil in a terrace-like partitioned trench. Thus a 36×5 m long trench, i.e. Trench 1, was laid in the area 2 V/Ca till 3 I/Ca, penetrating the citadel elevation in a depth of only 10 m, but cutting 26 m into the plane towards north (Fig. 3). The upper part of this Trench 1 reaching into the slope of the elevation revealed fragmentary walls of structures built one above the other dating from the 19th century on top down to



4 Profile of moat of Level 4 crossing Trench 1

the late Kuṣāṇa structures at the foot of the mound, i.e. in the height of the surrounding plateau.

The longer part of the trench laid into the plane ground towards north was expected to show the continuation of settlements down to the natural soil. In the beginning this seemed to be a vain hope because for a long time nothing but mud, brickbats and stones without any structural connection came up. Only when a sufficient depth was reached, the riddle could be solved: Along the foot of the citadel elevation a huge moat had been dug in the period of the last fortification (Level 4) throwing the old soil with all its contents up to the rampart and the highest point of the mound (Fig. 4). Therefore this rampart and the finds in it would be a constant source of confusion when excavating the levels in the plane unless we were carefully paying special attention to the respective areas. Fortunately, the trench was long enough to comprise the whole width of the moat and to show the cultural sequence of the levels on the sloping sides of it. On its surface the moat measured 13.80 m, near to the ground, i.e. close to the natural soil, it tapered down to a width of 3.00 m. The preserved complexes of cultural levels to its sides brought us down to the Painted Grey and Black and Red Wares resting on the virgin soil.

The result of this exploration led to the decision to continue the work by horizontal digging in the north-eastern quadrant of the mound at the side of Trench 1. It needed altogether eight campaigns of terracewise excavations in this limited area to unearth the ancient witnesses of this place as reported and discussed in the stratigraphic chapter below (Fig. 5).

D. SURVEY OF THE AREA AND PREPARATIONS FOR EXCAVATION

As it was found out by the ground-research survey and the trial trench of the first campaign (1966/67) that the mound of Sonkh represented a multi-layered site worth to be excavated on a larger scale, preparations for a horizontal digging had to be made.

A topographic survey was started by a surveyor (Dipl. Ing. Walter Fauer, Berlin) to get a contour plan of the mound of Sonkh and the surrounding area resulting in a plan drawn in the scale 1:1000 (Fig. 6).

The contour lines are given at 1.0 m intervals, the 10.0 m lines given in thicker, the 5.0 m ones in dotted lines.

The datum point as main site control point was set arbitrarily due to the lack of a point of known elevation above mean sea level.

The highest point reached in the citadel elevation is about 32.30m, the surrounding planes at about 23.00–19.00m, the lowest level reached in course of excavation about 12.00m.

The surveyed area extends from a section of the Govardhan-Bharatpur road south of the mound about 700m towards north and, starting about 100m west of the mound, for a distance of about 600m to the east. To the north-east the boundary of the surveyed area was formed by the modern canal. Thus a plan was prepared including the mound of Sonkh, the small island of the Cāmuṇḍā temple north to the main excavation area and the surrounding region so far important.

For the purpose of excavation an overall grid system was designed for the whole area, basis of division being 100m squares. Numerous cemented bench marks as site control points were set in the area of excavation, their position coinciding with the points of intersection of the 100m squares, marked by numbered circles and giving the respective height at the above datum point. The orientation of the survey map and the plans of the excavation was agreed upon as true north being at the top of the plans. The northern direction has been fixed by measuring the pole star, making allowance for the deviation from the geographic North pole.

The 100m squares were marked, starting at the south-western corner, by numerals 1–8 in south-north direction and by letters A–G in the west-east direction. For ease of recording within these basic squares a grid system was devised by dividing the 100m squares in 20m squares, carrying each in south-north direction the Roman numerals I–V, in west-east direction the small letters a–e, e.g. giving the designation of the first 20m square as 1 I/Aa and so on.

So that all the data could be easily recorded, and all the finds unearthed in their respective area were correctly labelled, measurement started always at the south-western corner of a 20m square or sub-square in northern resp. eastern direction. A measured point will thus have e.g. the data 2 V 12.50m / Ca 9.20m, accompanied by its height according to the bench marks. As the 20m squares were still too large for actual excavation work 10m squares were chosen as the working unit. The ground of the excavation area was pegged out, the nodal points of the 20m and 10m squares respectively marked by wooden pegs, diagonally posed, giving the designation of the square under excavation.

For the measurement of the excavated structures, and to establish the exact posi-

tion of major excavated objects, the method of geometrical triangulation was used, height data were measured as far as possible by use of theodolite and levelling rod.

The width of the vertical working balks, taken down after recording the results of the excavation work, was chosen to be 1.0m, giving as inner field of excavation an area of 9.0 × 9.0m. For the study of the sequence of levels the inner eastern and southern sides of the working squares were recorded. Apart from detail drawings, the scale of plans and sections is 1:50 uniformly.

The north-eastern corner of the citadel elevation was chosen as the main excavation area. The western profile of Trench 1 and its prolongation towards south-west, running in a deviation of 17 degrees to the south-north direction, was taken as the western boundary of the selected area. The southern border was chosen, starting approximately in the centre of the citadel, running south-east in a deviation of 21 degrees to the west-east direction. The western and southern border lines of the excavation area are meeting thus in an angle of 94 degrees.

In the beginning the total area under excavation was about 50 × 48m, i.e. about 2400 square metre, reaching in its larger extension in course of excavation an area of about 4.800 square metres, not including the site of the Apsidal Temple no. 2 (see Part II).

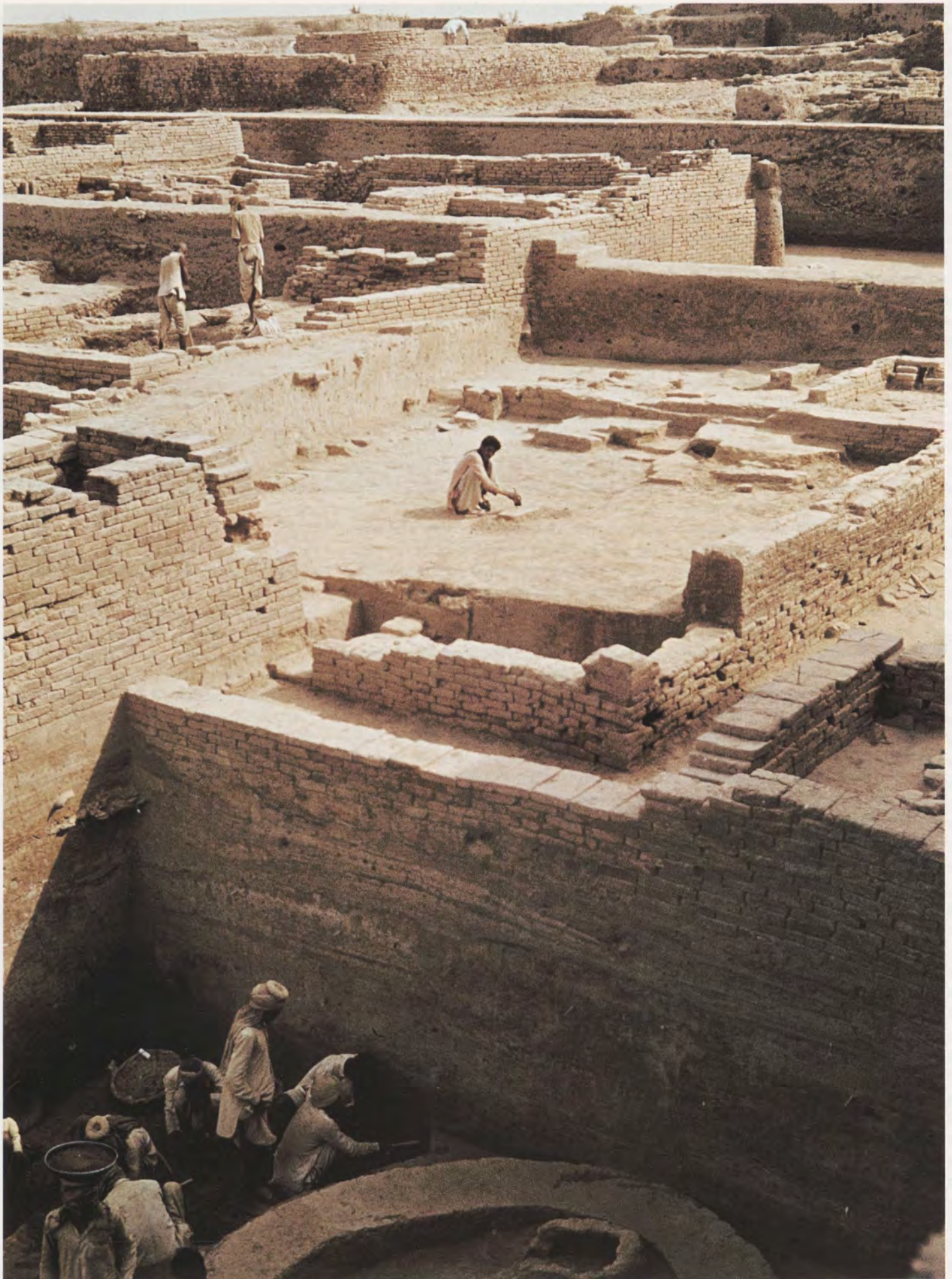

5 Terraces of excavation, Levels 36 to 16

E. SUMMARY OF THE RESULTS

Period	Level	Sub-Periods	Cultural Equipment
VIII	1	Late Fortress Levels Moghuls to Jāts	Black-on-red painted pottery. Moulded grey and red jars and bottles with relief décor in Levels 8 to 6. Appearance of hookah.
	2		Successiv fortresses in Levels 7 to 5. Mud fortifications and large moat in Level 4.
	3		Arrow-heads, clamps, cannon balls of iron; rings of copper.
	4		Terracotta male figures and riders. Hollow animal figurines.
	5		Terracotta objects: spindle-whorls, balls, toy-guns.
	6		Satti-satta stone reliefs; large stone bowls.
	7		Beads of shell only.
VII	8	Medieval Levels	Quantity of pottery finds considerably reduced. Types of Period VI continuing. Décor mainly of black painted stripes, swans and peacocks. Cone lid with knob replaces bell-shaped and bowl lid. Appearance of thin grey ware, white-slipped, incised and painted.
	9		Alignment of buildings from now diagonally to the cardinal directions. Caravansera in Level 11. Levels 10 to 8 developing residential areas again.
	10		In Level 8 four coins of Sher Shah Suri.
	11		Rods, nails, chain of iron; plate of copper; ring of brass. Terracotta female figures and fragments of satti-satta plaques. Few animal figurines. Terracotta discs, spindle-whorls, game-pieces, balls. Last specimens of grey stone plaques depicting deities in Level 11. Long pestle, hammer stone. Beads as in VI.
VI	12	Gupta to Early Medieval	Red, mostly red-slipped ware, delicately thrown, smooth surface, distinct black horizontal stripes. Later on black painted swans and floral pattern. Moulded bowls with relief ornaments; goblet with moulded bowl and stem. Bottles with sprinkler necks and spouts.
	13		From Level 15 upwards strongly disturbed building area.
	14		Arrow-heads, rods, tubes pincers, chisel, nails, hooks, chains of iron. Dish, bottles, wire of copper and brass.
	15		Terracotta female figures; fragment of a larger relief with Makara. Horse and humped bull most favourite terracotta animals. Votive tank and water jug. Terracotta objects: wheels, discs, spindle-whorls, dabbers, game pieces, balls. Grey stone plaques depicting deities; trays. Rotary quern of stone. Beads of usual materials except copper. No incised types.
V	16	Kuṣāṇas	Red ware with the characteristic Kuṣāṇa stamping of storage vessels, jars etc. with symbolic, floral and geometric ornaments. Moulded small bowl. Spouted water jars.
	17		Seven levels showing more or less densely built up area of houses. Occasionally working area without building. Apsidal Temple no. 1 in the habitation area.
	18		Coins of Wima Kadphises, Kaniška I, Huviška, Vāsudeva and successors.
	19		Bronze figures of Skanda and a deitie couple.
	20		Arrow-heads, spear-heads, knives, sickles, clamps, rattle bell of iron; cart, antimony rods, bangles, rings of copper.
	21		Terracotta human figurines, depiction of gods and goddesses. Animal figurines, mostly humped bulls. Inscribed seals; coin moulds; pottery stamps. Votive tanks. Usual terracotta objects.
	22		Stone sculptures and reliefs. Trays and caskets. Inscribed stone fragments. Mill stones as before. Bone styli; shell bangles. Beads of all materials and types, including such of lapis lazuli and incised and etched types.
IV	23	Kṣātrapas & Rāmadatta	Red ware, characterized by definite differences in the shapes. Globular water jar, small goblet, beaker. In the end of this period the fashion of stamping the vessels with symbols begins.
	24		Houses now built in sections and protected at street-corners with large stone blocks. House with bathroom and toilet. No roof-tiles anymore. Coins of Hāgāmaṣa, Rājuvula, Śoḍāsa, Rāmadatta. Arrow-heads, spear-heads, knives, chains, rods, clamps, spoons, ladle of iron. Goblet with bowls of copper. Terracotta human figurines, Kṣātrapa type of mother goddess. Humped bull most favourite animal. Votive tank with seated mother goddess figures. Terracotta objects as before. Inscribed seals. Stone objects: mortars, ring-stones, dabbers, pestles, Caskets. Inscribed fragments. Bone styli; shell bangles. Beads of all materials except lapis lazuli. No incised and etched types.
III	25	Mītras of Mathura	Red Ware types continuing. New shapes, esp. ovoidal storage jars with appliqué cordons and symbols (svastika, nandyāvarta). Handles in shape of monkeys.
	26		Beginning of baked brick construction in Mitra Level 27. Regular town planning.
	27		Houses constructed by grouping of rooms around an inner courtyard. Terracotta ring-wells in private houses. Gable roofs with roof-tiles and pinnacles. Inscribed copper coins of Gomitra, Sūryamitra, Brahmamitra, Viṣṇumitra.
	28		New: spear-head, sickle, brand-iron, ring of iron; hook, toggle, ring, antimony rod and wheel of copper; bracelet, bangle of brass. Terracotta human plaques, animal figurines (mainly elephant and horse). Square and round votive tanks to be filled with water. In addition to Period II terracotta toy-carts, dabbers, rattles, amulet and pendants. Inscribed seals. Stone objects: rectangular quern plates, pestles, dabbers, discs, balls. Stone caskets. Bone styli, shell bangles. Beads of all types and material except lapis lazuli. No etched and incised beads. First appearance of faience.
II	29	Śuṅga Cultural Phase Maurya Pre- and Early Maurya	Northern Black Polished Ware; coarse grey ware; black-slipped grey ware; ordinary red ware. Fashion of terracotta heads on shoulder of vessels. Animal-shaped vessels.
	30		Mud wall structures in Levels 36–30. Beginning of mud-brick construction in Level 29. Fragment of mosaic.
	31		Silver and copper punch-marked coins; unscrubbed cast and die-struck coins.
	32		Arrow-heads, rods, nails of iron; bracelet of copper.
	33		Terracotta human figurines, mostly black-slipped, in later phase of period in shape of reddish plaques. Terracotta animal figurines, elephant most favourite.
	34		Fragments of round votive tanks. Terracotta wheels, discs, spindle-whorls, skin-rubbers, reels, game pieces, plain and decorated balls, bangles. Jewelry mould.
	35		Stone quern tables, balls. Anthropomorphic bone figure. Beads of all materials except lapis lazuli, faience, blue, black and yellow glass and gold-foil.
I	37	Painted Grey Ware Black-and- Red Ware	Painted Grey Ware and, to a lesser degree, Black and Red Ware. Black-slipped Ware. Ordinary red and red-slipped ware. Vessels partly decorated with incised, impressed or applied patterns. At the end of the period coarse grey ware.
	38		No mud or mud-brick walls but post-holes and reed impressions. Brick-like pieces of mud from fireplaces. Two ditches with small rampart in between, perhaps part of the northern enclosure of the habitated area.
	39		Iron arrow-heads, blade of an adze or axe.
	40		Fragments of terracotta animal figures; discs, plain and decorated balls, bangles. Beads of carnelian, agate and copper. Hammer stone.
			Natural Soil

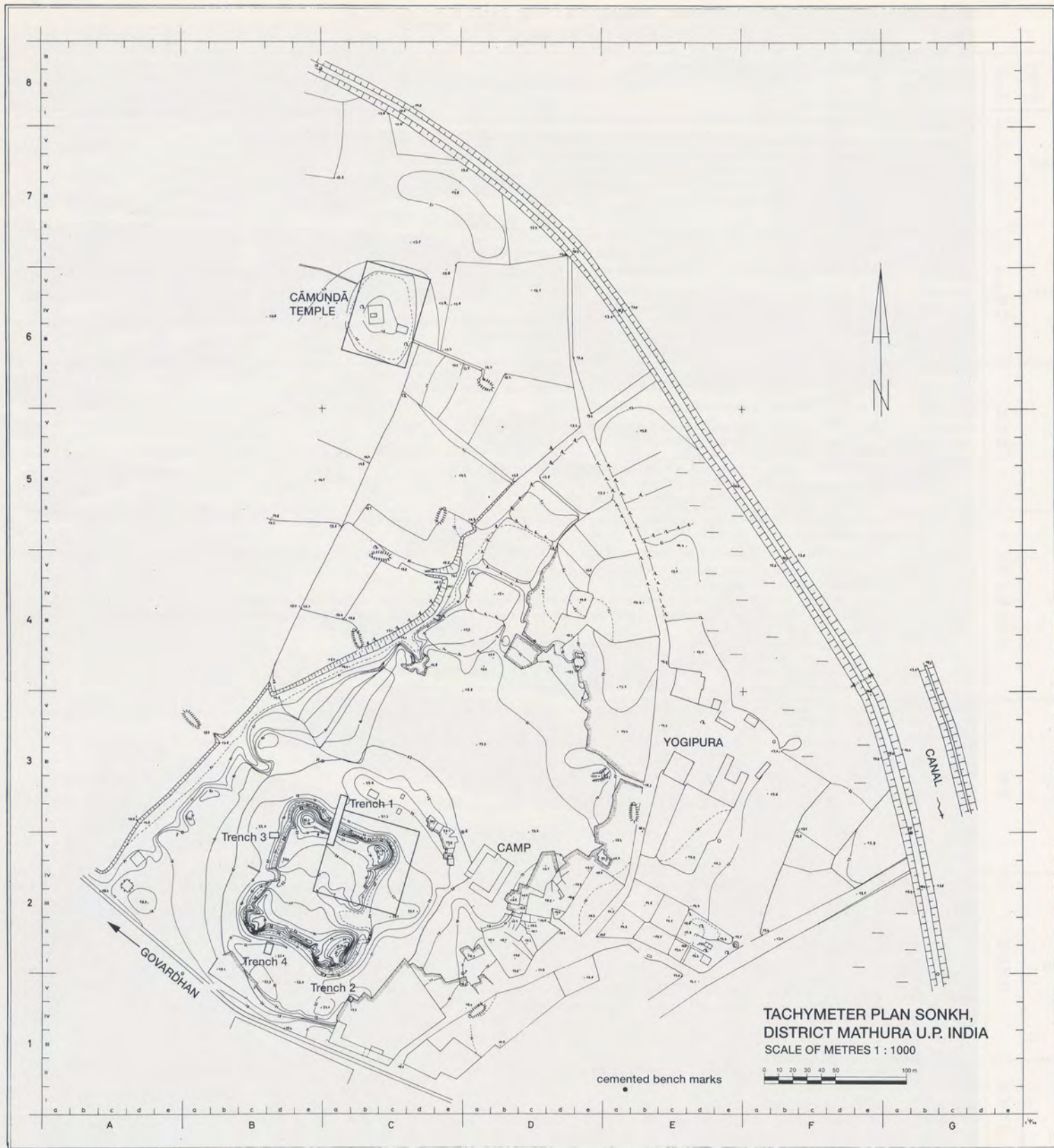

6 Tachymeter plan of the mound of Sonkh

II. GENERAL SITUATION OF THE TRENCHES

In course of the eight excavation campaigns the stratification of the earlier phases of habitation was examined in trial trenches in several places within the excavation area and its surroundings. The main attention was directed to the Painted Grey Ware levels as well as to the formation of archaeological remains upon and above it, beginning with the Early Maurya level 36 and reaching upto Level 27, the structures of which were exposed at first in a larger extent. The position of the trenches and their extension are documented in the surveyor's plan (Fig. 6).

The extension of Trench 1 and the layout of the trenches within the later excavation area, squares 2 IV/Be and 2 IV/Cc, during the campaigns 5 to 8 had to take in account the already exposed structures of the Kuṣāṇa period in 2 IV as well as those of the Mitra level 27 in 2 V.

Trench 2 was dug in the precincts of a cut-off part to the south of the citadel. Trenches 3 and 4 are situated at the western and southern slope of the ramparts of the citadel elevation. These trenches provided sufficient information on the extension of the levels and the structural and chronological succession of the early epochs of habitation below the well exposed Mitra level 27. The area covered, i.e. enclosed by the trenches has an extension of 150m in the north-south direction and 90m from west to east.

In all the trenches natural soil was reached underneath the lowest level of PGW. To be on the safe side, the soil was examined in parts down to a depth of 3.0 metres. However, no traces of older habitation phases could be made out.

In some places a sharp line was marking itself between the ochre to reddish-yellow, slightly loamy, sandy ground of the PGW levels and the more whitish-light grey to yellowish sand of the natural soil which is mixed with mica and kankar; but in parts a gradual change could be ascertained as well.

A. THE TIME OF THE PAINTED GREY WARE

1. The Trench 1 and its Extension

In the first excavation campaign of 1966/67 a trench of 36.0 by 5.0 metres was laid in the squares 2 V/Ca to 3 II/Ca (Härtel 1967 and 1968) cutting down through the northern slope of the citadel elevation

(Fig. 3). In the northern part of Trench 1 the natural soil was reached on an area of ca 75 sqm. The ceramic finds of the Painted Grey Ware period, the levels of which lay directly on the natural soil, were surprisingly extensive in spite of the rather limited dimension of the cut. This has to be attributed for the most part to the exposure of a ditch belonging to this time, the course of which is crossing the trench (Fig. 4). To corroborate the information so far gained and to integrate the trench into the grid system of the excavation, an extension to ca 240 sqm was started in the campaign 1970/71 (Härtel 1972).

The average thickness of the culture levels of the PGW period was 1.0m in the region of Trench 1. The upper edge of the natural soil rose from ca 14.25m in the northern to ca 14.50m in the southern part. The upper limit of the PGW levels was reached here, in the undisturbed area, at ca 15.50m. Within this stratum of rather uniform consistency (see below) could be ascertained the remains of diverse superimposed levels of habitation partly coinciding with thicker layers of sherds. Together with the typical PGW, which gave the name to this period, sherds of Black-and-Red Ware (BRW), Coarse Grey Ware as well as partially decorated Red Ware were found in all spheres of the PGW levels.

Level 40, Phase 1 and 2

Running parallel, two ditches of different width cut through the excavation area from WNW to ESE in the northern part of Trench 1 (Fig. 7). They were sunk directly into the natural soil in the first dwelling phase of the mound of Sonkh. The bigger ditch, partly more than 2.75m wide at the top, upper edge at about 14.50m, was ca 2.20m deep ending on a level of ca 12.30m. The bottom of the smaller ditch, ca 0.70m wide, lay at 13.30m, ca 0.80–0.90m beneath the lower outer ground level. The average distance from the middle of one ditch to that of the other, was ca 4.50m, whereas the overall measurement of the ditch system varied between 6.00 and 6.50m. The ground sloped ca 0.25m slightly from west to east in the neighbourhood of the ditches. Correspondingly the bottom of the bigger ditch inclined gradually, it lay about 0.45m higher at the western side. However, it cannot be excluded that these differences in height appear in a small part of the ditch system only. Thus it remains doubtful whether the whole of the ditch system was laid out in the gradient or on a rather even level.

The original profile of the bigger ditch was

almost trapeze-shaped, narrowing to ca 0.60m at the bottom (Fig. 8). The width of the bottom of the smaller ditch was ca 0.40m, the original angle of inclination of the ditch embankments lay at 70° to 80°. Yet, through erosions and partial gliding-down of the loose soil the slopes of the embankments showed rather varying angles of inclination in course of the ditch. Temporary water-bearing can be presumed on account of single firm alluvial layers, but it is rather doubtful whether the ditches have borne water constantly. On the basis of the upper alluvial layers it could be concluded that the ditches later on were flooded from the south and filled up, the surface water streaming in carrying with it the rather loose soil. The area lying between the both ditches was banked up and raised while digging the ditches, the more horizontal line now marking in the profile to be attributed to an erosion.

For this earliest habitation phase as well as for those following of the PGW period no remains whatsoever of structures of mud or mud-brick could be determined in Trench 1. Some post-holes met with in higher levels as well as remains of clay-impressions indicate the use of easily perishable building material. The significance of the ditch system and its relation to the whole habitation area was stressed by the overall situation met with, the alluvial layers of the southern larger 'inner' ditch yielding the greater number of ceramics found in these levels. In addition to numerous sherds of PGW, BRW and ordinary Red Ware, there were found also several larger fragments of vessels and likewise 25 sherds of a bowl (POTTERY I.12) of a coloured variant of the PGW, in a height of 13.05m. Presumably, the bowl which could be completely put together from the sherds, slipped into the ditch at that time water-bearing ditch and broke on the bottom. A vessel of associated Red Ware, 23.0cm high, could be recovered unbroken in the height of ca 13.30m (POTTERY I.49). In the trench area south of the ditches likewise sherds of PGW were found in a range of 14.60 to 14.40m, to be regarded as synchronous with the construction of the ditch system. Rather different was the situation while excavating the smaller of the two ditches and the area lying north of it. Here only single sherds were found sporadically in an average range of 14.20 to 14.40m.

These results, in connection with the form of the ditch system, leads to the conclusion that we have to regard the ditches as lying at the periphery of the habitation, at least in the initial phase of the PGW period. Worth

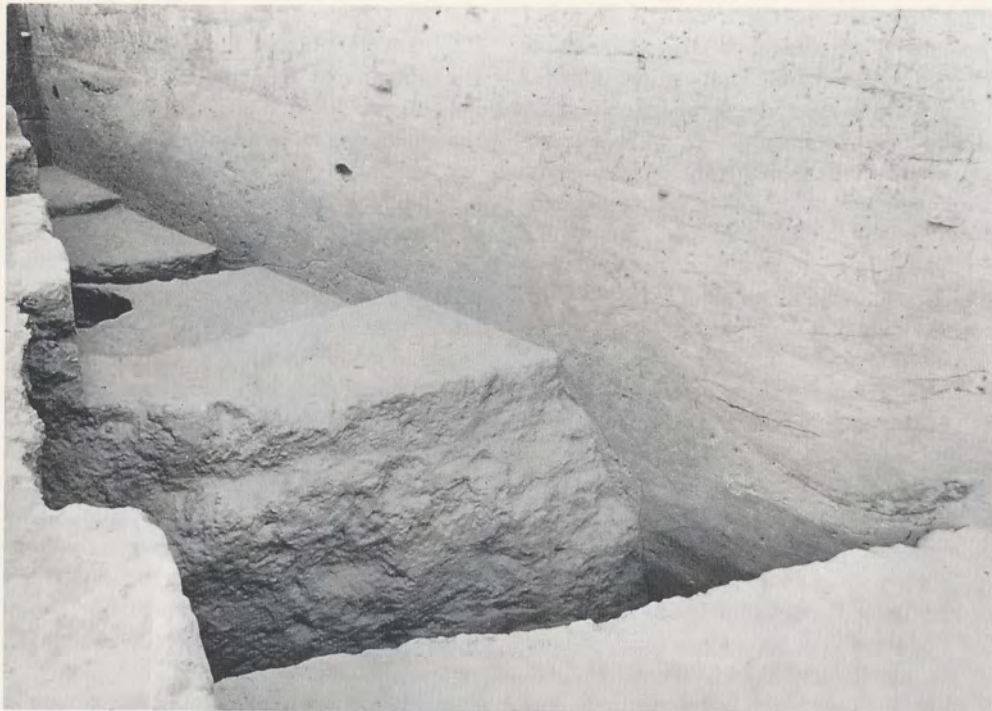

7 View of the two PGW ditches

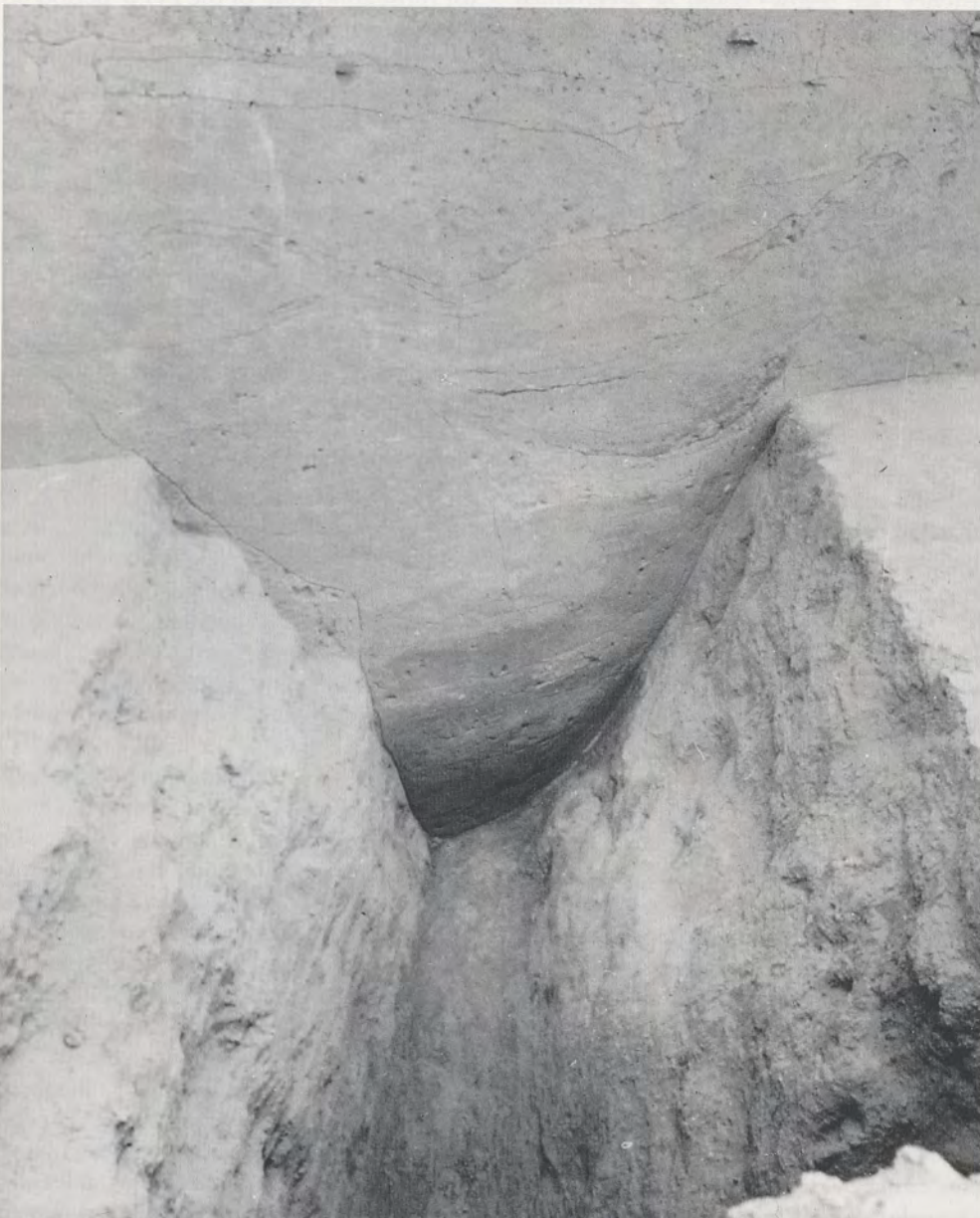

8 The bigger PGW ditch

GENERAL SITUATION OF THE TRENCHES

In course of the eight excavation campaigns the stratigraphy of the earlier phases of habitation was examined in that trenches in several places within the excavated area and its surroundings. The main attention was directed to the Painted Gray Ware levels as well as to the formation of archaeological remains upon and since its beginning with the Early Iron Age. The stratigraphy upon level 27, the structures of which were exposed first in a larger extent. The position of the trench and their extension are determined in the survey plan (Fig. 6).

A cross-section of Trench 1 and the layout of the trenches within the first excavation are shown in Figs 7 and 8. During the campaigns 2, 4, 5 and 6, the trench the already exposed structure of the last part of the period is shown in the plan (Fig. 7).

Trench 1 was dug in the products of a collapsed part to the south of the collapsed Trench 3 and 4 are situated in the western and southern slope of the remains of the dead clayware. These trenches divided the trench into two parts on the eastern side and the trench with clayware fragments of the early periods of habitation below the well exposed M. 1. The trench exposed is enclosed by the trench has an average of 150 cm in north-south direction and 50 cm from east to east.

In all the trenches ground soil was reached and the position of the PGW. In the trench on the east side, the soil was examined part down to a depth of 50 cm. From the east on most of the habitation places could be made out.

In some places a sharp line was found in the soil between the clay to which yellow slightly loamy, sandy ground of the PGW levels and the overlying soil. The soil is yellowish grey of the level 27. It is mixed with mica and kaolin but in places a gradual change was observed as well.

AT THE TIME OF THE PAINTED GREY WARE

1. The Trench 1 and its Extension

In the first excavation campaign in 1955 a trench 10 m by 5 m was dug and the remains of the PGW (Painted Grey Ware) were found through the northern slope of the excavated area.

mentioning in this connection is a general slight ascent of the level by ca 1.0m towards south.

Through erosion and flooding the ditch system seems to have been filled up in relatively short time. Thus an effort was made to erect again a sort of small bullwork, the height of the dwelling level in the southern, inner region still unchanged. The new, rather narrow ditch with a depth between 0.80 and 0.90m followed the course of the larger ditch of the older construction. The bank between the former ditches, eroded in the meantime, was raised to ca 0.50m thereby. The ground extending northwards had raised too so that for the second phase of Level 40 an average height of 14.50m was to be noted for the southern as well as for the northern level. In contrast to Phase 1, an increased accumulation of sherds was to be observed at this height in the outer region as well.

Above the alluvial and filling layers of this second phase of Level 40 several conflagrations and ash deposits, upto 1.00m wide, were found in the ditch area. Of different strength, partly upto 20.0cm thick, they could be followed in the course of the ditch for a length of more than 8.00m. They consisted of several layers of reddish brown to black ashes with scanty remains of charcoal, mixed partly with sand.

Level 39

Within the ca 1.00m stratum rising above the lowermost Level 40, it was rather difficult to gain a clear stratification. The homogeneity of the deposit-layers prevented the tracing of levels over a longer distance. It was only possible to determine a sequence in places of limited, superimposed layers of sherds, ashes etc. Fortunately, this opportunity was given to a certain extent in the northern part of Trench 1 (3 II/Ca). The level of ca 14.80 in 3 II/Ca, ascending to ca 14.85m in the southern area of the trench, must be regarded as new phase of habitation. A big jar of red ware (POTTERY I.40), standing in the ground was found at 3 II 0.2/Ca 17.8. The base lay at 14.80m, directly above a layer of ashes of the filled-up ditch system (Fig.9). The vessel, sunk ca 10.0cm into the soil, was still exposed ca 45.0cm above the level. The rim and portions of the shoulder were broken off on account of the soil resting on them later on, their sherds however were found on the bottom inside the vessel and could be joined on the spot. The excellent state of preservation speaks of a long period of use. The diameter of the jar is 57.5cm, its height 76.0cm (Fig.10). Pre-

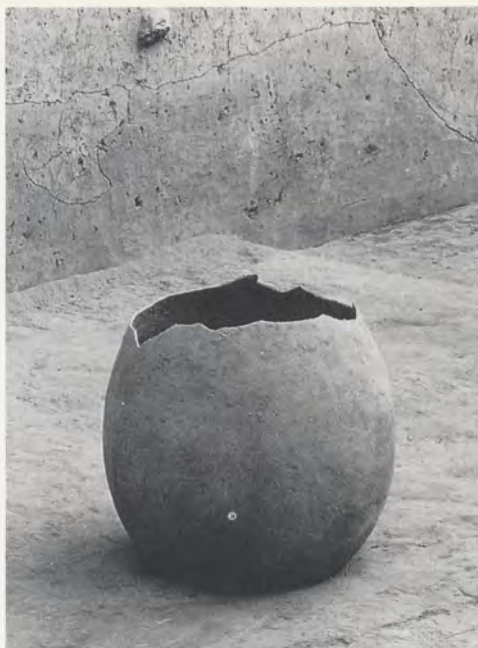

9 Big red ware jar in PGW-Level 39

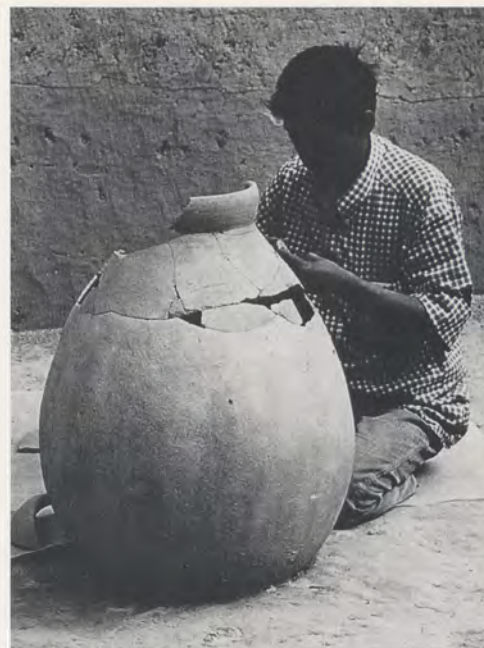

10 Jar of fig. 9 being put together

sumably it was used as water jar because neither any remains of grain nor any residue of decomposition were found inside the vessel. Smaller traces of flow, like a flat gully filled with alluvial sand, to the north of the vessel, support this conclusion. North of the base of this pot, in a height of 14.90 to 14.80m, an intense occurrence of potsherds was to be observed likewise.

A layer of grey-brown ashes at 3 I 17.5–19.0/Ca 18.0–19.5 ascended slightly towards south from 14.70 to 14.95m. The

average thickness of this layer, a mix of rotted remains and sand, amounted to ca 10.0cm. Also belonging to this level is a layer of sand in 3 I 6.5–15.0/Ca 13.5–19.5 with an average height of 14.85m. Irregular depressions with diameters between 10.0 and 35.0cm of various depths (post-holes), filled up with brownish loamy sand, as well as some smaller gullies make it possible to fix this occupation phase. Four small holes, arranged around the bigger depression, resulted in a slightly

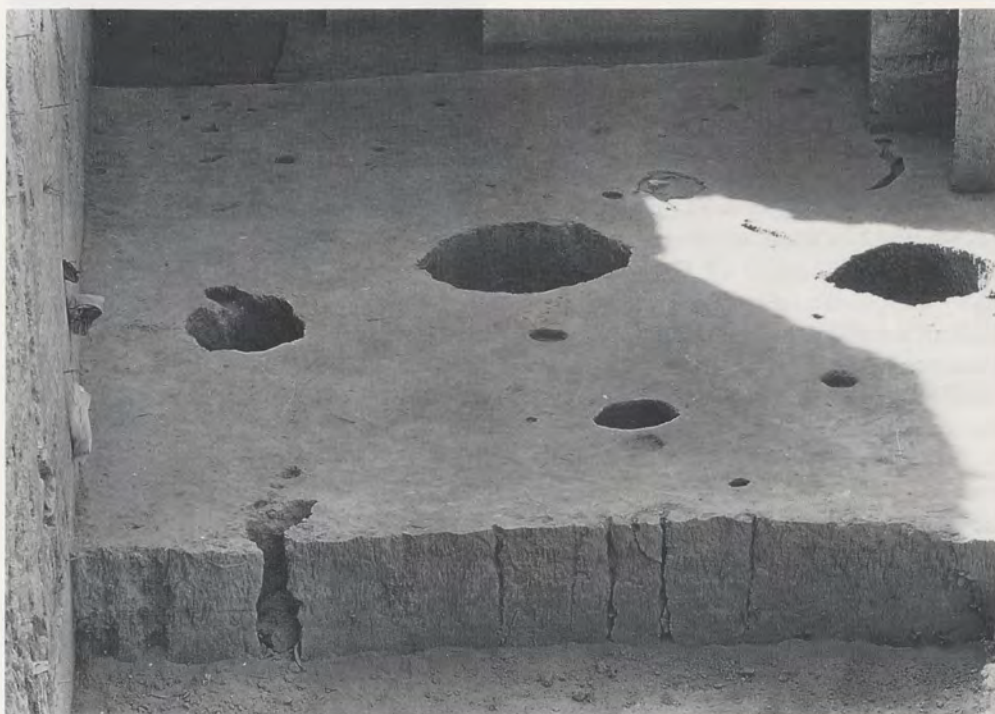

11 Sand floor with post-holes, Level 39

rhombic ground-plan from 2.70 to 2.90 m. Most probably, they are to be regarded as post-holes of a wooden construction similar to a "tent" with central support (Fig. 11).

The charcoal specimen, collected at 3 I 11.5/Ca 14.2, H. 14.80 m and to be assigned to this level showed for this height a date of 695 cal BC (see CHRONOLOGY).

Level 38

Level 38 could only be marked out in the region of 3 II 6.25–7.7/Ca 13.5–17.0. Remains of animal bones together with ash spots and traces of conflagration near the fragments of vessels allow to consider this area with an average height of 15.00 m as a habitation level. To the south of this field, at 3 II 5.9/Ca 14.5–15.5, were found at the same height some burnt red lumps of clay, most probably remains of fireplaces.

Level 37

The uppermost occupation level, ascertained within the PGW period, lay at a height of 15.20 to 15.30 m. In the northern part of Trench 1, at 3 II 4.5–7.0/Ca 15.5–18.0, a fireplace of loamy-clayey sand was exposed (Fig. 12). The slightly oval, ca 55.0 cm wide and 70.0 cm long construction was situated on a level of 15.25 m average height. The fire-pit was sunk 8.0 cm into the ground. Its bottom as well as the inner sides of the ca 10.0 cm thick and 12.0 cm high walling were reddened by burning. This walling is likely to be considered as horseshoe-shaped, in spite of partial destruction. To the south of the fireplace, at a distance of ca 0.55 m, was situated a 25.0 cm deep pit, diameter 75.0 cm. Its filling consisted of darkish yellowish brown and loamy sand with some rotted remains. The significance of the pit in connexion with the fireplace remains unclear. In the neighbourhood (3 II 7.0–7.7/Ca 13.5–14.5) was ascertained in a height of 15.20 m a thin layer of rotted remains of plant origin. To the west, bordering almost directly on the fireplace, was found a ca 10.0 cm thick layer of ashes, reddish brown to light grey, mixed with sand and rotten material. It extended over the area 3 II 6.2–7.2/Ca 18.0–19.5 in a height of 15.15 to 15.30 m, probably used as a dump for the ashes produced by the use of the fireplace. The upper edge of the destroyed shoulder portion of the big water jar of Level 39, about 6.00 m south of the fireplace, was reached at ca 15.25 m. It cannot be said with certainty whether this pot was continu-



12 Fireplace in Level 37, Trench 1



13 Gully in Level 37, Trench 1

ously used upto the time of Level 37, but a longer duration of use exceeding the period of Level 39 can be assumed definitely. In a height of 15.16–15.21 m a small firm sand-loam level was preserved in the southern part of Trench 1 (3 I 3.5–7.5/Ca 14.0–17.5). In this field a gully was found, 0.40–0.45 m wide and running from NNE towards SSW, in an average depth of 0.20 m (Fig. 13). In contrast to the more yellowish ground it was filled up with sand of whitish colour. A little westward of the gully, at 3 I 6.2/Ca 14.0, a globular jar was found standing in the ground (POTTERY

I.53). Its bottom lay at 15.10 m, the upper edge of the broken rim portion at 15.40 m. The missing sherds, found in the vicinity, could however be joined to it later. It is a 36.5 cm high vessel of Red Ware with dark red vitrified slip. Noteworthy is a stamped potter's mark on the inner side of the rim, a circle with a semicircle opening above, of the height of 0.8 cm. Another sherd (So II 2431) with the same mark, found in the direct neighbourhood, gives evidence for a frequent use of this sign at the time. A nearly round and reddish burnt sand-loam area, diameter ca 0.50 m, was situated a little northwards of the vessel. It could be interpreted as the spot of a fireplace.

The upper edge of the whole, clearly marked stratum of PGW levels did not run quite horizontal in this southern part of Trench 1. At the western side, it lay at 15.50 m, in the central region directly beneath the foundations of the mud wall in Level 35. The lower edge of this foundation, height 15.40 m, corresponds to the upper edge of the vessel described above (I.53), the rim of which had been destroyed during the work for the mud wall. At the eastern side, soil of a different colour lay directly above the Level 37, resulting thereby in a surface slightly sloping from west towards east, of the PGW deposits. The jumble of layers above 15.30 m in the northern part of Trench 1 made it impossible here to pinpoint the upper boundary. Rather there was a picture of mingling and of gradual transition from the ochre-coloured sandy soil of the PGW levels to the more loamy earth of the younger periods coloured dark to an increasing extent and interspersed with ashes.

2. Further Trenches

The different trenches carried out in successive years inside and outside the main excavation area furnished additional informations on the extension and sequence of the different periods of habitation. In the following report they are dealt with in chronological order of their excavation.

Trench 2

Trench 2 lies at a distance of 140.00 m from Trench 1 on the south-eastern rampart of the citadel mound, where a part of it had been cut off by a merchant in recent years. The cut was restricted to 3.00 by 3.00 m, the alignment oriented on the local conditions. Starting at about 17.30, the upper edge of the PGW stratum, consisting here

of the same firm yellowish-ochre coloured sand as in Trench 1, was reached at ca. 16.30m. Besides large numbers of sherds of PGW as well as BRW, single fragments of treated shell and bone were found. At ca 15.30m, the natural soil was reached directly below the lowest PGW level. Rather conspicuous is the conformity in the total thickness of the levels of the PGW period, about 1.00m, as met with in Trench 1.

Trench 3

West of the plateau, directly at the foot of the rampart of the citadel elevation, the Trench 3, 4.00 m wide and 7.00 m long, was laid in west-east direction (2 V/Bd). The excavation of the PGW stratum, upper height at about 16.40 m in this area, brought a rich result in bigger fragments of the typical PGW (POTTERY I.3; 7; 9–10; 14–15). Similarly, besides the normal Red and Grey Wares, sherds of BRW were found as well (POTTERY I.19; 21).

The height of the natural soil of the southern part, lying higher, amounted to ca 15.00m, being bounded diagonally by an embankment edge, running from WNW towards ESE. North of this line the natural soil was secured at ca 14.00m. Due to the limited dimensions of Trench 3 it could not be ascertained whether this had to be regarded as a natural gradation of the site or to be attributed to human activities. There are several reasons speaking for a further ditch system similar to the structures found in Trench 1. Not only that the embankment was running almost parallel to the course of the ditch in Trench 1 but also the alluvial layers marked out in the east profile can be taken as support for this conjecture. They correspond to the typical and unmistakable picture of the alluvial and deposit layers in the filled-up ditch construction of Level 40. As there, several ash layers could be located in the upper third of the levels in Trench 3. In the north-eastern corner of the excavation area a further depression was noted starting from the level 14.10m. As the depression could be exposed only to a small part, it remained unclear whether it formed part of the assumed ditch structures or, more probable perhaps, a sort of well structure, which was filled up with mostly reddish ashes, sherds and rubbish after being out for use.

Within the filling layers of this area were found several big lumps of tempered and fired clay in a height of 14.80–14.20m. Vaguely similar in shape to baked bricks, they are probably to be regarded as remains of fireplaces.

Trench 4

As the last of the trenches laid outside the main excavation site, Trench 4 was measured in at the foot of the southern rampart of the mound (2 I/Bd), about 80.00m southward of Trench 3 and 40.00m north-west of Trench 2. Unfortunately, a part of the deposits of this 5.00 by 10.00m wide trench was disturbed by the large moat, dug in the times of Level 4, partly reaching down to the natural soil and surrounding the whole citadel elevation. The natural soil was reached in the northern part at 15.50m, towards south, the ground rose to 15.75m. The strength of the deposits of PGW could not be determined precisely. The upper edge of the slightly loamy ochre-grey sand-layers was reached in a height of ca 16.45m. Above it, most varying layers were deposited upto ca 17.60m. Between 16.70 and 16.80m, above a dark layer of earth with a few PGW sherds, the whole area was covered by a 10.0–15.0cm strong layer of debris and lumps of fired clay. Within this layer could be preserved several small fragments of clay-daubing burnt red by fire (So III G 168–175), apparently to be regarded as remains of a clay-daubing on canework of the strength between 0.6–1.3cm. The lumps found were of clay of very fine texture. In connection with the slightly concave curvature of the pieces, this indicates that they might be remains of a fine interior daubing of a round house of canework (cp. B. B. Lal 1954/55, p. 13).

Above this layer of burning and destruction followed layers of alluvial sand being interspersed with sandy clay. At ca 17.60m occurred lumps of clay, tempered strongly with fibres of plant, not burnt thoroughly, in the midst of yellowish sand, overlaid by a layer of ashes.

The total number of pottery sherds found was too small to get an exact sequence of the levels with the help of their distribution. However, the BRW sherds were found together with the PGW almost exclusively in the lower stratas.

It seems probable that this area was not colonised for a time. The alluvial layers encountered above 16.80m point to this as well. Through erosion of the settlement area, situated higher on to the north, a gradual elevation of the area took place towards the end of the PGW period though.

Trench Area 2 IV/Be

In addition to the trenches described above it was tried to obtain further informations on the situation of the PGW levels within the boundaries of the main excavation area, without endangering the substance of the



14 Gully in Level 37, Trench 2 IV/Be

structures, worth preserving, of younger levels. In the southwest corner of the excavation field, in 2 IV/Be, the upper edge of the PGW levels was reached at ca 15.95m. The last level of the PGW period was constituted by a structure not to be ascertained clearly in its function like that of Level 37, described above.

In the southern part of the excavated area came to light the remains of a ca 3.00m long gully, 50.0–55.0cm wide and running from WNW towards ESE (Fig. 14). Right and left of its course stood out clearly perpendicular casings 15.0–18.0cm strong, which were burnt red and blackened in part in the inside. The gully was filled up with a more or less 8.0cm thick layer of yellowish white to light grey ashes, the ground burnt strongly red. The upper edge of the casings lay at 15.82–15.99m, partly destroyed by the following level, the bottom at ca 15.80m. The height of the area north of it is to be fixed with ca 15.90m. Below this level no further structures or levels of occupation could be determined. However, in a height of 15.40m a charcoal sample could be taken from the spot 2 IV 8.45/Be 17.50 which produced a date of 648 cal BC (see CHRONOLOGY). The finds, modest occurrence of PGW sherds, offered no help for a division of this

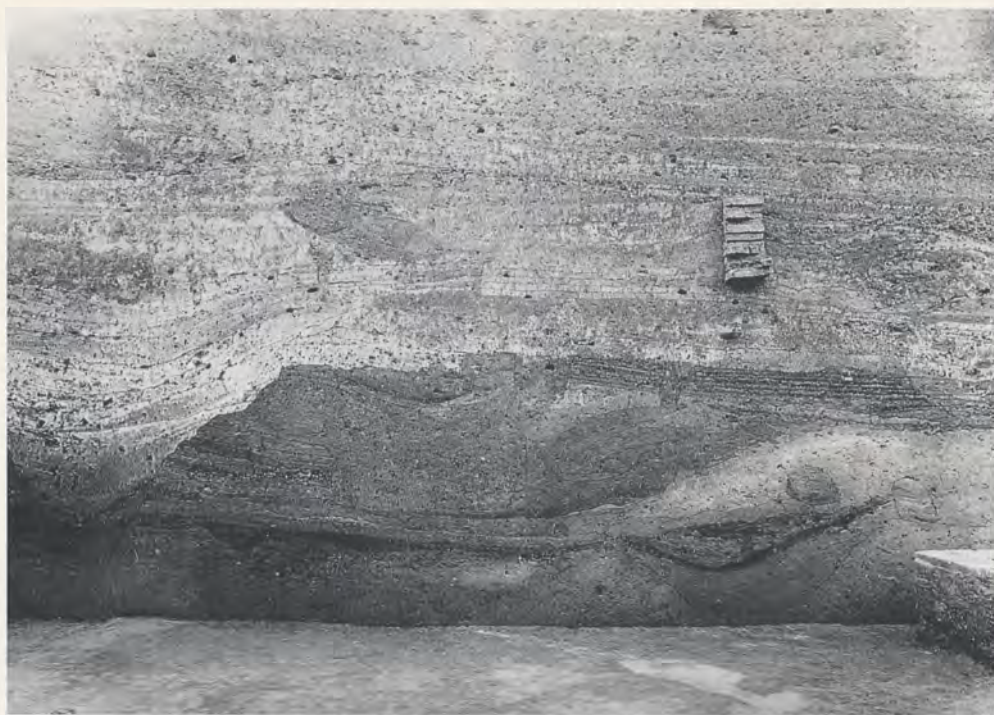

15 Trench 2 IV/Cc. Western profile

package of levels in different occupational phases. Underneath 15.00m isolated sherds were found only sporadically; a gradual transition to the natural soil interspersed with kankar was to be noted.

Trench Area 2 IV/Cc

The 9.00 by 17.50m large trench laid at the eastern side of the excavation area gave some important hints regarding the situ-

ation at the beginning of the occupation of the site. Underneath the earliest building structures, i.e. mud wall structures of the Level 35, exclusively alluvial layers of differing consistence were discovered, their nature could be examined by going down, in some parts, to 12.60m. They formed the filling of a great ditch which ran through this part of the excavation site from NNW towards SSE. Its presumed width amounted to 9.00m, its depth at least

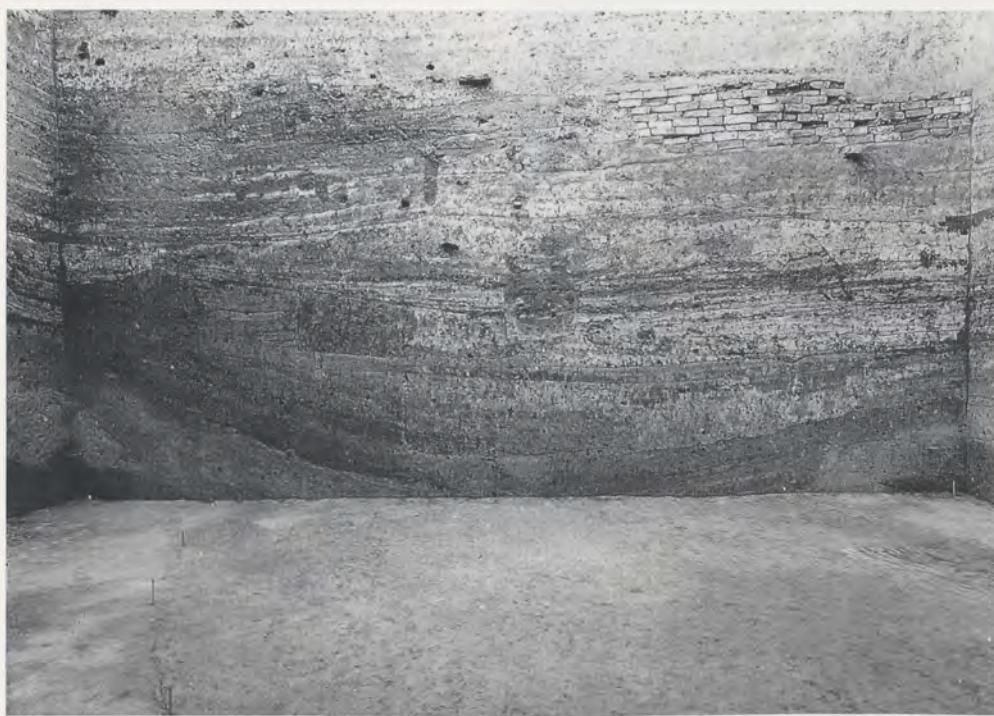

16 Trench 2 IV/Cc. Northern profile

3.50m. Because of the small area exposed and the destruction caused by the moat of Level 4 sunk in in late medieval times, the exact chronological assignment was rendered difficult, there were however some helpful hints in the trench area.

At the eastern side of the ditch, i.e. in the northeast corner of the trench, the original level was found undisturbed in a small area, height 14.60m, upon which later layers in a strength of ca 0.30m, upto the lower edge of the foundation of Level 35, had been deposited. West of this socle of the natural soil, composed of ochre to light grey sand, the slope of the ditch dropped deeply down. In the southwest corner of the trench, only in a small part, sherds of PGW were found. Apart from this, the western side showed bigger erosions and ditch-like inlets, whose alluvial layers alternated with those of ashes and conflagration deposits (Fig. 15).

The lower alluvial layers of the ditch, consisting of a material similar to the natural soil, contained no sherds at all but a big quantity of incrustations. This speaks for the existence of the ditch before the beginning of the settlement of the Painted Grey Ware time, thus excluding that we are dealing with an artificially made ditch, similar to that of Trench 1. It is rather to be regarded as a side branch or an old bed of the river, following the course of which the modern canal was built in later times.

Above the levels of eroded natural soil follows a package of alluvial layers clearly to be assigned to the PGW period, partly mixed with collapsed-in materials of the slope. The river appears to have worked a new course in the PGW era for in this period the gradual filling-up of the old bed was completed (Fig. 16). It could be ascertained with the help of the profiles following the ground surface level of the deposit layers that only in the west of the river(-bed or branch) in course of the PGW period an increase in height, caused by human settlement, of more than 1.0m took place while in this time the height of the eastern area, lying outside, remained nearly unchanged. The slope at the foot of the ground elevated by the deposits of the PGW people, with its angle of inclination of 25°, was covered by an upto 3.0m wide conflagration deposit, height ca 15.50–14.25m, covering the layers of the PGW levels. Upto 5.0cm strong, it consisted of red to black ashes with mixtures of charcoal, the sandy soil below burnt reddish.

It can be presumed that towards the end of the PGW period, when the river was nearly filled up and bigger erosions of the embankment did not occur anymore, a dense

vegetation grew on this slope which was destroyed by fire. A charcoal sample of the conflagration deposit taken at the place 2 IV 15.95/Cc 2.30 at a height of 14.77 m produced a date of 504 cal BC (see CHRONOLOGY).

3. Synopsis

A synopsis of the dates and information obtained through the various trenches yields a general picture which, to a limited extent, elucidates the situation in the beginning of the settlement of the site by the Painted Grey Ware people.

We do not know the reason for a settlement just at this place, but the scenery, which the PGW people found there and which might have contributed to this decision, can be recognised in rough outlines.

The branch of river found in the eastern part of the excavation area crossed the site from NNW to SSE, possibly as part of a meandering river crossing the alluvial plane. The area adjoining towards west rose from northeast (Trench 1) towards southwest uniformly for more than 1.50 m. The highest landmark of the natural soil was reached with 15.75 m in Trench 4. Towards southeast, i.e. the Trench 2, the ground descended slightly. This increase in height let one expect the centre of the settlement in the vicinity of Trench 4 or still further west or southwest, the settlers preferring certainly to erect their homes on a somewhat higher level in order to protect them against possible inundations.

On account of the limited excavated area no remains of structures whatsoever could be unearthed of this earliest occupation of the mound. However, the post-holes in 3I/Ca assigned to Level 39 as well as the remains of daub from a latticed wall, found in Trench 4 and ascribed to the late phase of the PGW period, give indications regarding the prevailing method of construction. The yield of finds in Trench 4 and the area 2IV/Be, i.e. in regions situated more central according to the above-mentioned hypothesis, was very paltry. Rather conspicuous, on the contrary, was the occurrence of sherds on the periphery, in the Trenches 1 and 3 as well as in Trench 2. The abundance of sherds and vessels in the ditch of Trench 1 corresponds with the rich finds in the alluvial layers in Trench 3.

It remains unclear whether the ditch system, to which the part exposed in Trench 1 belongs, had a connection to the branch of river running further eastwards or not. Such a connection would however be imaginable and offer an explanation for the

deeper erosion of the ditch bottom met with at the eastern side of the exposed part. However, a possible turning of the course of the ditch into the southern direction, parallel to the course of the river branch, cannot be excluded totally.

The rather small dimensions of the double-ditch of Sonkh with its slightly raised middle dam in 3I/Ca do not allow us to assume a fortification like that of the early historical time with its parapets and ditches of bigger extent. However, it was part of an enclosure of the first Painted Grey Ware settlement anticipating the elements of later defensive works. It served for the protection of the people living at that time most probably still in tents or in huts made of wood and shrubs with daub as well as for the protection of cattle. Perhaps there was on the crown of the embankment a palisade made of wood and shrubs in order to prevent the intrusion into the area of settlement, yet, it remains unclear to what extent the structure would have served as a safeguard against inundations. So far, the profiles showed no traces at all of a flooding or inundations from the northern side.

For the early Painted Grey Ware period the river branch formed the eastern boundary of the settlement, in the north the settled area was bounded by the ditch system of Trench 1. Even in later times, these boundaries seem to have hardly ever been exceeded towards the east and only insignificantly towards the north. Two small trial trenches to the north brought not the slightest indication of a settlement in this area at the time of the Painted Grey Ware people. The natural border formed by the river bed was overpassed for the first time by building structures in the time of Level 35 attributed to the Maurya period.

The general thickness of the PGW levels altogether varied between 1.00 m in Trench 1 and over 1.50 m in Trench 4. A sequence of levels could not be established with the exception of Trench 1. This is to be assigned partly to the homogeneous soil in the whole of the PGW region and partly to the fact that within the rather spacious area not all parts were densely built upon at one and the same time. In the course of an extensive excavation in the centre of the PGW settlement, i.e. underneath the preserved structures of later levels, different phases of habitation would be found for this early time beyond any doubt.

B. THE TRANSITIONAL PHASE: LEVEL 36

Change of Soil Conditions

The strict separation, ascertained specially in the region of Trench 1, between the soil material of the PGW levels and that of the following levels was confirmed in the other trench areas in course of the excavation. The question arises whether this difference in the soil condition indicates a longer interruption in the sequence of settlement. The following observations may offer an answer.

1. In the area 3 I/Ca yet a ca 20.0 cm thick layer of yellowish loamy sand lay over the ground of the last PGW level. Above this clearly marked layer followed a mud wall structure which had been founded partly into the PGW level. The roof structure of this building had been destroyed by fire.
2. In the eroded area of the ditch in 2 IV/Cc followed above the conflagration deposit several muddy dark grey layers of soil, partly with inclusions of sand, which are to be dated into the Post-PGW period on account of the pottery found there. The depth of this package of layers varies between 10.0 and 20.0 cm at the slope and 60.0 cm in the middle of the ditch. On top of the alluvial layers a mud structure was founded the straw or reed roof of which was likewise destroyed by burning. This conformity as well as the similarity of the find materials allow us to date both the structures in the same settlement phase.
3. In the trench area 2 IV/Be, directly above the last PGW level at the average height of 15.90 m, a hard and greyish mud level with some post-holes was conserved at 15.95 m. Another level followed at a height of ca 16.20 m, showing an oval arrangement of post-holes connected by a groove. The lowermost level with mud wall houses was reached here only in a height of 1.20 m above the last PGW level.

A synopsis of these facts obtained in the various trenches gives support to the conclusion that also in the transitional phase between the end of the Painted Grey Ware time and that of the Early Maurya period the mound of Sonkh was populated without a let-up. The change in the soil conditions seems to signalize no important consequences in the succession of the settlement. The question how far this change has to be seen in close relation with the end of the PGW time or has to be taken as a coincidence must remain unanswered.

The settlement in this transitional phase to the mud wall structures of the succeeding levels, henceforth called *Pre-Maurya*, ap-

pears to have likewise been concentrated in the south-southwestern area because structures of Level 36, belonging to this time were discovered only in 2 IV/Be and not in the areas lying further north and eastwards, a further correspondence with the structures of the PGW time whose centre is to be assumed in this region likewise.

For the area of Trench 1 followed a phase of building inactivity, an explanation why the change of soil is marked here so clearly and undisturbedly. At the same time, the depression still present in the course of the old river branch in the east was filled up further with eroded material containing the terracotta and pottery fragments of the time.

A direct alteration of the building method could not be observed. Similar to the upper PGW levels the structures of this phase are to be imagined as wattle and daub constructions. A ground-plan of such a house was marked in the mud ground of Level 36, Phase 2, as described below. A further indication of the continuance of the cultural tradition, also to be noticed in minor works, e.g. shown in the further manufacture of vessels of the normal Coarse Grey Ware beside a black-slipped variant, were the finds of vessel fragments with a stamped potter's mark. There were samples of this stamping which, although varying in shape (POTTERY II.16), are to be ascribed in their type to those evidenced for Level 37, the uppermost of the PGW levels (POTTERY I.53).



17 Mud floor with post-holes, Level 36/1

could partly be excavated showing a kind of oval shape with outer dimensions of ca 2.50 by 3.50 m (Fig. 18). The otherwise hard and brownish mud of the ground was interspersed strongly with yellowish sand (PGW ground?) within this oval. The depth of the gully, upto 10.0 cm wide, varied between 5.0 and 12.0 cm. This has to be taken as a depression marking the foot-

ing of a vanished hut whose superstructure was of perishable material like wattle-and-daub, the walls slightly inserted into the ground.

The post-holes of bigger sizes in the southwest of the gully may have been the foundation holes of wooden props or supports. Their dimensions not necessarily due to constructional reasons, one might regard them as framing the entrance opening towards southwest. The continuous gully may indicate that the entrance was furnished with a treshold. The smaller post-holes may be understood as indication of a canopy construction in front of the entrance. The strong oval shape of the post-holes prepared in the course of the gully, in one case with a proportion of ca 50.0 by 20.0 cm, catches the eye. The larger diameter here is directed at the centre of the oval. In a second case the inner side was showing a strong angle of slope, possibly an indication for walls inclined strongly inwards.

The post-holes lying outside were all nearly circular, narrowing downwards conically with semicircular bottom. Their depths varies between 10.0 and 15.0 cm. Traces of soot and remains of mud burnt black in the vicinity of a small depression at a distance of ca 1.25 m from the outer edge of the "house" suggest this area as the spot of a fireplace. In a pit 35.0 by 45.0 cm in size and ca 25.0 cm deep situated 1.00 m westward most probably a storage jar was placed.

Structures of Level 36

The discovered traces of structures of this transitional period, taken as Level 36, have to be assigned to two different phases.

Phase 1 consisted of vestiges of a level of brownish grey mud in 2 IV 2.5–6.5/Be 15.5–19.5, with three post-holes in line. Its depth lay between 30.0 and 35.0 cm, with an average distance of 45.0 cm; its diameter amounted to 25.0 cm on the average (Fig. 17). The mud area sloped slightly from south to north from 16.00 to 15.90 m. A little eastward of the post-holes a narrow shallow gully was exposed containing paltry remains of whitish decomposition. On the mud floor beside the post-holes were found some remnants of brick-like material, probably burnt daub.

Phase 2 is to be identified with a mud level which could be followed across the whole excavated area of 2 IV/Be. Its height ranged between 16.29 and 16.21 m. In the northern part of this area a kind of gully



18 Mud floor with oval gully-like deepening and post-holes

C. THE PERIOD OF THE MUD WALL STRUCTURES

From the beginning of the Pre-Maurya upto the time of the Śuṅga Cultural Phase the buildings of the old Sonkh were made of mud walls. Presumably towards the end of Level 36, for the first time, in this region a bigger settlement developed with people settling down, becoming resident. A development which led to the construction of larger houses, built more solid and durable. Thus in this region of rural character the transition from structures of wattle-and-daub or wood to houses constructed of mud walls took place. This transition stage is still noticeable in the ground-plan of the structures, i.e. in the type of round houses typical of buildings made of perishable materials.

Level 35

1. A fair example of this development is the mud wall house exposed in 3 I 3.5–8.5/Ca 6.5–17.5, height 15.40–15.80 m (Fig. 19). The lower outer diameter of this round house made of a mud wall, ca 50.0–65.0 cm thick, varied between 3.50 and 3.65 m. The wall, almost perpendicular on the inside, was outwards, as far as to be ascertained by the 40.0 cm high socle, tapering upwards.

Within the circular building whose foundation height lies at 15.40 m on the average, a mud level was preserved which slopes slightly from west to east from 15.58 to 15.47 m. As the socle of the mud wall rises above this floor between 20.0 and 30.0 cm and no indication could be found of an opening, it must be presumed that there was a threshold to the door, at least 20.0 cm high, which might have served as protection against rainwater oozing in.

The average height of the outer ground-level, identical with the inner floor level, lay at 15.58 m. West of the circular building the level was bounded towards north by a ca 65.0 cm broad mud wall standing up to about 10.0 cm. Presumably it was part of the northern enclosure of a courtyard belonging to the round house, oriented towards south. The socle breaks off rectangularly just 45.0 cm before the round wall creating thereby a narrow passageway. Remains of a mud wall were also exposed in the east directly connected with the circular building taking a course towards north-east.

Irregularly scattered all over the region of the preserved clay-floor were found some depressions and post-holes of different size and depth. One of these post-holes in the direct neighbourhood of the passageway,

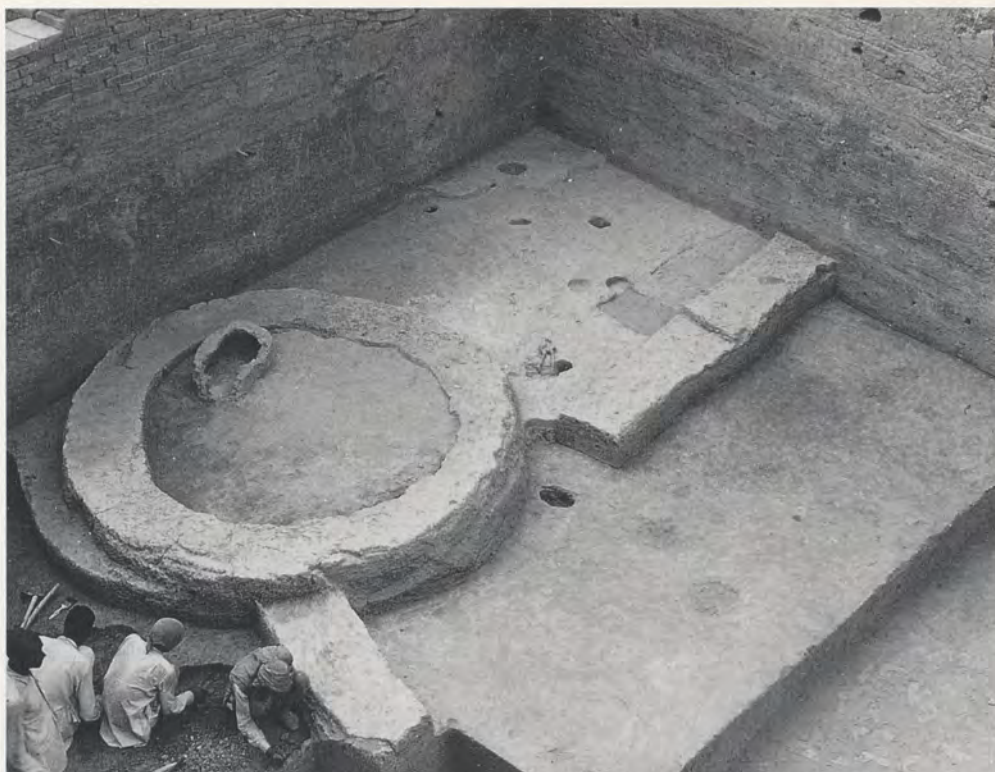

19 Round mud house with post-holes, rotten rope of Level 35, and a fireplace of Level 34

3 I 7.05/Ca 10.65, deserves special attention. The upper diameter of this hole, narrowing downwards conically, amounted to 17.0 cm, its depth ca 25.0 cm. At the edge of the connecting flat pit, diameter 35.0 cm, there was found a noose-shaped object, ca 40.0 cm long and 12.0 cm broad, lying directly on the mud floor (Fig. 20). It consisted of sandy-muddy earth of brownish colour, diameter ca 2.0–2.5 cm. It is obvious that these are the remains of a rotten rope with which the cattle used to be tied to the stake, its place marked by the post-hole. The mud floor, therefore, seems to represent the court area of the property. To the north of its enclosure wall no firm floor was to be determined.

Two-third of the ground of the circular building whose inner diameter amounts to 2.50 m was covered with a deposit of ashes and conflagration, upto 20.0 cm thick. It consisted mostly of blackish-greyish, less reddish ashes mixed with clods of mud. It must be assumed that the roof, made of light wood and covered with grass, was destroyed by fire and its ashes fell into the interior of the house. The clods of mud found there suggest that at least the last "courses" of the wall below the roof construction were composed of a sort of mud-"bricks".

A mud well, discovered at 3 II 3.5–4.4/Ca 17.6–18.3, starting at the height of 15.60 m, can be regarded as belonging to

this Level 35. With an upper diameter of 0.90 m, slightly narrowing downwards, it ended at ca 10.30 m in the ground water-level of the sandy ground. Serving as a rubbish pit after being out of use, it was filled up in the upper part mostly with ashes, bones etc. The excavated material of the deeper section yielded, besides profuse sherd materials, a larger number of undamaged vessels which can be assigned to the early occupational phase of the well (POTTERY II.5; 20–26).

2. Likewise to be assigned to Level 35 are the structures above the filled-up layers of the ditch exposed in 2 IV 12.0–18.0/Cc 2.0–9.5 at a height of 14.34–15.26 m and oriented in east-west direction. The distance between both regions measures 45.00 m, nevertheless, on the basis of the objects found as well as of the correspondence in the destruction by conflagration mentioned earlier, a dating into the same



20 Detail of fig. 19: the rotten rope

period can be regarded as secure in spite of the difference in height of ca 1.00 m due to the level of the ditch. In contrast to the area 3 I/Ca, no circular type but a part of a surprisingly large, nearly rectangular and probably single-roomed mud wall house was exposed (Fig. 21).

At the western side the outer width amounts to 3.80 m, increasing up to 4.50 m towards the centre. So far as it can be recognized, this is to be assigned, at least partially, to a sagging and bulging of the southern wall caused by the settling alluvial layers of the ditch. The ending in the east remains unclear on account of the limited area of excavation, the inner length of the house must have measured at least 4.50 m. The walls, varying in thickness between 40.0 and 60.0 cm, consisted of argillaceous grey mud. Differences in the height of the foundations of the partly 70.0 cm high preserved mud walls were due to the condition of the building ground. The river-bed filled up only roughly with alluvial layers offered no even surface, and a levelling of the ground was obviously not regarded as necessary, resulting thus for the foundations in differences in height of more than 25.0 cm in the east-west and ca 60.0 cm in

the north-south direction. Later sagging could have contributed only insignificantly because the floor within the house shows only minor differences in height.

Yet, the derivation from the vertical line combined with a bulging of the wall up to 70.0 cm was especially strong at the southern wall as it was based entirely on the alluvial layers of the ditch while the northern wall was founded, at least in its eastern part, on the natural soil. To the south of the house, the ground inclined more strongly to the sector formed by the ditch which, still in the time of Level 35, remained a zone of erosion.

The court area belonging to this house was oriented most probably towards north. An enclosing wall, erected at the same time with the mud walls of the house, as extension of the southern wall towards east, formed a part of the boundary of this complex built directly at the foot of the slope, the angle of the embankment amounting to ca 20°–25°.

At a later date (Phase 2), yet another mud wall was erected nearly in extension to the northern wall. A clearly marked joint as well as differences in colour and the founding on a higher level speak for a later addition. It remains unexplained whether this room was roofed over or not. An occupational level which would have to be placed considerably higher than that of the adjacent room due to the slope could not be determined.

The floor of the excavated house was covered with an altogether 7.0 cm thick layer of ashes. Directly on the mud floor, burnt black, there was found a layer of red ashes, mixed with burnt-red clay, superimposed by layers of greyish blue ashes, mixed partly with reddish brown ashes; in the western third of the interior a thicker layer of whitish brown rotten material.

On the inner surface of the walls larger spaces of daub made of very hard and clayey mud were found, under which the wall had a peculiar black discoloration. It seemed as if this fine plastering contained an admixture of bright brick-red colour because a slightly red colouring could be ascertained even in those places where there were no traces of burning.

South of the house, at 2 IV 10.8/Cc 5.05 in the height of 14.65 m, was found a fragment of a mosaic (Fig. 22) of coloured pebbles pressed into strongly tempered clay, size 18.5 × 16.3 × 4.8 cm. It remains unclear whether it can be regarded as a fragment of floor covering.

Perhaps likewise to assign to this level in 2 IV/Cc are the remains of a mud wall in 2 IV 3.25–4.50/Cc 8.50–9.50, height 14.62–14.84 m.



22 Fragment of mosaic of coloured pebbles. Level 35

3. In the area 2 IV/Be an occupational level of a medium height of 16.70 m could be allocated to Level 35, some floor remains of which could be conserved in the excavated area.

Level 34

1. A hard clay layer with traces of ashes at the height of ca 15.80 m was located as Level 34 in 3 I 3.5–9.5/Ca 7.5–16.5, bounded at the east by a mud wall ca 55.0 cm wide and narrowing slightly upwards (Fig. 23). The course of the wall standing ca 10.0 cm above the level corresponded almost exactly to the north-south direction. In the ground in parts the outlines of the round house of Level 35 were marking themselves. The horseshoe-shaped fireplace of rather larger dimensions, ca 85.0 × 55.0 cm, was founded on the ash-layer of the round house, likewise marked in the ground northwards of the fireplace. The wall of the hearth was composed of reddish burnt clay, the filling, of ashes mixed with sand. Slightly to the southwest of the fireplace, a larger depression was exposed of the diameter 40.0 cm and filled with ashes.

A mud well located at 3 I 11.0/Ca 16.9 most probably belongs to this level. It has been sunk into the ground from the height of ca 15.85 m and ended at ca 10.30 m in aquiferous layers. The excavation of the well yielded in the lower region a large number of pails and pitchers, besides potsherds, fully preserved slipped into the well at the time of its use (POTTERY II.40; 44–47; 49; 55). The well tapering slightly in the

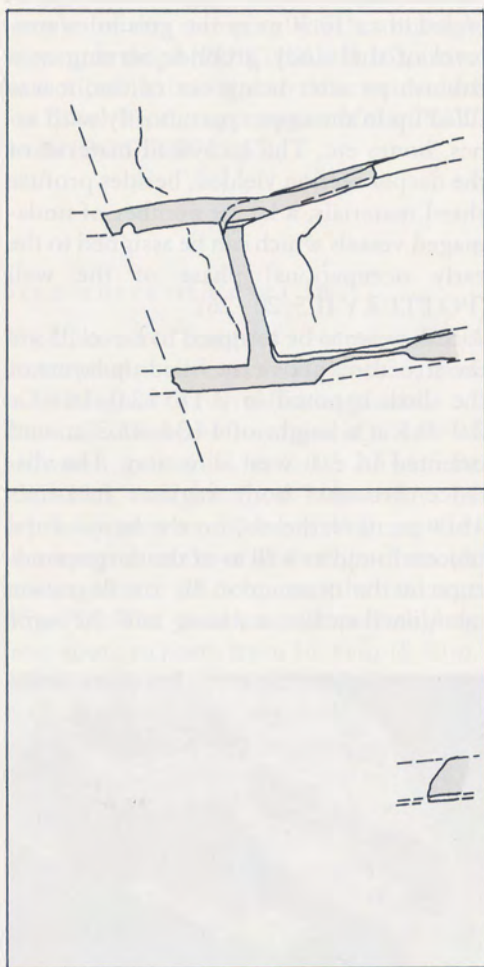

21 Mud structures in 2 IV/Cc, Level 35

lower part had an upper diameter of 1.20 m, widening on the eastern side ovally to 1.80 m caused by demolitions and erosions.

After being out of proper use, the well was used as rubbish pit and filled up with waste material (remains of plants, ashes, sherds, bones etc.). At ca 15.30 m was found a solid intermediate layer, the pit of about 0.55 m depth thus used as a fireplace.

2. In the eastern part of 2 IV/Be was located a mud wall of yellowish-brownish material, 45.0–50.0 cm wide. This wall running in an oval could be followed up in an area of 5.50 by 2.25 m at a height of 16.89–17.28 m. In the inner area, opening towards north-east, was found a layer of yellow sand (PGW material?), height 16.97–17.06 m, in a thickness of 8.0 cm, in which some grooves and post-holes were marked.

In the southern area, connected with the wall, was found a trough of irregular shape whose walls, made of mud, tapered conically upwards (Fig. 24). Its outer width measured 1.25–1.60 m, the inner width 0.50–0.75 m, the length could be followed upto 4.00 m. The trough was halfway overbuilt by a second trough-like structure, height range of the trough about 17.54–16.99 m. The semicircular end of the superstructure ran free over the deeper ground of the trough. Especially this part of the trough, formed by the superstructure, was filled with numerous layers of decomposed residues alternating with loose earth. The bottom of the trough sloped slightly from east to west following the gradient of the ground. In the northeastern corner were found, moreover, the remains of a mud layer.

3. Built upon the outer walls of the structure of Level 35 in the area 2 IV/Cc were found two nearly parallel mud walls of a thickness between 50.0 and 60.0 cm (Fig. 25). The walls, running more or less in eastwest direction, are probably belonging to different court areas. The wall-corners registered in the western part of the field indicate that the court areas have been stretching northwards and southwards respectively. While the walls of Level 35, used as foundations, enclosed a large inner room, it seems as if here the walls enclose a ca 3.0 m wide path of approach from the lower outer area of the swampy ground to the high-placed centre of the habitation.

The differences in height regarding the foundations, 15.30–15.57 m of the northern and 14.70–15.40 m of the southern wall, still indicate, similar to the situation in Level 35, the strong sloping of the level at this period. The western enclosure walls,



23 Mud floor with mud wall and fireplace. Level 34



24 Trough made of stamped mud. Level 34

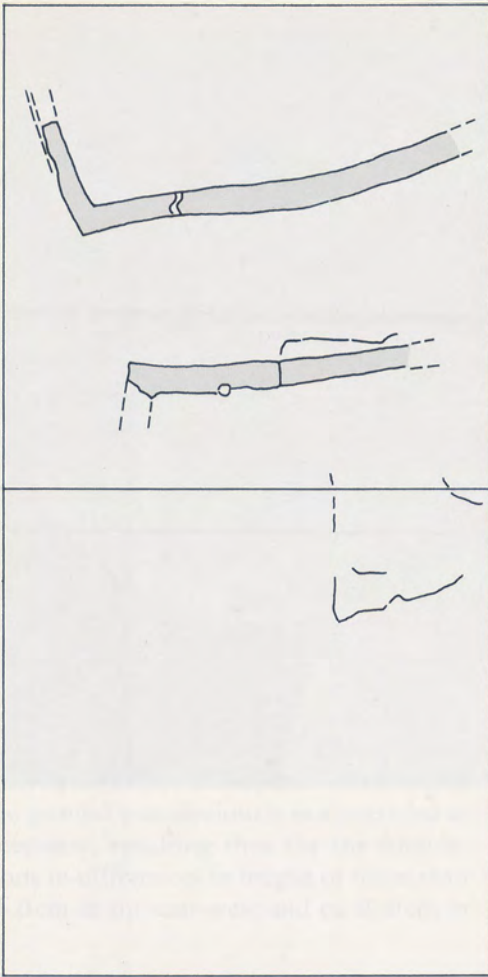

25 Mud walls in 2 IV/Cc. Level 34

set up higher and existing only in parts now, were founded on the alluvial layers of the slope of the former big ditch, still relatively steep. Small remains of a flooring could be registered north of the southern wall, height 14.84–14.92m. In this region were found some spots of daub on the outer side of the wall. Likewise belonging to this Level 34, probably to a somewhat later phase, is a level of hard mud south of the southern mud wall, height 15.30–15.47m.

Level 33

1. Level 33 could be exposed in 3 I 5.0–10.0/Ca 13.0–15.5 as a hard clay floor with blackish-brown and reddish-grey traces of ashes at an average height of 16.15m. As belonging to this level have to be regarded three longish fireplaces at 3 II 4.0–8.5/Ca 18.0–19.5, height 15.88–16.29m (Fig.26). The northern one, ca 60.0 × 25.0cm, had a shallow ashpit of a diameter of 60.0cm. The openings of the other two fireplaces lay within the section wall.

2. In the region 2 IV/Be Level 33 is represented by remains of a hard clay-level in the height of 17.30–17.40m.



26 Fireplaces in Level 33

3. In the 9.00 by 19.00m area of 2 IV/Cc the Level 33 is to be identified with three fragments of mud walls. Two of them, situated at 2 IV 5.5–9.0/Cc 12.5–16.0, founded at the height of ca 15.15m and standing upto 15.50m, are remains of the southwest and northeast corner respectively of two houses oriented SW to NE. The structures, consisting of ca 50.0cm wide mud walls, are laid out parallel to each other, separated by a passageway of 1.50m width.

In the northeastern part of the field, at 2 IV 15.80–18.25/Cc 10.75–14.25, height 15.40–16.20m, a straight piece of mud wall is running southwest-northeast, connected with a small spot of hard clay-floor towards south at 15.87m. The height levels of the northern and southern structures show that the differences in height are still prevailing.

Level 32

1. As structures of Level 32 located in 3 I 3.5–10.5/Ca 6.5–17.5 are to be regarded two mud walls meeting nearly rectangularly, height 16.28–17.00m (Fig.27). The crown of the western wall presented

several regular post-holes (?) as well as irregular depressions, the southern outer part demolished by a pit deepened in from a later level and reaching down to 15.82m. The area enclosed by the two mud walls, opening towards NE, showed two different phases of habitation: a hard clay level at the height of 16.41–16.43m and, second, a level of clay sloping slightly towards north, interspersed with sherds, with spots of whitish rotten material and single smaller spots of ashes, average height 16.63m. To this height belongs a small clay level outside the western wall.

In the southwest corner was deposited a heap of rubbish with vessels, sherds, remains of bones etc.; at the end of the western wall a rubbish dump with lumps of clay similar to clay "bricks"

A deep gully embedded in the hard clay ground at 3 I 11.0–13.5/Ca 14.0–15.0, height 16.77–16.79m, is also to be assigned to this level. Running in the north-south direction, it was filled with charcoal and light grey coarse ashes.

2. As belonging to Level 32 must be regarded a settlement complex at 2 IV/Be, height 17.50–18.10m (lower edge foundation – upper edge wall), which was built of mud, upto 80.0cm wide. Exposed was



27 Mud wall structure. Level 32

the eastern corner of a rectangular building (Fig. 28). The outer walls of dark grey clayey mud running to one another in NW-SE/SW-NE direction surrounded an inner region subdivided by another wall. In the southern inner room, ca 3.10 m wide, excavated in a length of ca 4.00 m, a floor could be exposed at the height of 17.71–17.81 m. Inserted into the floor was a fireplace, size 50.0 × 80.0 cm, the edges reddened by burning. It was filled with whitish grey ashes.

In the room adjoining north, of which just a small part of the southwest corner has been exposed, the height of the floor could be ascertained at 17.79 m.

3. In the area 2 IV/Cc Level 32 was not safely traceable. A number of patches of hard mud level could be exposed, in the north at a height of 16.20–16.40 m, in the southern region at 15.60–16.00 m. As there were no larger structures found along with them, these floor remains could not be assigned to Level 32 with certainty. But a number of terracotta fragments (HUM.TERR. nos. 39; 41) and other finds, among them the two earliest un-inscribed copper coins from Sonkh (COINS, no. 4; 5) support this assignment.

Level 31

1. Remains of structures and habitational areas of Level 31 were found in 3 I 3.0–12.0/Ca 14.5–19.5 in a height of 16.80–16.95 m. Besides the remains of hard clay levels, partly covered with sherds, partly blackened by burning, with shallow gully-like depressions, a wall-corner of lumps of mud-bricks has to be pointed out here specially (Fig. 29). The wall-remains, height 16.67–16.88 m, about 2.00 m long and opening towards NW, consist of lumps of mud of different sizes but rather uniform thickness, ca 5.5 cm. However, it cannot be presumed that they have been prefabricated and dried up in advance but appear to have been set more likely in wet condition.

2. In the area 2 IV/Be the Level 31 is represented by a mud wall construction which is set up directly on the structures of Level 32 (Fig. 30). In contrast to the clayey dark grey material of the preceding level, the walls of this construction consisted of yellowish-brownish, slightly sandy clay. The height of the lower edge of the foundation conforms with that of the crown of the wall of Level 32. The upper edges of the preserved walls of Level 31 range between 18.36 and 18.52 m.

The wall running SW-NE was extended in this time towards south, bordering a con-

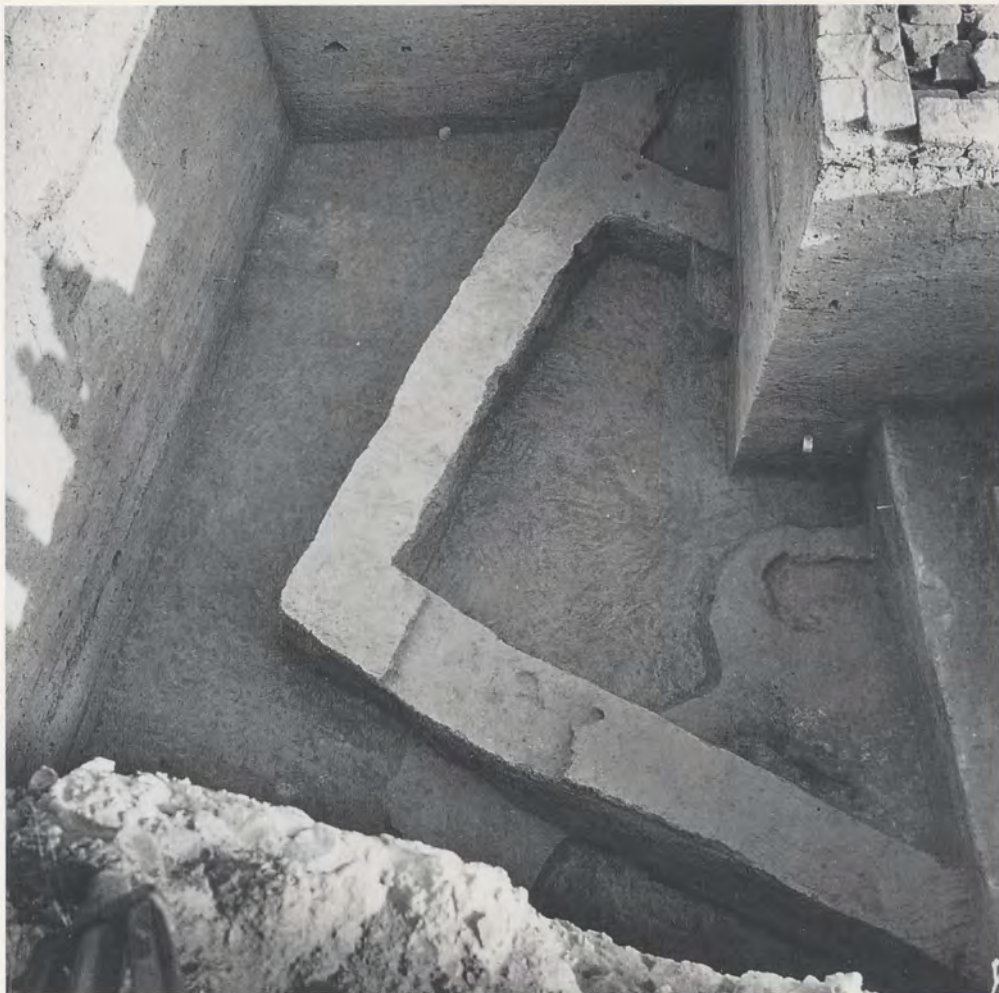

28 Rectangular mud structure in IV/Be. Level 32

necting court area. As no older wall could be used as foundation for this court wall, connected with a joint, a compensating layer of hard, dark grey clayey mud, about 15.0 cm thick, was laid at first to equalize the difference in the height. On it, the court wall was erected corresponding in its material to the walls of the house.

West of the outer wall was located a mud level with greyish white remains of ashes and sherds, height 18.08–18.30, its level corresponding to that of the southern court room, 18.09–18.18 m. Before the western wall lay just one rectangular mud-brick, reddened by burning, the remains of a fireplace probably.

Inside the building two levels of habitation could be ascertained: 1. Height level 17.92–17.97 m, hard mud with rotted remains of plants and ashes; 2. hard mud, 18.10 m in the average. Remains of a mud-plaster of dark grey clayey material were found on the inner side of the southwestern corner of the room.

Of special interest was the furnace located in the northern corner of the room. The wall, ca 50.0 cm wide in the phase of Level

32, had been broadened to ca 1.00 m (Fig. 31). An oval opening, situated on the floor-level, was connected by a ca 60.0 cm long horizontal conduit with a round “chimney”, diameter 25.0 cm, which, integrated into the mud wall, served as flue. A large quantity of ashes, mostly grey but also partly reddish, was found in and by the fire-opening. As far as known this is up to now the only documented occurrence of a



29 Mud-brick structure. Level 31



30 Mud wall structure in 2 IV/Be. Level 31

flue integrated into a mud wall structure of this period.

In 2 IV/Cc the Level 31 can presumably be identified with patches of hard mud level at the height of 16.16–16.39m in the southern area and with two fragments of an obviously very long mud wall in 2 IV 11.50–17.75/Cc 13.00–19.25 and a smaller wall fragment in the north-western corner. The preserved parts of the wall running

from SW towards NE are founded at 16.02–16.21m, standing up to 16.32m. The length of the fragments is 2.75m and 4.80m respectively, the width 50.0–55.0cm. Judging from a patch of floor preserved along the longer fragment, the inner area enclosed by the wall was lying southeast of it. The not preserved south-west corner of the structure lay presumably at the point 2 IV 11.25/Cc 12.30.



31 Detail of furnace in fig. 30



32 Mud floor with post-holes, 3 I/Ca, Level 30

Level 30

1. This habitation level has been exposed in 3 I-II 3.0–11.0/Ca 8.0–18.0 in two hard mud levels with sherds, brick-rubble from fireplaces as well as small pieces of baked clay and traces of ashes. At the western edge of the upper habitation phase, height 17.18–17.25m, lay whitish layers of decomposition.

The middle part of the lower, first habitation phase showed a slightly curved stripe of post-holes nearly in north-south direction of different diameters and depths (Fig. 32). In a pit of about 40.0cm in diameter, exposed at the northern end of this section, were found three bigger pieces of baked bricks, the lowermost appearance of baked bricks in Sonkh at all. In the southern profile a baked brick well-stone of the size 42.0 × 30.0–20.0 × 6.5cm was found and near to it, the remains of another one, at the height of 17.26m.

2. In the region 2 IV/Be the northern corner of a building or of a court enclosure belonging to Level 30 could be exposed (Fig. 33). The westside of this building was erected directly on the court wall of Level 31, not to be separated from that of the older level with regard to the yellowish mud material. The axis of the superstructure is however turned more towards NS and its walls are considerably narrower than those of the older structure, ca 40.0–50.0cm. The north wall, slightly inclined in the upper part towards north, consisted of light grey, more clayey mud in contrast with the west wall. It was placed subsequently against the westwall, the different materials marking themselves clearly at the joint.

The west wall projecting beyond the corner of the structure breaks off at the



33 Corner of a mud wall building in 2 IV/Be, Level 30

very place where in Level 31 the court wall was placed with a joint to the former building. It remains unclear how far a probable wall followed that of the older level.

In the enclosed area the height of the mud-levels covered with traces of ashes lay at 18.45–18.50 m; the outer area, clay ground with ashes and sherds, sloped towards north from 18.71 to 18.41 m.

3. In 2 IV/Cc the remains of Level 30 are restricted to a level of hard mud at the height of 16.46–16.54 m.

D. THE PHASE OF THE MUD-BRICK CONSTRUCTION

If in the preceding Levels the structures were predominantly built in compressed mud, the situation changes abruptly with Level 29 in the whole of the excavation site.

Reaching the ground above Level 30 there were found in all the areas in which structures of the Levels 29 and 28 came to light remains of settlements, farms etc. which had been constructed out of prefabricated mud-bricks. It is true that already in deeper levels smaller parts of structures had been found which were not executed homogeneously in stamped mud, though. But in such cases they were mostly parts of walls

in which the mud was put in some brick-like shape (cp. Level 31). However, uniform sizes as in Levels 29 and 28, waiting to be discussed now, were out of question. Single finds of baked brick fragments or fired bricks of special size (well-stones and others) allow the conclusion that already at the beginning of Level 29 fired bricks were used for special constructions whereas the majority of the houses was constructed of mud-bricks now, probably on economic grounds.

Significant is the fact that the structures of the Levels 29–28, erected in mud-bricks, are not only of partly identical layout but that they anticipated the structures of single buildings as well as the general alignment of the settlement of the Level 27.

The time of the mud-brick constructions in the Sonkh mound is the formative phase of the early “urban” settlement. If the structures of earlier levels did not indicate any primary principles of town-planning this changed now with the time of Level 29. Surprisingly, this coincides with a turning point of the political and cultural history in this part of India because the Levels 29 and 28 are contemporary with the beginning of the Mitra Dynasty of Mathura.

Level 29

1. Of the structures of Level 29 was preserved in 3 I 3.5–10.2/Ca 6.5–17.0 a row of three rooms in the north-south direction (Fig. 34). The southern room could be recorded only to a small extent, the northern room was for the most part demolished by the moat dug in the time of Level 4 so that



34 Remains of a house built in mud-bricks, 3 I/Ca, Level 29

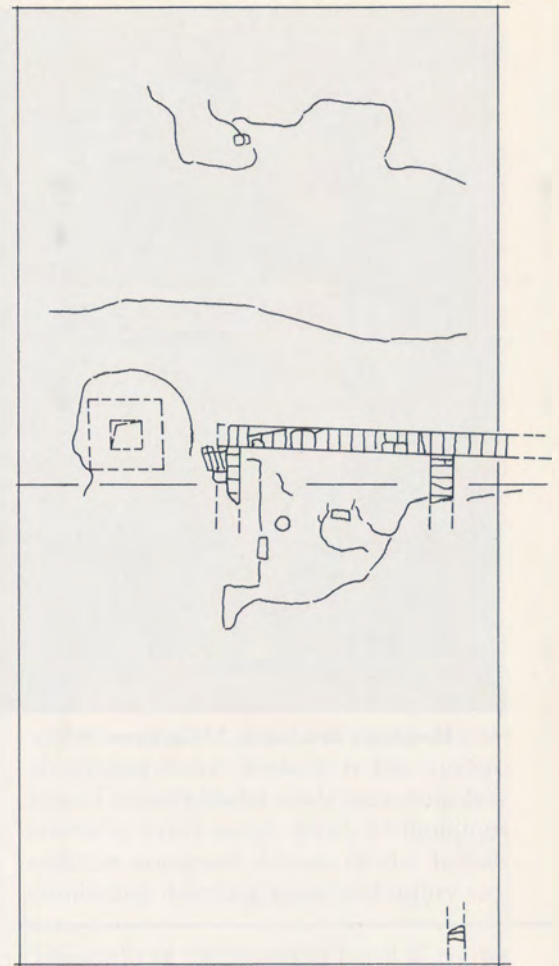

35 Structures of Level 29 in 2 IV/Cc

the extension towards north is lost. External width of the rooms is 3.00–3.15 m, the length of the row 5.75 m, the deepest point of foundation lay at 17.26 m, the highest



36 Mud-brick structure in 3 I/Ca, Level 28

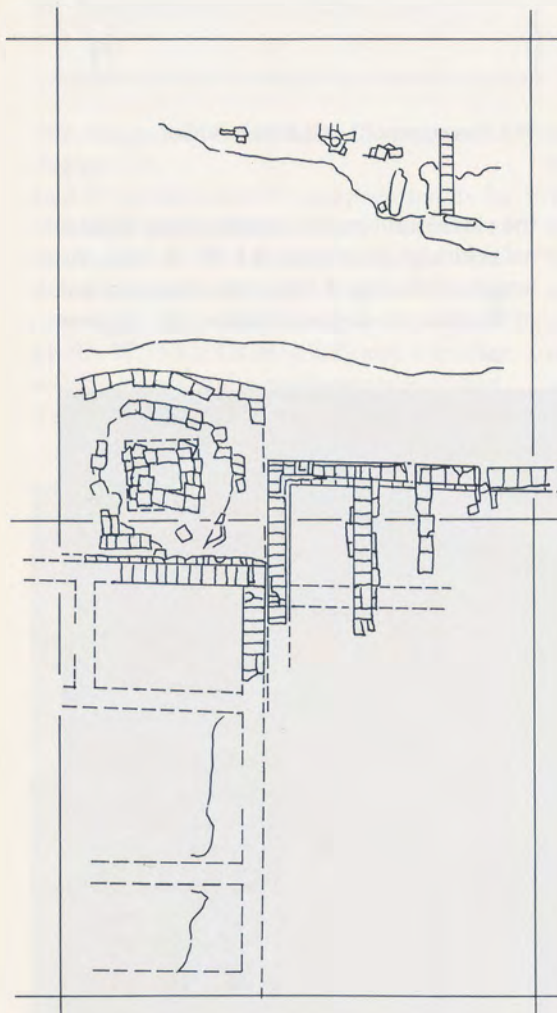

37 Structures of Level 28 in 2 IV/Cc

point of the walls at 17.80 m. The masonry consisted mainly of mud-bricks of a medium size of $43.0 \times 23.0 \times 8.0$ cm.

The southern room proved to be the kitchen, the fireplace with mud wallings full of ashes was found directly between the room wall and the profile of the trench. The middle room, inner dimensions ca 2.20×2.20 m, was used as a storeroom. Evidences of this were the baked brick fragments arranged in a circle of ca 50.0 cm diameter, serving obviously as support for a big storage jar. The ground showed in some places a mortar-like layer of brick-powder on mud as in the outer room. The middle room opened towards the west by a ca 70.0 cm wide door-opening, the threshold strongly worn down, on a court area in a height of 17.52–17.64 m sloping slightly towards north. The surface of the court consisted of mud with spots of mortar of brick-powder, a few sherds and smaller spots of ashes. The height level of the three rooms ranged between 17.62 m in the south and 17.39 m in the north, following the terrain.

2. In the region 2 IV/Be a hard mud level of the height of 19.05–19.13 m is to be assigned to the Level 29. The floor of partly black, partly red fired mud was covered with black and reddish-white ashes and sherds of a large vessel broken into pieces. A large and a small pit from higher levels were cutting through the floor.

The axis of the mud-brick wall, height 19.08–19.57 m, running in the WE direction corresponded in its course nearly to that of the masonry of 3 I/Ca and is comparable also in the size of the bricks to that of the row of rooms exposed there.

3. The floor of Level 29 in the area 2 IV/Cc was divided in a northern and a southern part (Fig. 35). The northern patch has been exposed at a height of 16.65–16.86 m, the southern part of the floor extended at an average height of 16.95 m. Also preserved were mud-brick walls of the north-west corner of a house forming the remains of two rooms. The structure consisted of a 5.75 m long northern wall projecting from the eastern profile in nearly east-west direction at 2 IV 10.50–11.00, ending in 2 IV 10.75–11.25 where scanty remains of the western outer wall were joining rectangularly. A further fragment of a wall met the long northern one at 2 IV 10.60/Cc 8.75–9.25 thus forming a western room measuring 4.00 m on its preserved northern side and indicating another room to the east of which only the north-west corner remained. The walls were founded at a sloping height of 16.63–16.82 m, standing up to 17.02 m. The bricks measured $43.0 \times 23.0 \times 8.0$ cm. The whole structure resembled the one in 3 I/Ca.

To the west of the house a brick-built well of Level 28 was cutting the ground.

Level 28

1. The structures of Level 28, exposed in 3 I 2.0–10.0/Ca 10.0–17.0, closely followed in direction and layout those of the rooms of Level 29. The walls of the older house were used as foundation, however, between the mud-brick courses of the two levels a thin mud layer could be noticed. Slight differences in the measurement of the structures were conditioned by the different sizes of the mud-bricks used: for the western wall mainly such of $45.0 \times 23.0 \times 6.0$ cm, for the eastern one shorter but otherwise identical bricks of $35.0 \times 23.0 \times 6.0$ cm (Fig. 36).

The external width of the rooms was about 3.00 m. A hard mud-floor with whitish remains of rotten material was found in the outer room. To the west was exposed a court ground with the remains of a mud-brick-flooring and parts of fired bricks at a height of 17.95–18.00 m. As with the comparable structure in Level 29 the extension towards north is lost due to the large moat dug in the time of Level 4.

The remains of the mud-brick house in the area 2 V 18.5–3 I 3.0/Cb 4.5–9.5, outer di-

mensions ca 3.05 m, proved to be oriented parallel to the above structure. The walls of the construction in the north, for the most part demolished by the just mentioned moat of Level 4, were of unusual thickness, 60.0 cm on an average, and were built of mud-bricks of very different sizes. At the south-east corner were added two short remains of walls. The wall in extension to the southern wall consisted of mud-bricks of the size 42.0 × 23.0 × 6.0 cm.

2. In the area 2 IV/Be was found a mud-brick wall of Level 28, made of quite differing sizes of bricks, width ca 40.0 cm, height at 19.20–19.34 m, in connection with a level of yellow mud, 19.20–19.29 m. The axis of the wall ran parallel to those of the structures of this level recorded above. In the north-eastern corner a pit was sunk about 45.0 cm into the soil, full of ashes and sherds, diameter ca 1.10 m.

3. Level 28, in the area 2 IV 6.00–18.50/Cc 0.50–10.50, is to be regarded as a kind of direct scheme for the later Level 27. The ca 7.00 m wide access road from the east was now clearly marked, height level between 17.12 and 17.00 m, the middle of the road eroded by the flow of water. On this road, one of the two Gomitra copper coins was found (COINS, no. 55).

Also the southern border of the main road was now completely developed, consisting of the remains of two large buildings (Fig. 37). The eastern structure, built in mud-bricks, seems to have formed the northern section of a larger block, unfortunately destroyed by the moat of Level 4. A large gully, covered with burnt bricks, drained unto the street level.

The western structure in burnt bricks, set back to the south about 3.20 m, in the earlier phase only partly preserved, could be reconstructed as the eastern row of rooms of a larger block extending into the unexcavated area. The later phase showed remains of, at least, three rooms, extending to about 8.50 m in south-north direction, height of the structures unearthed between 17.00 and 17.80 m.

The most astonishing feature of Level 28 was, however, a large rectangular, nearly square public well situated in the corner formed by the two blocks opening to the north, to the road, erected on a kind of platform, about 4.00 by 4.00 m, enclosed by a partly stepped brick socle. Height of the platform and the partly preserved brick flooring at about 17.60 m on an average.

The well, upper level at about 17.80 m, was built in burnt bricks of the size 40.0–41.0 × 26.5–27.0 × 7.0 cm, inside dimensions ca 0.70 × 0.65 m. The ground-water level was reached at a height of

10.65 m (02/1974), the lower portions of the wall still reaching down, below 10.15 m. In a later phase, the upper part of the well shaft was repaired or heightened.

Remains of a small mud-brick wall, set against the northern wall of the adjoining block may indicate the construction of a lean-to shelter as a protection of the well.

E. THE BEGINNING OF THE BAKED BRICK CONSTRUCTION IN THE LEVELS OF THE MITRA PERIOD

With Level 27 we enter the phase of baked brick constructions in the mound of Sonkh. Although mud-bricks were still in use, the majority of buildings were now erected in baked bricks. Mud-bricks were reserved for minor structures and perhaps for houses of the less wealthy. From the viewpoint of town planning the Levels 27 to 25, including may be the baked brick parts of Level 28 in 2 IV/Cc, are forming one homogeneous phase, not only based on corresponding architectural features but also proven by the related finds.

Level 27

The Level 27 is not only the oldest horizon built mainly of baked bricks but, at the same time, a model of well-contrived and up to the smallest detail well-planned constructional units. Striking is the conception of broad parallel roads providing easy access to every single block of buildings and the congenial layout of the houses combining dwelling space and utility sector.

The outfit of the houses in Level 27 shows a comfort never attained again in the later levels of Sonkh. There are, for instance, the public as well as private ring-wells made of terracotta elements always situated in the south-west of the houses, indicating hereby the continuance of traditional rules. The arrangement of the houses, consisting mostly of two or three rooms, covered with roof-tiles, followed also distinct rules but offered at the same time always new and convincing solutions. On the one hand it was possible to group several houses one after the other, parallel to the road, in order to attain a continuous change of dwelling space and court (Block B), or to arrange them along the sides of an inner court, therewith anticipating the coherent constructional unit of later times (Block D).

Structures of Level 27 came to light in the extensively excavated area in 2 V/3 I-Ca/Cc as well as in the plots 2 IV/Be and 2 IV/Cc. The correspondance in the layout with the remaining parts of Level 28 in 2 IV/Cc leads to the conclusion that Level 27 in part perhaps continued structures of Level 28, but in its improved technology and its development created a model of settlement which represents an architectural and social peak.

The floor-level of the occupied area of Level 27 slopes north from 2 IV/Be towards 3 I/Ca from 19.60 m down to



18.00m, and towards 2 IV/Cc in the east to 17.50m. The walls unearthed in this region were rising partly to a height of 0.50m above the floor level.

The alignment of the housing area orientates itself by the main road no. 1 running approximately in west-east direction. This 3.50m wide road slopes from 18.30m in the west to 17.57m in the region 2 V/Ca-Cc and is crossed in Cc by the again 3.50m wide road no. 2.

The west-east road no. 1 continues in 2 IV/Cc widening now to 7.00m, thus indicating that this stretch most probably was part of the approach road from the east, as recognizable already in the construction of Level 28. The public well of Level 28 in 2 IV/Cc, perhaps still in use in the first time of Level 27, sufficiently adds to the assumption that this area was some sort of a public meeting place. Whether or to what extent the open space

around the Apsidal Temple no. 1 was already existing or whether one has to expect here a crossing of roads could not be ascertained.

In the excavated area of Level 27 altogether nine residential blocks have been located. North of road no. 1 are situated Blocks A-D occupying a depth of ca 15.00m. They are bounded in the north by road no. 4. South of the road no. 1 remains of mud-brick walls have been found, per-



38 Level 27: Blocks A and B from south-east

haps of a Block G. To the east of road no. 2 follow the Blocks E and F while to the south of the road in 2 IV/Cc remains of the Block H came to light. An indication of a ninth Block I is given in scanty remnants of structures in 2 IV/Be.

Block A

As far as excavated the Block A consisted of seven rooms arranged along a rectangular inner court extending 5.0×9.5 m south-north. The access to the block leads from road 1 through a narrow, 0.8 – 1.0 m wide lane in to the court. The complex of rooms seems to have had connection towards west where the excavation area ends. In the north-east corner opens another path of access around the corner of Block B, perhaps meeting road no. 4 (Fig. 38). The most remarkable part of Block A is the hall in the north measuring 2.50×6.50 m in the clear. It opens towards the south and is furnished with a carefully laid baked brick flooring. The floor consisted of baked bricks of the size $43.0 \times 30.0 \times 7.0$ cm and $42.0 \times 31.0 \times 7.5$ cm, laid in

mortar made of brick fines. To the right and left of a brick pillar there is an opening each 1.90 m wide leading to the inner court. On the right side of the hall was found a sole of hard clay, obviously the remains of a former bench. The extensive paved area of the court necessitated the laying out of a drainage channel. Most probably the channel was open in the courtyard; in the hall itself, however, which it crossed slightly diagonally, it was ingeniously embedded in the baked brick pavement and covered with bricks. It drained towards the north through a breach in the northern wall of the hall. Next to the channel immediately behind the back wall stood a large soakage jar embedded in the earth and covered with brick. In this outer area remnants of another structure and of a paved floor are the outermost witnesses of this level at the verge of the large moat dug in from Level 4.

In the west of the court area is a group of three rooms (2–4) nearly equal in size measuring $2.2 \times 2.3/2.4$ m. They are separated from the hall and the southern chambers by a sort of lane each, paved and approx-

imately 0.90 – 0.95 m wide, which lead to the court from the west. The northernmost room has its approach from the inner court, the other two are to be entered from the western side. In the south the block is completed by the group of store-rooms (5–7) of different size (3.25×2.30 and 2.60×2.30 m).

The court is bounded in the east by a long closed wall without any door-opening being the partition wall between Block A and B. Immediately in front of this wall were found heaps of roof-tiles on the floor of the court.

The sizes of the bricks used in the walls of Block A measured

$37.0 \times 24.0 \times 6.5$ cm
 $38.0 \times 23.0 \times 7.0$ cm
 $43.0 \times 26.0 \times 7.0$ cm
 $43.0 \times 29.0 \times 7.0$ cm
 $44.0 \times 29.0 \times 6.5$ – 7.0 cm
 $44.0 \times 30.0 \times 7.0$ cm.

Block B

Block B measures ca $7.20 \times 15.25/16.00$ m and consists of seven rooms which are

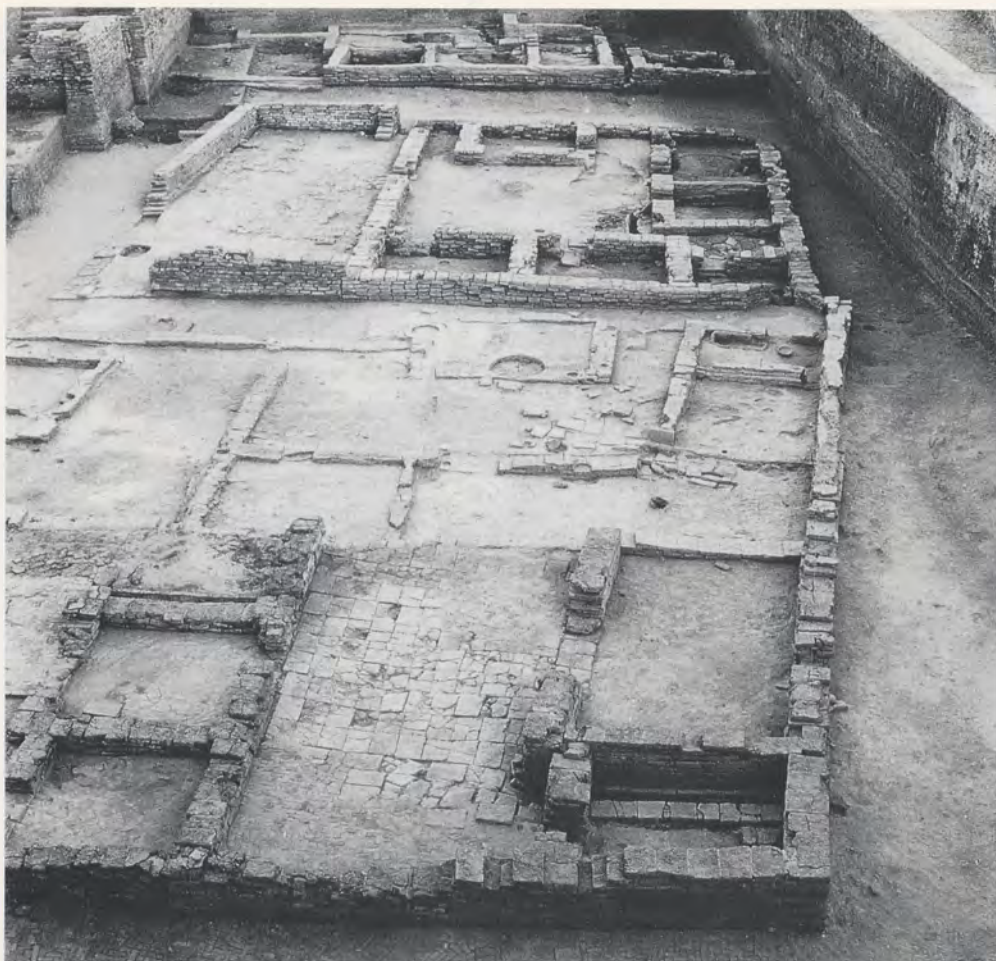

39 Level 27: Blocks B-F from west



40 Level 27: Ring-well in Block D

grouped along two inner courts. While the access to Block A leads through a narrow lane, Block B is entered through room 10 which serves as a passage on to the paved first court (Fig. 39). From here one reaches room 9 on the road side and the central group of rooms 4 to 6 north of the court. Room 5 presumably permitted the access to the northern court which is flanked by two rooms of equal size (2, 3) arranged along the closed western wall. Room 6, obviously open to the upper court, is provided with a short drain.

While Block A, especially its hall, had been erected of bricks of averagely $43.0 \times 29.0 \times 7.0$ cm, Block B was, strangely enough, erected with bricks measuring $37.0/38.0 \times 24.0 \times 7.0$ cm. Both sizes seem to have been used side by side but nearly never mixed. In this connection one should not forget the additional variety as e.g. in Block D with its ca $48.0 \times 24.0 \times 7.0$ cm bricks.

Block C

In the space following east of Block B, denoted here as Block C and measuring ca 9.2×15.5 m, only scanty remains of one room and a long wall are preserved which do not permit a reconstruction of the layout. Only in a later phase of use some structures in mud-brick were found, but of minor appearance.

Block D

Block D measures ca $11.75 \times 15.0/13.75$ m and is surrounded on three sides by the roads no. 1, 2 and 4.

While Block A and B could be entered through a narrow lane or an entrance room, the corner-Block D surprises by a new conception. One enters the house in the north through an 11.00 m long and 4.50/5.30 m wide forecourt which follows in the north the alignment of road no. 4 but is bounded in the south by the walls of the residential quarter arranged rectangularly with the roads 2 and 1. At both sides of the paved middle part of the forecourt a few remains of former structures, presumably sheds, are preserved.

By a door, the door hinge stone still in situ, one enters the inner court (2) enclosed by houses with separate access to each room grouped to the west, south and east. This nearly square complex measures 11.75×9.25 m and consists of seven rooms of approximately equal size, i.e. 5.0–5.5 sqm in the clear, with the exception of room 5. This smaller south-west corner room, 1.5×1.9 m, contains a ring-well (Fig. 40).



41 Level 27: Roof-tiles and Pinnacles in Block D

In a corner stood a water jar. The well consists of 36 terracotta rings one resting on top of the other but merging into one another now. The rings are ca 19.5 cm high. The outer diameter of the well is 82.0 cm, the inner 72.0 cm, its depth 6.30 m. Unlike the terracotta ring-well in Level 26 (3 I/Ca), which is situated in a public well house, this certainly private well served for the water supply of Block D alone.

As the floor of this complex slightly slopes towards south, a gully was built in the ante-room to avoid a contamination of the well by rain or waste water pouring in. From this point of view it is interesting to see that the front wall of the well room is clearly set back, most probably to get a larger roof projection against rain and heat.

In several rooms have been found remains of the collapsed roof construction consisting of roof-tiles, ridge tiles and pinnacles (Fig. 41).

Contrary to the other blocks discussed so far this Block D has been erected completely of baked bricks of a relatively uniform longish type of the sizes

- $48.0 \times 23.5 \times 7.0$ cm
- $48.0 \times 24.0 \times 6.5-7.0$ cm
- $48.0 \times 24.5 \times 6.5-7.0$ cm
- $49.0 \times 24.0 \times 6.5$ cm
- $50.0 \times 23.0 \times 7.0$ cm.

It might be an indication that this complex has been built according to a clear plan in one extreme effort and in a short time.

In the inner court, just before room 6, was found a large storage jar embedded in the ground. In addition, there have been lo-

ated traces of fireplaces in both the courts of the complex. The middle room of the southern row contained a fireplace built of bricks, identifying this room as the kitchen.

Blocks E and F/I/H

To the east of road no. 2, i.e. on the eastern verge of the excavated area, are situated the unearched parts of the Blocks E and F. The Block E shows, as far as recognizable, a similar layout of rooms as Block D. Here again a ring-well has been built in the southwest corner room for the private water supply. But contrary to the well in D terracotta elements were used only in the upper part for ca 2.00 m, the lower part being executed as a tapering mud-well only. This well was in use up to the latest phase of Level 27 and even in the beginning of Level 26, when the well shaft, narrowing upwards, was raised by new layers of baked bricks, according to the rising height of the floor level.

To the south follows the more modest looking construction of Block F. One should however not exclude the possibility that this complex was laid out reaching further east extending into the unexcavated area. The drainage took place by a 0.50 m wide gully leading on to road level, being connected with the drainage of Block E running in front of the well room. The outer walls of the rooms adjacent to the gully are protected against decay by roof-tiles placed upright into the drain.



To the south of the here 7.00m wide main road (no. 3) have been found remains of walls following the ground-plan of Level 28. The scanty remains of this Block I, unfortunately, do not allow a reconstruction of the layout of rooms. Preserved is, however, the place of the public well of Level 28. This well was most probably still in use in the beginning of Level 27 before it became more and more usual to erect private wells in the houses, as practised in Block D and F.

Block G; south of road no. 1, is traceable by scanty remains of walls only along the street, the arrangement of rooms in this complex can not be reconstructed.

Block H, in 2 IV/Be, could be unearthed in a small section only showing remains of three rooms which do not betray the layout of this Block. But it is remarkable that here the highest point of Level 27 with a height of 19.60m could be registered.

Levels 26 and 25

At the end of Level 27 most of the described blocks of houses were overbuilt with mud-brick structures. Whether external circumstances or influences were responsible for the striking change in the building method is not recognizable. Such a step backward most probably coincided with a cultural, economical and political decline in the time after Sūryamitra. The new structures complied however closely with the old layout of houses. Only with



42 Level 26: Block E from south



43 Level 26: Drain between Blocks E and F



44 Level 26: Buildings north of Blocks B and C

the coming of Levels 26 and 25 occur alterations which bring about some deviations from the constructional rules followed in Level 27.

Level 26

The overall planning of Level 26 still follows the course of the roads of Level 27, esp. that of road 1 and 2, and retains the same distribution of blocks. The layout of rooms within these blocks, however, is occasionally different now.

The buildings of Level 26 are, as already mentioned, mostly erected of mud-bricks complying with the size of the baked bricks, i.e. $42.0 \times 28.0 \times 7.0$ cm. Houses of baked bricks were found only sporadically, built presumably of reused bricks, with the exception of the northernmost structures in 3 I/Ca-Cb.

The niveau of Level 26 slopes from west towards east from ca 18.90 to 18.00 m, towards north to 18.50 m.

Of the former Block A only four rooms came to light in the southern part along road no. 1. Of these, room 3 can probably be identified as a kitchen because of the two fireplaces, one larger and one smaller one. More of the old ground-plan is preserved in Block B separated from Block A now by a 1.20 m wide lane. The southern row of rooms along road no. 1 with its entrance room is now replaced by a court area, but the houses of the rooms 2–3 and 4–6 are using as foundations the walls of Level 27. Block C gives, as already noticed in Level 27, the impression of an area used only for annexed buildings (store or toolrooms?). Noteworthy is especially the large building situated at the road no. 1, measuring 3.50×6.50 m. Remarkable are, in addition, a number of larger utensils of sandstone found in the middle of the block.

The remains of walls in Block D show for the most part the same layout as those in Level 27, the only exception being the long baked brick room on the northern side of the block, where formerly a large forecourt was extending. The 4.00×12.00 m long structure erected here reminds one of the public hall in Block A of Level 27. Like there, the room is to be entered through two openings, 1.75 m and 2.25 m wide, extending to the right and left of a middle brick pillar. In the western corner of this room an unusually large fireplace was sunk in to the mud floor.

In the Blocks E and F the ground-plan of Level 27 remains almost unchanged (Fig. 42). The ring-well in room 4 was still in use but had to be raised by new layers of baked bricks corresponding to the higher

ground level. In Block E this level had increased so much (18.40–18.50 m) that the gully draining onto the street level (18.00–18.10 m) had to be bordered with baked bricks. In the gap (0.60 m) between E and F the drain was, in addition, lined with baked bricks to protect the mud-brick walls of the houses against soaking (Fig. 43). In the court of Block E a large storage jar has been found embedded in the mud floor.

To the south of road no. 1 a long mud-brick front of the former Block G and the north-east corner of a neighbouring block to the east are the only remains of structures, certainly not enough to make more of it.

Entirely differing from the layout of Level 27 are the two baked brick buildings erected in 3 I/Ca-Cb, i.e. north of the Blocks B and C (Fig. 44).

The room to the west, inside dimensions ca 1.80×2.70 m, was presumably constructed with a room following north and contains a ring-well 7.70 m deep, consisting of 37 terracotta rings, diameter 87.0/79.0 cm, height 21.0–22.0 cm. The lowermost terracotta rings were still reaching the ground water-level when excavated. The floor of the room around the well is carefully circularly paved with baked bricks, partly wedge-shaped. The room was to be entered from the east.

The eastern house, ca 2.70×2.50 m in the clear, might be identified as a kitchen. To the southern side of a fireplace with several openings was found a sort of working table, erected of baked bricks, under which a jar was standing. This room had its entrance in the north (Fig. 45).

The two houses are separated by a lane ca 1.10–1.30 m wide.

The position of the well-room corresponds to that of the comparable rooms in the south-west corner of the Blocks D and E in Level 27. But here the rooms seem to have been planned as separate buildings, as e.g. the kitchen, and probably also the well-room with an adjacent chamber in the north.

With regard to the urban development it is quite possible that these buildings, especially the well, have been public property and therefore in common use, all the more so, as except in Block E, no other well was found anywhere else in this level.

The bricks used for the houses measured

$39.0 \times 28.0 \times 7.0$ cm

$40.0 \times 29.0 \times 6.5$ cm

$42.0 \times 27.0 \times 7.0$ cm

$42.0 \times 28.0 \times 6.5$ cm.

Level 25

The structural remains of Level 25 do not preserve much of the layout of Level 27 anymore. Although road no. 1 is still a sort of axis for the settlement, the constructional units in the blocks of buildings, as already in Level 26, are now abandoned. Block B is the only unit showing some relation to the the older levels, whereas the rest of the excavated built-up area consists more or less of separate houses.

As in Level 26 the structures are mainly built of mud-bricks. It is suggestive that the few baked brick buildings are erected of brickbats mostly, supporting the hypothesis that the baked brick structures in these Levels 26 and 25 are constructed of reused materials exclusively.

The room bordering on road 1 in the former Block A is still used as kitchen. The ad-



45 Level 26: Room with ring-well



adjacent walls do not help to reconstruct its surroundings. The structures to the north (3 I/Ca) most probably are separate units not incorporated in a block, just as no connection is recognizable anymore between the Blocks A and B as in Level 27.

In the area of Block B the rooms 1 to 3 laid out in north-south direction, and 4 to 6 in west-east resume the old position but are rather poorly built. Conspicuous is the kit-

chen with its three fireplaces at the eastern wall. Within the area of the former Blocks C and D no greater structural units were recognizable. The same is valid for the area of the Blocks E/F/G, where poorly built separate structures have replaced the former buildings.

The, probable, public well north of Block B, built in Level 26, may still have been in use in Level 25. The structural remains east

of the well and north of Block D are out of any context.

The structural situation of Level 25 leads thus to the conclusion that towards the close of the Mitra period the building activity came temporarily to an end. The people seem to have been content to live in houses left over from better times, not showing any impetus to continue former urban activities.

The Roof Construction in Levels 27 to 25

References to finds of roof-tiles and pinnacles can be found already in the beginning of this century in diverse publications on excavations performed in Northern India. Especially noteworthy in this respect is the report of T. Bloch (1903/04) about his work in Basarh/Vaisali and the comments of J. Marshall (1911/12) in connection with his excavations at Bhita.

Bloch unfortunately does not date the relevant structures when he writes:

“The roof (of the houses) was formed by tiles of which plenty were found among the débris. They differ from those now used in Bihar. There was a rim on each side near the edge, one above and one below, by which the bricks were joint together, and a hole near the top held the peg by which the tile was fastened to the bamboo frame of the roof... The top of the roof must have been crowned by pinnacles of which one

has been restored in the woodcut of Fig. 6”. His description of the roof-tiles found in Basarh is very much in line with the remarks of Marshall who dates the roof-tiles found in Bhita into the Maurya period:

“This Mauryan building must have fallen into almost complete ruin before the structures of the succeeding stratum above were erected, for the débris beneath the floor consisted largely of roof tiles, semipetrified wooden beams, and bricks from the walls of the Mauryan dwelling. The roof tiles were roughly on one side, plain on the other, and provided at the edges with flanges, which overlapped one another, so that there was no need of separate ridge tiles, such as were used at a later date to protect the interstices between them”.

This dating and the limitation of the tiles’ use into this period is contradicted by the fact that on the one hand the figures are not exactly allotted in the description and, on the other, pinnacles and one fragment of a

roof-tile which is designated as “similar ... in all respects” is dated into the Kuṣāṇa resp. Gupta time.

In comparison with the roof tiles excavated by Marshall having the size of $10\frac{1}{4}'' \times 6\frac{1}{2}''$ resp. $11'' \times 6''$ the specimens found in Sonkh, measuring $32.0-35.0 \times 20.0-24.5$ cm, are considerably larger.

The stratigraphic situation in the mound of Sonkh fortunately provides the possibility to date the occurrence of the tiles in this place more exactly. Conspicuous is the coincidence between the concentrated occurrence of roof-tiles and the beginning of the period of the baked brick constructions in a large scale in Level 27. For the levels below Level 27 no roof-tiles have been traced.

The distribution of the findspots of tiles betrays no doubt a connection between the materials used for the structures and their roofs. Larger accumulations of tiles and fragments of such have exclusively been located in the areas of baked brick buildings, especially and extensively in the Blocks A, B and D of Level 27. Similarly, roof-tiles found in the Levels 26 and 25 were connected with baked brick structures only. For the roofing of mud-brick buildings other materials like reed, grass etc., seem to have been used. Occasionally, roof-tiles have been misused for other purposes, as e.g. for the protection of walls against soaking as in the gully gap between Blocks E and F.

The construction of roofs, mostly crowned with pinnacles, was quite similar to that even nowadays in Northern India (Güntert 1973: pp. 295 ff.), with the exception that the use of interlocking roofing tiles, as in the time of Levels 27 to 25, seems to be superior to nowadays’ covering with semi-cylindrical tiles.

The subdivision of the building complexes in different rows of rooms and larger units (hall in Block A, Level 27) had not only functional but also structural reasons – structural mainly because of the material intended to be used for the roofing.

Level 27 is the first and earliest level in which roof-tiles were used as roofing material. As the roofing of houses joining each other in a right angle was, unlike flat-roofed buildings, apparently difficult to cope with, rectangular groups of rooms were built and attention was given to an adequate space between them. It explains why there were no especially shaped tiles found for the construction of a roof valley. Judging from the angle of the ridge tiles the houses were furnished with gable roofs showing an inclination of about 30 degrees. The structural gaps between the

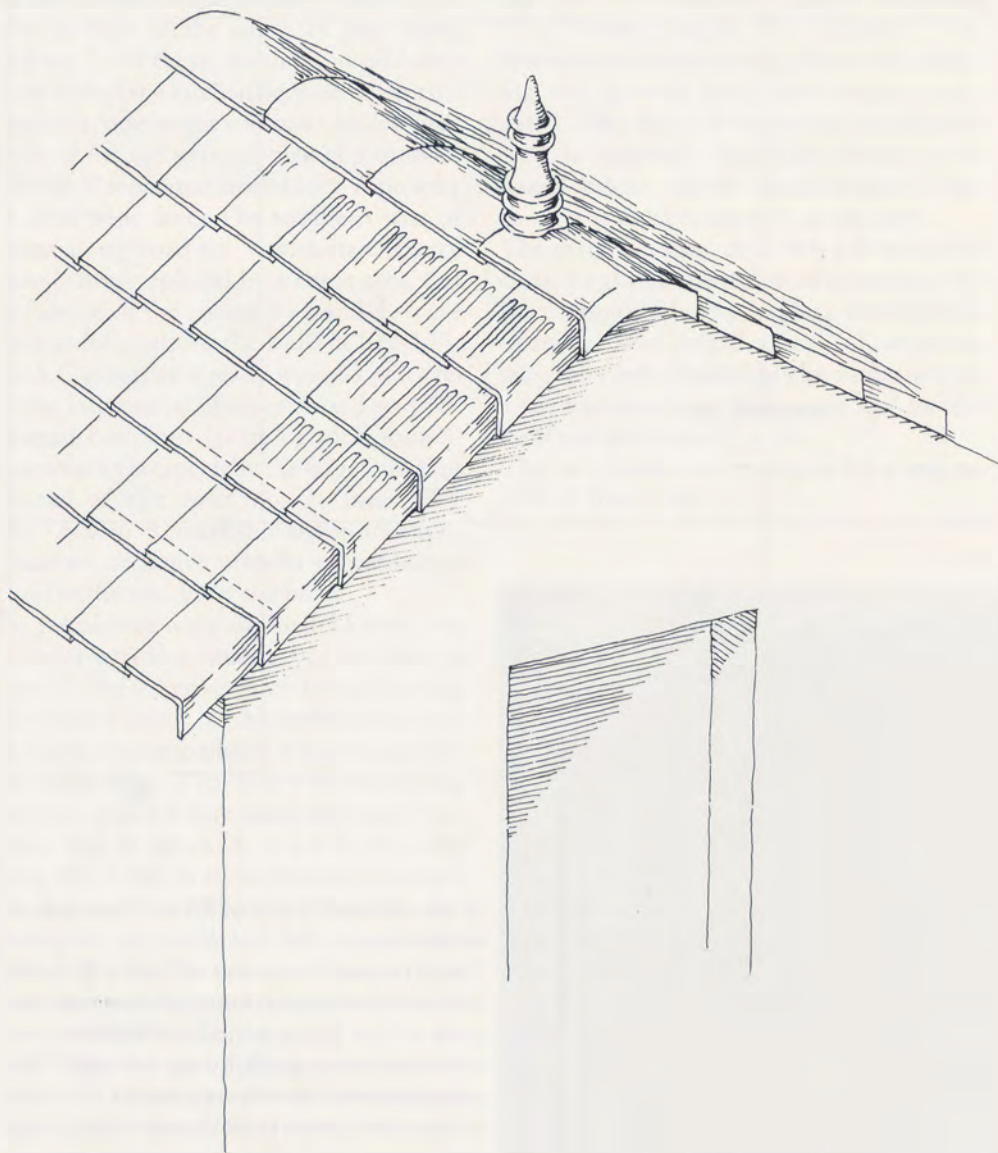

houses or groups of rooms of averagely 0.90m provided sufficient space for the projection of the slanting roof, serving at the same time as protection against rain and heat.

The impressions preserved on lumps of clay of the roof structures found in the debris allow to draw rather helpful conclusions on the technique of the construction of these roofs and the materials used (see Some Structural Objects, nos. 2–5).

As rafter served beams or trunks of ca 15.0cm diameter. Corresponding to the size of the roof-tiles, i.e. in a distance of 32.0–33.0cm, the rafter was covered two by two with bamboo or other thinner sticks (diameter between 2.5 and 5.0 cm) as lathing, the differences in size levelled out by partly thick layers of clay mixed with chaff. Additionally, the crossing sticks were most probably bound together with ropes at the junctions. The use of couples of bamboo sticks might have served for a larger bearing for the roof-tiles.

Upon the lathing levelled in the described way the roof-tiles were laid in a now thinner bed of clay. The lateral overlapping was determined by the grooves of the tiles. As it can be concluded from the clay impressions, the vertical overlapping may have amounted to ca 5.0–6.0cm and was obviously taken into account for the design of the tiles, because they were left plain in the upper part but otherwise decorated by finger grooves or wavy lines on the display side. Other décor, as e.g. lotus rosettes, occurred rarely (see Some Structural Objects, nos. 13–15). In a few cases the tiles were bevelled on the upper side to get a better bearing. The holes near the upper edge in quite a number of roof-tiles indicate that a number of tiles was not only pressed into the clay but, in order to obtain more structural strength, connected with the lathing by wooden pegs or ropes.

The ridges were covered with semicircular ridge tiles (see Some Struct. Obj., nos. 16–17). The gable side was bordered by specially shaped gable tiles showing eaves of ca 8.0cm (see Some Struct. Obj., nos. 18–20).

The roofs were crowned, at least on the gable sides (Fig. 46), with comparatively tall pinnacles (see Some Struct. Obj., nos. 22–24; cp. also Votive Tanks, no. 13).

Impressions in the lumps of clay preserved from the roof constructions permit to conclude that the inner side of the roof, at least occasionally, was lined with split bamboo cane or similar material.

F. THE KṢATRAPA LEVELS

Level 24

While the situation of Level 25 led us to the conclusion that towards the close of the Mitra period the regular building activities had nearly come to an end, Level 24 presents the quite different sight of a newly revived building activity freed from the town planning ideas of the former levels with the exception of small buildings erected on older foundations. The general alignment of the houses however follows the traditional direction.

It is true, Level 24 does not show the built-up areas and the strict partition in blocks bordered by roads as in Level 27, but large building complexes like the Block E in 2 V/Ca-Cb speak of a new time of wealth and prosperity in Sonkh.

The floor level of the area in Level 24 ranges between 19.80m in the west, 20.00m in the north, and 19.20m in the east.

Houses A–D

In 2 V-3 I/Ca the structures of four separate building complexes have been unearthed.

House A, erected of brickbats, consists of two rooms, measuring altogether

3.10 × 6.25m. Towards east lies a courtyard with remnants of a brick pavement.

The houses B and C could be located only by a few remaining walls, those of house B built of brickbats and those of house C mostly of mud-bricks. The southern wall of B and the northern one of C follow the borderline of the old Blocks A and G in Levels 27–25. The distance between the two buildings corresponds still to the width of the road no. 1.

House D, erected of mud-bricks, is similarly aligned as Block B in Level 26. While the fragmentary spots of the courtyard show a baked brick pavement, the floor within the rooms consists of mud-bricks placed upright. In the floor layer of room 2 could be traced the impression of a large storage or water jar (?), and in the south-east corner of room 3 a fireplace built of upright placed baked bricks. To the north of house D was situated a most probably circular floor space, presumably a threshing floor.

Block E

The main construction in the excavated area of Level 24 is the large Block E. With its outer dimensions 14.20 × 14.40m, i.e. ca 205 sqm, it is the largest coherent block hitherto excavated in Sonkh (Fig. 47). Its



47 Level 24: Block E from south-east



twelve rooms enclose a nearly square, ca 7.5×7.6 m wide inner court.

Built completely of baked bricks, mainly $42.0 \times 26.0 \times 6.0$ cm large, the building gives an impression of wealth and prosperity after a time of decline in the building activity (Fig. 48).

The western row of rooms, depth ca 3.00 m like the northern row, consists of four rooms of different size, the northern row

of perhaps only two rooms. The structures on the southern side have stronger outer walls and measure, like that on the eastern side, 3.50 m in depth.

Room 12, 6, and the inner court show remains of a carefully paved baked brick floor. In this court were placed at least four large jars. Two were found in the south-west corner, embedded ca 0.45 m and enclosed by a brickbat base. As in all levels

the south-west corner of the houses was reserved for the water rooms (well, jars), these vessels most probably have served as water jars. 2.50 m north of the middle of the southern wall was placed a third large jar without contents, and slightly further north the impression of another one was traced. Outside the northern wall of the residence block were found the remains of an adjacent structure containing in its north-

west corner the sherds of one more large vessel.

Houses F and G

East of the southern row of rooms of the Block E, i.e. in the alignment of the road, follows a baked brick structure consisting of two rooms, called house F here. It is separated from E by a 0.85m wide lane in which a gully is running lined with baked bricks.

House G, ca 4.0 × 7.0m in size, is erected of mud-bricks and extends in north-south direction. The openings towards west remind one of the large halls in the Levels 27 and 26.

Level 23

In Level 23 a number of residential plots came to light marked as Blocks A-F in the northern area 2 V-3 I/Ca-Cc, and as Blocks G-I in the more southern fields 2 IV/Be-Ca and 2 IV/Cc. The floor level descended slightly from 20.30m in the south to 20.00m in the northwest and, more strongly, to 19.10m towards east.

Unlike Level 24, where after the disintegration of the built-up area of Level 27 and its connected Levels 26 and 25 large building complexes were not yet planned again for the whole area, the structures unearthed in Level 23 gave the impression of well-contrived house-building activities following new conceptions of town-planning.

Although the general alignment of the houses and roads still followed the traditional directions and some of the buildings were even reconstructed on the walls of Level 24 (e.g. Block C), the altered orientation of the blocks and the establishment of new places and drives presented a completely different picture of the inner organisation compared with the strict formation in the Levels 27 to 25. The partly close structural connection with the one or the other house of Level 24 may, on the other hand, be interpreted as a completion of the building ideas already developed there.

Best preserved were the structures of Block A (Fig. 49) in 2 V-3 I/Ca, external dimensions ca 12.00 × 11.80m, surpassed in its size only by Block C situated to the southeast, measuring ca 14.00 × 14.30m.

The rooms of Block A centered from three sides on an inner courtyard. Due to the comparatively high raising walls, partly up to 1.00m, the position of the doors of most of the rooms were clearly recognizable. The western tract consisted of four rooms (nos. 2–5) of which no. 3 contained the remains of a fireplace made of clay, and no. 4 was furnished with a big jar. South of it fol-



48 Level 24: Eastern row of rooms of Block E



49 Level 23: Block A in 2 V-3 I/Ca



lows a small room (no. 5) which doubtlessly was used as a toilet, the first instance of such a facility within a residence of Sonkh at all. In a first phase of use this room was equipped with a brick gully and two large bricks on top for placing the feet when in squatting position. The water drained to the street while the excrements of the toilet remained in a pit. In a later phase the floor was paved with sherds and brickbats, and a pair of bricks was marking

the squatting spot (Fig. 50). On the floor of the toilet room stood two water jars, one for cold and one for hot water (mica vessel with burnt bottom). The toilet room also gave access to the southwest corner-room (no. 6). Equipped with a floor carefully paved with baked bricks and with a drain cutting through the southern wall it has to be regarded as the bathroom of the residence. One can take it as part of the southern row of four rooms (nos. 6-9) which

provides, through room no. 8, the main entrance to the whole block. The slightly staggered door-openings led to the inner courtyard showing remains of a pavement. In the southeastern room no. 9 the kitchen and the pantry of the residence were housed, furnished with a fireplace, a big water jar and storage bins built of baked bricks (*kothi*) (Fig. 51). In the southwest corner of room no. 7 a copper goblet has been found carefully put

down and covered with a copper bowl (see METAL OBJECTS, nos. 58a–b).

South of the Block A a rather large, approximately square place extended, enclosed by the partly excavated Block B in the west, the Block G in the south, and Block C in the east. This place was accessible only from the north, along the western wall of Block A via the ca 3.00 m wide drive between the Blocks A and B. The corners of the blocks in this spot as well as the southwest corner of Block C were protected against damages caused by vehicles (bullock carts) by two vertically placed blocks of sandstone, height 0.80 m, now partly dropped to the ground (Fig. 52).

Except slight differences in the layout and size, Block C is in accordance with the Block E of Level 24. Its brickwork was erected on the older walls using them as foundation and is, in spite of minor deviations in the arrangement of the rooms, to be taken as a reconstruction of the older structure and as a prototype of the emerging type of residential building.

The western row of rooms in Block C consisted again of four units of which the southernmost room showed a paved floor sim-



50 Level 23: Toilet in Block A



51 Level 23: Room 9 in Block A. Kitchen and Pantry



52 South-western corner of Block C with corner stone of Level 23 and superstructures of Levels 22–21

ilar to that in the bath of Block A. The southern tract could only be traced by the foundation ditches as the brickwork was completely missing, to be compared with the corresponding tract in Block E of Level 24. In the eastern row, the middle room represented most probably the kitchen, because here a number of fireplaces built of baked bricks covered with clay and a working platform made of brickbats were found.

The floor of the courtyard of Block C showed several phases of use, partly traceable in larger spots of baked brick pavement. Like in Block E of Level 24 here again the floor of the courtyard preserved in its different levels the impressions and remains of a number of big jars, diameter ca 0.60 m, partly placed close to the house walls or in the centre of the court.

The entrance to Block C most probably was situated on the road side in the south as in Block A. A second entry might have existed in the north leading directly into the courtyard as perhaps was the case in Block A too.

In the course of the road followed the structures of Block D towards east and the remains of the residences E and F to the north. The southern walls of Block C and D mark the northern border of the east-west running road which had the same course as in the earlier levels, with the exception that now the drive ends in the square in front of Block A.

A remarkable peculiarity of the Level 23 is the system of construction. The houses were, so to speak, built in sections. Vertical joints, 2 cm wide, prove that single units, i.e. rows of rooms were set one close to the other. Somehow, this recalls the set-up of the residential blocks in Levels 27–25, although the technique of construction was quite different. As not even a single roof-tile was found in Level 23 the roofs were obviously covered with some other material and are to be expected as having been flat-roofed.

The bricks of Level 23 measured generally $40.0 \times 25.0 \times 5.0$ cm, partly $41.0 \times 27.0 \times 6.0$ cm. As they were of medium fabric, the upper layers of the excavated walls were strongly weatherworn. In the foundations, the bricks were joined together alongside, thus resulting in a foundation width of 40.0 cm, on which the stretch brickwork was erected either flush, esp. with the outer walls, or partly centric on the inner walls. For such a thrifty use of bricks economical reasons might have been responsible. The modest thickness of the walls (0.25 m), partly strengthened by pillars at the doorways, combined with the inferior quality of

the bricks may have caused an early decay of the houses in Level 23. This conclusion is supported by the existence of an extensive area of overbuilding strictly following the given ground-plan, but mostly consisting of walls mixed of baked bricks and mud-bricks, or of mud-bricks alone.

G. THE KUṢĀṆA LEVELS

Level 22

This level is represented by a larger number of structures covering the areas of 2 V-3 I/Ca-Cc. The elevation, related to the average height of the bases of the foundations, differs from ca 20.30 m in the west to ca 20.00 m in the east. The brickwork was rising upto 0.50 m, showing some peculiarities to be discussed below. Of the floors in this level only scanty patches could be located in 3 I/Ca and 2 V Cb/Cc as well as in 2 IV/Be. The remaining walls in 2 IV/Be represent a structure rebuilt on Level 23. The structural fragments in the middle of 2 IV/Cc form the northern outer wall of a residence which, compared with the corresponding building in Level 23, has been

shifted slightly towards north but kept in alignment with the old course of the road. The most impressive construction in Level 22 was the residential Block C, measuring 11.60×12.60 m externally. It was erected on the spot of the Block C of Level 23 and Block E of Level 24. The western as well as the southern outer walls were in alignment with those of the earlier residential blocks, thus preserving the former street front. The smaller dimensions compared with Block C of Level 23 were caused by shifting back the eastern and northern walls. The altogether seven rooms preserved of the building were placed to the south and west of the large inner courtyard. They measured ca 3.50 m in width and had conspicuously strong walls, its thickness ranging between 0.60 and 0.70 m (Fig. 53).

As far as evident, Block C stood rather detached or was, if the walls towards east have to be taken as an indication of further structures, the first and corner building of a flight of houses. In the north it was bordered by a new road running in front of Blocks A and B as well as E and F.

Block A was an isolated, perhaps minor building with only two rooms and was sep-



53 Level 22: Southern row of rooms, Block C, from east



parated from Block B by a passage widening from 1.50 to 1.80m towards the road. Of Block B only the southern wall together with the remains of a few rooms were preserved. The northern part of this building and of the other blocks following towards east was destroyed by the digging of the large moat of Level 4. Noteworthy is the enormous thickness of the outer and the supporting walls of the room tracts mea-

suring 0.60–0.70 m. The lower edge of the brick foundations ranged between 20.20 and 20.35 m, the upper edge of the brickwork lay at max. 20.95 m. The southwest corner room (no. 3), however, was found to be founded on a rather astonishingly deep level, the lower edge of bricks ranging between 18.83 m in the southwestern, and ca 18.32 m in the other corners. In relation to the upper edge the brickwork of the

rather small room was rising upto ca 2.50 m, inside dimensions ca 1.20 × 2.00 m (Fig. 54). There is no clear explanation for such a deep basement of this room. It might have been a kind of cold-storage chamber, but one cannot exclude the possibility of other functions as it is situated in the southwest corner of the residence where in Level 27 to 25 a ring-well was placed or where, in later levels, normally



54 Level 22: Deeply based storage chamber in Block B



55 Southern tract, Block C, Levels 22 and 21 (Phase 1)

water jars were found. Therefore it might be possible that the construction of a well was started but not finished.

Towards east followed, separated by a ca 4.50m wide passage and shifted slightly northwards, the Block E with the remains of four rooms along the southern road front. Even less was preserved of Block F which, after a narrow passage of 0.70m, was the next building in the line along the new road. Just in front of the southern wall small patches of a mud and brick pavement could be preserved.

To the west of Block C structural remains of Blocks D and H came to light. Rebuilt on the ground-plan of Level 23, they are partly to be taken as later phases of that level.

With the exception of Blocks B and E the structures of Level 22 were built chiefly of brickbats, showing thereby that the remains of buildings unearthed have mostly to be taken as foundation walls.

Level 21

With regard to the Apsidal Temple no. 1 and the protection of other, mostly later, well-preserved structures the lower levels have been excavated in the northern area only, except regions 2 IV/Be and 2 IV/Cc. Level 21 is thus the earliest one in the mound of Sonkh the building structures of which could be traced all over the main excavation area, comprising the squares 2 III-3 I/Be-Cc extending over ca 60.00m in west-east and north-south direction, i.e. 3600 m².

The structures of the early phase of Level 21 (Phase 1), which on account of the just mentioned limitation could be unearthed in the northern area only, were erected closely on the foundation of Level 22, the thickness of the walls yet reduced to mainly 0.40–0.45m.

Block C (Fig. 55) corresponds with regard to the ground-plan to the building in Level 22 but shows slight differences in the arrangement of the rooms and, as pointed out, in the thickness of the walls. A projecting structure outside the northern wall of the block indicates that the road of Level 22 had lost its function.

In line with the southern outer wall of Block C further structures have been unearthed which take up the road axis already existent in much older times. The two long and narrow rooms of this Block G, measuring 3.40 × 17.40m, might have formed the southern border of a courtyard, perhaps used as stables.

Like in Level 22 the Blocks B, E and F form the northern boundary of the



built-up area so far excavated. Concerning Block B it was difficult to distinguish between structures of the Levels 22 and 21, the brickwork being reused and rebuilt again and again. Slight differences in the brickwork as well as occasionally varying foundations and additional structures based on a higher level were the only signs of alterations. While Block E followed the old plan, Block F has been based anew and shifted slightly northwards in order to get

more in line with the afore-mentioned block. The remains of the westernmost Block D showed no remarkable differences in comparison with Level 22. The elevation of Level 21, related to the average height of the bases of the foundations ranged between ca 20.90 m in the west, ca 20.50 m in the east and ca 20.30 m in the north. In a later time of Level 21 (Phase 2) Block C

has been abandoned. The long and narrow structures of Block G formerly adjoining Block C towards east have developed now into two units separated from each other by a joint, the western one of which preserved five rooms in its southern tract. Other scanty remains of structures in 2 V/Cc could not be definitely assigned to further buildings extending too far into the unexcavated area. In place of the Blocks E and F, formerly forming the northern bound-



ary, remnants only of a long enclosure wall came to light.

The remains of structures in 2 IV/Ca did not betray a clear layout, but the arrangement of walls pointed to a built-up area of residences having been destroyed, in its majority, by the foundation work in later levels.

The average height, related to the bases of the structures in Phase 2 of Level 21,

ranged between ca 21.20/21.40m in 2 IV/Be and 2 IV/Ca, and ca 21.00/20.80m in 2 V/Cc.

Level 20

Although quite a number of walls and fragmentary structures were found all over the excavated section, Level 20 did not show any clear, complete structural units be-

cause the whole area was extremely ruined by the foundation work of later levels (Fig. 56). The layout imaginable by the remaining walls lead to the assumption that the buildings of this level were residential buildings following in their alignment and arrangement the traditional rules of town planning. The southern fringe of structures in 2 III/Cb now clearly marks the place in the centre of which the Apsidal



56 Remains of structures of Levels 21/20 (left) and 19 (right)

Temple 1 is situated (see *The Apsidal Temple no. 1* below).

The buildings of Level 20 partly used the walls of Level 21 as foundations especially recognizable in 2 V/Cb-Cc. Noteworthy is the fact that the axis of the ancient road of Level 27 survived all changes with only slight deviations.

The elevation of Level 20, related to the average height of the bottom of the foundations, ranged between ca 21.40m in 2 IV/Be, ca 21.70m in 2 IV-2 V/Ca-Cb, and ca 21.00m in the eastern area.

Level 19

With the structures unearthed in Level 19 came to light for the first time a closely built-up area in the *southern* section of the excavation giving a clearer idea of the type of buildings constructed in the time after Level 22.

In the north, i.e. in 2 V/3 I-Ca/Cb, only fragmentary structures were found, a fact which might indicate that at this time only minor buildings have been erected here, while the centre of habitation had shifted more towards south. Remains of an enclosure wall southeast of Block D nevertheless show that the ancient road line and the northern border of the temple place were still partly preserved.

A most impressive sight was the densely built-up complex of Blocks E–I in the sou-

thern region of 2 III/2 IV-Ca/Cb. The Blocks E and F, of approximately same dimensions, showed a nearly identical layout consisting of a rectangular inner courtyard of ca 4.00 × 5.80m, enclosed by rows of rooms on three sides, identical even in the number and different sizes of rooms in the western, southern and eastern row. The rooms seemed to be arranged symmetrically in relation to the intermediate courtyard which might have been common property.

Block E (Fig. 57), external dimensions ca 9.35m (estimated) × 9.20m, and Block F, ca 9.20 × 9.50m, are matching also in the method of construction up to the way in which the courtyards are paved. Unclear remains, why the inner courtyard of Block E (average level of pavement ca 22.30 m) has been divided in its northern part by a line of upright bricks, leaving the northern part unpaved. In the corner formed by this line of bricks and the wall of the eastern tract stood a large storage jar sunk into the floor. A number of rectangularly placed upright bricks in room no. 6 presumably represented storage bins.

In Block F, room no. 10 has got an additional pavement. The eastern wall, not in alignment with the southern part, seems to be a later structure perhaps substituting collapsed brickwork. The average level of the brick pavement in Block C lay at ca 22.15m.

The courtyard between Block E and F was open towards north (width ca 4.40 m) and preserved in its southeastern corner a carefully paved rectangular platform of ca 2.90 × 2.00m, average level at 22.35m, re-

presenting perhaps a threshing floor. The structure in front of the southern wall seemed to form a large storage bin.

Block G, extending immediately south of E and F, was of larger dimensions. Its eastern border wall was set back from the line of Block F by ca 4.30m. The inner structures of the complex were missing, but the remains of the eastern and southern room tracts point to overall dimensions of more than 12.00 × 12.00m. The space between G and F was closed by a brick-wall indicating that the entrance to Block G is to be expected in the west. In accordance with the slightly sloping ground Block G, and perhaps the adjoining residences, were drained by a walled gully discharging the water on to the open place. The southern outer wall of Block G, in contrast to the usual brickwork of ca 0.40m, showed a thickness of ca 0.70m, denoting hereby that the building has perhaps to be regarded as two-storied.

While the main structures discussed till now followed more or less the ancient alignment, deviating slightly from the west-east course, the northern front walls of Blocks H and I were erected nearly exactly in west-east direction. The structures of these blocks, forming the southern boundary of the place around Apsidal Temple no. 1, do not permit a complete reconstruction. Of Block H has been unearthed a two-roomed building adjoining the northern outer wall, to the south might have followed a large courtyard. The structures on the eastern side of Block I seem to be the remains of a row of rooms directed north-south.



57 Level 19: Block E and courtyard between E and F, from west



of holes... in the...
 Level 11...
 in the...
 fragment...
 which...
 more...
 while...
 the...
 show...
 recent...
 still...
 A...
 built...

Level 18

This Level brought about a remarkable change in the hitherto rather uniform process of settlement in the mound of Sonkh. Starting with Level 27 it was possible to pursue the alterations from level to level, to watch how succeeding levels were adapted to the given condition taking into consideration for their development the surviving structures of the earlier settlements and integrating the remains of former buildings or walls. With Level 18 the situation changed completely.

Conspicuous was the compact floor level, covering the remains of previous levels as a whole extending to 56.00 m in west-east direction and ca 50.00 m north-south.

The compact floor, traceable nearly all over the whole area, consisted of a layer of crushed sherds and brickbats embedded in hard clay. Incorporated into this layer were the walls of earlier structures marking themselves in the floor (Fig. 58).

Another peculiarity is the occurrence of gully-like grooves, 20.0–25.0 cm wide and ca 15.0 cm deep on the average. They are mostly several metres long, in one case more than 10.00 m, and arranged partly in pairs, average distance ca 1.00 m. The profiles shed at least some light upon the function of these grooves. While in use, the gullies must have been lined with slopes of clay or sand rising ca 20.0 cm above level. The channel thus formed, ca 30.0–35.0 cm deep, was presumably plastered with clay which in use (burning) turned reddish. Without exception, the gullies were filled with grey ashes, fragments of charcoal and sand (Fig. 59). Due to the lack of further information, the exact function of the gullies still remains in the dark.

Noticeable are the circular platforms measuring between 1.25 m and 3.00 m in diameter, partly covered with layers of grey-black ashes. These platforms had, like the gullies, no direct connections with the buildings unearthed in this level.

The height of Level 18 ranged between ca 22.90 m in the southwest (2 IV/Be), ca 22.40 m in the northwest (2 V-3 I/Ca) and, strongly sloping towards east, ca 21.00 m in 2 IV/Cc and 21.60 m on the average in 2 V/Cc.

The residential buildings of Level 18 had, as already mentioned, no connection anymore with the previous structures, the orientation deviating, though slightly, from the up to now traditional direction.

In the excavated area of this level the remains of four residential quarters, i.e. Blocks A–D, could be unearthed.

Block A, extending along the western excavation boundary about 13.00 to 14.00 m



58 Level 18: Floor of crushed sherds and brickbats with round platform and contours of earlier walls

NS, was showing a slightly irregular layout. The excavated part consisted of two rooms of the southern tract and remnants of built-in structures of the walled-in courtyard.

In 2 V/Cb the southern section of Block B was preserved, consisting of four rooms, ca 3.10 m wide, extending for ca 9.70 m in east-west direction. Remains of an enclosure wall at the eastern end of the block indicate that this southern unit was adjoined towards north by a courtyard with further structures.

The Blocks A and B were standing rather isolated within the excavated area in a distance of ca 12.00 m in between.

In Level 18, the Apsidal Temple no. 1 was surrounded by a now much larger open space than before. Traces of a more densely built-up area were only found to the southwest in 2 III/2 IV/Be-Ca/Cb denoting that the unexcavated inner region of the mound might be hiding the residential center of Level 18, perhaps also indicated by the fact that the terrain is strongly ascending in this direction.



59 Level 18: Gully-like groove in the compact floor



Of Block C only the northern outer wall, remains of the courtyard, and remnants of rooms as well as built-in structures have been found.

Block D, extending ca 12.70m west-east, preserves a long stretched room on the eastern side with a front structure in the north.

While the residential blocks of the preceding levels consisted usually of a courtyard

enclosed on three sides by rows of rooms, the structural situation in Level 18 lead to the assumption that now the layout of a residential block was based on a southern row of rooms with a courtyard adjoining to the north in which here and there annexes were erected. The material of the rather carelessly erected walls consisted mainly of reused baked bricks. The blocks were not generally built in alignment, the

enclosure walls of a block not in all cases constructed parallel to each other.

Although not convincingly executed, the structures of Level 18 laid the foundations for the layout and construction of the succeeding levels, especially the "rich" Level 16.



Level 17

The excavation yielded only scanty remains of profane buildings safely to be assigned to Level 17. Yet, rather impressive were the structures of the Apisidal Temple no. 1 of which two further phases could be unearthed. In this period the temple reached its largest extension with 9.85×8.85 m. For a detailed description see *The Apisidal Temple no. 1* below.

While the ground in Level 18 was strongly descending from west to east, the soil around the temple was now considerably raised or filled up. The height of the floor measured ca 22.70–22.30 m compared with the ca 22.00–21.40 m in Level 18.

The few fragments of walls in 2 V/Ca-Cb of Level 17 did not suggest a continuation of former constructions (cp. Blocks A and B of Level 18), but towards east, in 2 V/

Cb-Cc, were found remains of various structures which, although mainly damaged, denote a more densely built-up area.

In the inner part of the settlement, i.e. in 2 III–2 IV/Be-Ca/Cb, some structures of Level 18 were resumed, as for instance the northern wall of Block C of Level 18 and the eastern border wall as well as the row of rooms of the former Block D. However,

the scattered remains of brickwork do not allow to reconstruct the complete layout of the two blocks.

It needs to be mentioned here that the preservation of structures of Level 17, like Level 18, had been severely impaired by the deep foundations of Level 16.

Level 16

On top of the few structural remains of houses in Level 17 were raised the walls of altogether seven blocks of Level 16 forming an urban ensemble to the north and southwest of the remnants of the Apsidal Temple no. 1. The Level 16 is the uppermost and final Kuṣāṇa level at Sonkh and the last level showing a closely built-up complex for a long time.

The greatest concentration of structures of Level 16 was found in the southwestern part of the excavation, an area of ca 20.00 by 30.00m, covered by astonishingly well-preserved and high-raising remains of walls of several blocks (Fig.62). There have been exposed three buildings showing nearly complete ground-plans (Blocks A, B, C), and the northern walls of a fourth one (G). To the north of this group, separated from Block C by a passageway, fragmentary walls of another building (D) were projecting from the western section profile in 2 V/Be-Ca. Northeast of this building further structures of two smaller houses were excavated of which, unfortunately, only fragments of foundation walls survived. Between these two buildings and the southern group of blocks no indications of building activities were met with. A look at the layout of the level suggests that the blocks excavated in this area, in all probability, constituted the southern, western and northern side of an open place of ca 18.00 by 23.00 metres west of the temple. At the northwest corner of the place a road was leading towards north as did the mentioned passageway towards west. The ground was slightly ascending from north to south, in the north the level ranged between 22.80 to 23.45m, in the south about 23.40 to 23.85 m.

All the buildings encountered with have been residential blocks. They obviously formed the centre of the township in a layout slightly different compared to the former Levels 18 to 21, in spite of the occasional reuse of older walls as foundations for the new structures.

The blocks were built closely to each other but, in contrast to the earlier levels, they never had a common wall, yet were always separated from each other by a narrow gap measuring 30.0 to 70.0 cm. This system of



60 Level 16: Blocks A (upper left) and B (lower right)

drainage lanes, appearing as dividing lines between neighbouring dwellings, is clearly visible in the complex of the Blocks A, B, C and G. While the northern houses could be exposed only in their foundations, the walls of the southern blocks A, B and C were rising partly to a height of 2.00m (Fig.60).

The buildings mostly followed a general alignment, slight deviations being partly due to the fact that all the blocks have un-

dergone several phases of habitation with all the unavoidable minor changes and structural additions.

The roofs must have been constructed in perishable materials as indicated by rotten plant-remains and fragments of loam coating found in several rooms. About the shape of the roofs only conjectures can be made. Judging from the way the houses were constructed flat roofs are to be assumed.



61 Level 16: Northern tract of Block C and passage way



62 Residential Blocks in Level 16

The blocks were built in baked bricks exclusively, often taken from older structures and reused for the new buildings. As in all the Kušāṇa levels the average size of bricks was $37.0 \times 23.0 \times 5.0$ cm. As the bricks were, as a rule, placed lengthwise, the thickness of the walls measured mostly 37.0–38.0 cm.

Block A measured ca 7.50×15.00 m, Block B ca 7.50×13.80 m. In the rather large Block C, consisting of sixteen rooms and courtyards of different sizes, the simple layout of the Blocks A and B with their courtyard and the southern domestic tract has here been enlarged by additional structures erected in successive phases of habitation. Originally the southern tract consisted of four rooms too, the fifth being added later in connection with the eastern courtyard and the rooms following north (Fig. 61). Thus, the block formerly measuring 10.00×10.00 m, in the last phase of use covered a space of 13.00×14.00 m. The drainage system consisted of brick-gullies leading from the central courtyard to the eastern one.

The centre of the block is the square courtyard to which all the surrounding rooms are opening. Special attention needs room 2, i.e. the second from the left in the southern row, where on its lowest floor level in 2 IV 5.8/Be 17.3, H. 23.80 m a small pot with 120 Kušāṇa copper coins was found (types see COINS, nos. 91–100; 103–106).

In the same room a small storage bin built of upright standing bricks was located, first in the southeast corner, later on a similar one at the northwestern side. Another important find within this block is to be recorded from the upper habitation layers of the central courtyard in 2 IV 9.5/Ca 0.1, H. 24.28 m, where a double-figured Kušāṇa



63 Level 16: Curvilinear wall of Block E



bronze has been found, which presumably has survived from earlier Kuşāna levels (see METAL IMAGES, no. 2).

The walls of the Blocks D, E, F and G could be traced only in their foundations. The layout of rooms could not be reconstructed beyond doubt, although the southern row of rooms showed similarities with those of the more complete structures. Block E was built with a curvilinear wall at its southwestern corner, indicating

the course of a road running towards northwest (Fig. 63).

Comparing the layout of the roofed rooms within the complexes the similarity of the arrangement is striking. All the buildings have in their southwest corner a small room, the inner width never exceeding 1.00m, always followed by two wider rooms and mostly one smaller one to the east. Moreover, the depth of the row of rooms is always 3.15m. This size has been a

favourite one since Level 21 and has been adopted also for other rows of rooms in larger buildings, as here in Block C.

As proven in former levels, beginning with Level 27, the small southwest room also here is the room for the water supply. A large water-jar of more than 1.10m height in the respective room in Block B is sufficient evidence for this interpretation.

About the situation of the main entrances to the blocks only conjectures can be of-

ferred. For the Block C the northern side along the passageway is the only possible and most probable side of access. Block B was, in its earliest phase, presumably entered from the north but seems to have changed the entrance over to the eastern side later on. Block A might have been neighboured by a further block to the south, so that only the east or, less probable, the southeast corner remains as a possible place for the entrance.

The Apsidal Temple no. 1, maintaining its position in the open space in the area 2 IV/Cb through all the Kuşāna levels, reaches its final phase of use in Level 16. It is now, at least in its last phase, no apsidal structure anymore because the apse had been filled up with debris, rubble and earth for the construction of a platform built of brickbats with the surface at ca 23.95 m and measuring 6.70×6.20 m. On the eastern side an additional structure of a depth of ca 1.00 m served as a base for a staircase platform, to be entered by the narrow sides from north and south. The outer wall of the temple, still measuring 9.70×8.85 m in Level 17, was covered now by the remains of a floor first laid at an average height of 23.40 m, the level of the floor increasing in height rapidly during the habitation period of this level so as to make it even with the platform finally.

H. THE APSIDAL TEMPLE NO. 1

At the end of the campaign 1969/70, when the excavation of Level 16 was in progress, some brickwork structures were unearthed which, with regard to their position in the centre of the place in 2 IV 9.00–19.00/Cb 7.00–18.00 and their constructional appearance, could easily be interpreted as remains of a sacral building. The continuous efforts to clear the situation during the next campaigns were successful. In close succession were found earlier and in the dimension larger structures confirming by their architectural shape the assumed function of the building as a temple.

It seems necessary to point out that beginning with Level 17 the investigation of the temple was confined to the interior because the decision to preserve the whole edifice did not permit a deeper digging on the outside. The reconstruction of some parts of the temple structure as well as the exact definition of the length of the lateral walls of the apse was, in addition, rendered difficult by a ditch sunk in from the moat of Level 4, which damaged parts of the lateral walls.

The connecting link of all the established phases of use and reconstruction of the temple, aligned approximately in east-west direction, was the apse as the ritual centre of the building. According to the changing height, form and direction of the outer walls the apse was submitted to slight alterations, but with regard to its dimension and opening towards east it had been used, reused or rebuilt nearly without change through most of the levels. The only exceptions being Phase 9 (Level 16), including a possible later superstructure, and the presumably earliest Phase of Level 22.

On account of the knowledge gained during the excavation the edifice has doubtless been used as a sacred building throughout the Kuṣāṇa time, yet subject of constant reconstructions, enlargements and over-buildings which for the most part can be assigned to distinct levels. Thus roughly nine different phases could be distinguished. But it is quite probable that in addition some intermediate phases have to be assumed which, due to the difficulties mentioned above, could not be determined without an excavation of the outside area of the temple.

Phase 9, to be assigned to Level 16, has to be seen as a platform construction accessible by two steps each from the north-eastern and south-eastern corner (see plan of Level 16). Outer height: upper edge ca 23.95m, lower edge ca 23.00m; superstructure of the apse: upper edge ca 23.95m, lower edge ca 22.80m. In a later

phase of use the steps were partly overbuilt and the platform was provided with an additional structure on the eastern side. The platform was rising relatively high over the ground sloping from south to north from ca 23.40m to ca 22.80m. The existence of an apse in this period is doubtful because of the find of structural remains of a room set back about 1.00m from the edge of the platform into which an apse would not have fitted properly. The apse of the next lower phase was, in addition to this, situated off the centre so that a continuous use in Level 16 can most probably be excluded. The outer dimensions of the platform measured ca 7.80 × 6.20m, the probably square shrine ca 3.80 × 3.80m with a gallery of ca 1.20m.

Phase 8 and 7 (Fig. 64), contemporary with Level 17, showed considerable alterations in the structural form of the temple. The excavated apse turned out to be a semicircular structure with the opening towards east, having a diameter of ca 3.00m. The lateral walls of the apse were, as already mentioned, damaged in later time so that only parts of unequal length could be traced. The longer one measured ca 2.50m with a thickness of ca 60.0–65.0cm. The upper edge of the apse lay at ca 23.30m.

In Phase 8 (Level 17, Phase 2) the apse, being situated somewhat out of centre, was enclosed by a ca 50.0–55.0cm thick wall on its northern, western and southern side. The bricks used were of the sizes 37.0 × 23.0–24.0 × 5.0cm. East of the apse came to light a narrow, longish entrance room (outside ca 2.30m, inside ca 1.50m wide), which was placed in front of the enclosure walls with a joint, slightly receding from the wall in the south. A few remnants of walls point probably to a later partition into smaller rooms.

The outer dimensions of the whole structure amounted to ca 9.70 × 8.85m. The upper edge of the outer wall lay at ca 22.90m on the southern, and ca 22.70m on the northern side. The lower edge of the brickwork is fixed by the preserved structure of Phase 7. The surface height of the place around the temple has been measured with averagely 22.70m in the south, 22.60m in the north, and 22.30m in the east.

Surprisingly, the western corners of the temple were rounded, following thus the brickwork of Phase 7 which, at the same time, was used as foundation.

At the inner side of the enclosing wall were found ca 25.0cm wide brick projections lined up in irregular distances ranging between 1.20m and 2.60m and protruding partly up to 40.0cm. It remains unclear whether these projections were construc-

tional brick pillars, rather improbable because of the irregular setting, or whether they were pilaster-like projections for decorative reasons or to achieve niches for placing idols.

Within the temple has been exposed a larger space of a floor consisting of hard clay, sherds and brickbats which extended even into the apse at a height of 22.56m. In the apse has been found a 60.0cm high plinth placed into the round of the apse and smoothly built on the foreside. Covered with a slab it was used most probably for the installation of an image. Such an assumption is supported by the find of a stone relief lying directly at the base (see *STONE SCULPTURES*, no. 1).

Phase 7 of the Apsidal Temple no. 1 belongs likewise to Level 17, but to its earlier phase of use. The upper edge of the brickwork lay at ca 22.55–22.19m, its lower edge at ca 22.12–21.50m. The characteristic sherd-floor of Level 18 was running on the outside directly under the lower edge of the base of this phase of the temple, descending from ca 22.00m to 21.40m in the direction south-west to north-east.

In its outer dimensions of ca 9.85 × 8.85m quite similar to Phase 8, the new phase differs in so far as now all the four corners are slightly rounded, radius ca 50.0cm, width of the outer wall ca 60.0cm, size of the bricks mainly used 38.0 × 23.0 × 5.0–5.5cm. The lowermost layers of the foundation were angularly laid and the bricks, therefore, slightly displaced due to the weight of the brickwork causing the outer walls to get inclined outward. A division of the interior, as indicated by the projections in Phase 7, was not recognizable anymore. During the excavation of the interior space below Phase 7 within the enclosure walls of Level 17 came in sight a number of approximately parallel structures close to each other but founded on different levels. So far, the outer dimensions of Phases 6 and 5 could be traced properly, both to be assigned to Level 18 (Fig. 65).

In the former Phase 6, outer dimensions ca 8.40 × 7.60m, a rather badly preserved structure was constructed of brickbats mostly. The walls of different breadth could be traced in the foundation mainly. The average thickness was 50.0cm, the upper edge lay at ca 22.50–22.00m, the lower edge could not be fixed. The outer walls of this phase were partly founded outside the walls of Phase 5, close to the older brickwork, whereas on the eastern side, the brickwork of Phase 5 has been used as foundation. The interior did not show any division belonging to this phase but it



64 Apsidal Tempel no. 1. Phases 8 and 7, from east



65 Apsidal Temple no. 1. Phases 8, 6 and 5. Levels 17.2 and 18.2-1



66 Apsidal Temple no. 1. Western side. Phase 5 (left), 6 (middle), 8 upon 7 (right)

might be possible that the layout of Phase 5 determined the situation in Phase 6 too, because the inner walls of Phase 5 were partly preserved on a higher level than the foundation walls of Phase 6. In the north-east corner of the brickwork a votive bowl was embedded.

The outer dimensions of Phase 5 (Level 18, 1st Phase) amounted to ca 7.70×6.50 m, as far as ascertainable. The foundation walls consisting mostly of brickbats were 70.0 cm thick. Upon this base the main walls were erected flush with the outer side of the foundations in a thickness of ca 40.0 cm; the bricks used measured 38.5×23.5 – 24.0×5.5 cm. The height of the southern outer wall lay at ca 22.50–21.75 m, in the north at ca 22.25–21.30 m. The height of the floor outside the temple came to averagely 22.05 m in the south-west and 21.45 m in the north-east (Fig. 66).

In Phase 5 have been found for the first time partition walls erected sideways of the apse, as it was characteristic for the lower phases. Preserved only as foundations, they were built upon the structures of Phases 4 and 3. Most probably, these walls served as support of the base of apse only,

so that a circumambulation of the apse remained possible by a gallery of ca 1.25 m in the north, ca 1.50 m in the south, and ca 0.90 m in the west. The structures found in Phase 5 permitted to determine the length of the apse with approximately 3.60 m, the diameter remained unchanged (3.00 m). East of the apse were found remnants of built-in structures which indicate a room or a platform in the entrance area.

While in the Phases 5 to 8, Levels 18 and 17, the temple building had constantly been enlarged, the structures of the lower Phases 4 and 3, perhaps also Phase 2, were disclosing no substantial alterations of the inside measurements of the temple. Only the southern outer wall was showing slight changes in its alignment, while the remaining walls, using just the older ones as foundation, were set one above the other, partly even without a joint. For these phases it proved impossible to determine the thickness of the walls and the outer dimensions.

Phase 4, erected in the time of Level 20 and most probably used up to Level 19, shows an inner room of ca 6.30×5.00 m. The height of the clearly distinguishable southern wall lay at about 21.85–21.65 m. Belonging to this phase is a clearly marked segment of the apse with its upper edge at 21.84 m and the lower at 21.72 m. Furthermore, it could be ascertained that the apse, in its upper phases nearly circular, displayed now, on its inside, more of the shape of a flat curve.

East of the apse were found the remains of a platform consisting of several layers of baked bricks. The partition walls to the south and north of the apse, as found in Phase 5 already, based on those of Phase 3, indicating thereby that they were in use during all the earlier phases.

Phase 3, approximately identical in the inner dimensions with Phase 4, i.e. ca 6.30×5.00 m, was most probably contemporary with the second phase of Level 21. The height of the slightly projecting southern wall lay at averagely 21.65 m with its upper edge, and 21.05 with the lower. The eastern wall, unlike the others founded separately on a clay base, measured at its north-east corner ca 21.24 m with its upper edge, and 20.76 m with the lower (Fig. 67). The height of the apse belonging to this phase of the enclosure wall, lay at averagely 21.70 m, the lower edge at 21.10 m, on the inside. The inner curve of the apse had, even more distinctly than in Phase 4, the shape of a flat curve. Moreover, it could be ascertained that the apse in this phase, most probably for the first time, had been built



67 Apsidal Temple no. 1. Southern inner wall. Brickwork of Phases 3 to 8

in a thickness of 60.0–65.0 cm, valid from now for the phases to come. This is supported by the fact that in this phase the formerly 40.0 cm wide lateral walls had been overbuilt. A clay level within the apse lay at a height between 21.52–21.64 m.

In addition to the partition walls to the south and north of the apse, as found already in Phases 4 and 5, came to light similar walls on the western side, erected radial to the apse (Fig. 68). It looks as if static reasons were responsible for these built-in structures taken over from Phase 2, where they were necessary as support because of the thinner wall of the apse.

East of the apse had been unearthed the remains of a brick wall in front of which a lower placed entrance platform could be traced.

On account of the limited space remaining for further clearance of the structures lying below the second phase of Level 21, the earliest shape of the temple could not be definitely made out. But it seems that in the time of Level 22, to which, according to the levelling, the deepest layers in the temple had to be assigned (Phase 1), no apse existed in the centre of the temple. Instead of it, the centre seems to have been filled by a deep-founded block of baked bricks, ca 3.05×3.30 m, enclosed in slightly irregular distances by more than 60.0 cm wide outer walls forming a square with an inside width of ca 3.75 m, upper height of ca 21.00–20.12 m. Upon this block the first round apse (Phase 2) had been erected in the time of the first phase of Level 21. At that time, the apse and its lateral walls were ca 40.0 cm thick. It remains unclear whether the apse was completely round already and the wall running through the apse has to be regarded as a structure built in subsequently. Belonging to this Phase 2 are numerous partition walls running radially towards the centre of the apse, which were similarly found up to Phase 5 of the temple in Level 18, because they were needed as structural support to the initially thinner apse.

In Phase 2, the upper edge of the apse lay at ca 21.50 m at its outer side, and ca 21.10 m at the eastern end of the lateral walls. East of the apse were found several parallel running walls which again support the interpretation that the lower structures belong to an early Phase 1 without an apse, while the extension with the erection of the apse is to be associated with a later Phase 2. There is, at the same time, enough reason to expect the outer dimensions of the structure in Phase 1 to be rather square as the assumed eastern wall of this phase is situated



68 Apsidal Temple no. 1. Partition walls erected radial to the apse



69 Apsidal Temple no. 1. Corner stone of Level 23 embedded in the lowest phase of the southern inner wall

ca 1.40 m within the enclosure wall of the Phases 3 and 4.

To what extent one would expect older phases of the temple below the structures of Level 22 must remain in the dark because of the limited area left for further ex-

cavation. Yet, worth to be mentioned is a large block of sandstone embedded in or overbuilt by the southern inner wall of Phase 2, possibly at the south-east corner of the temple of Phase 1 (Level 22), a corner-stone so typical for Level 23 (Fig. 69).

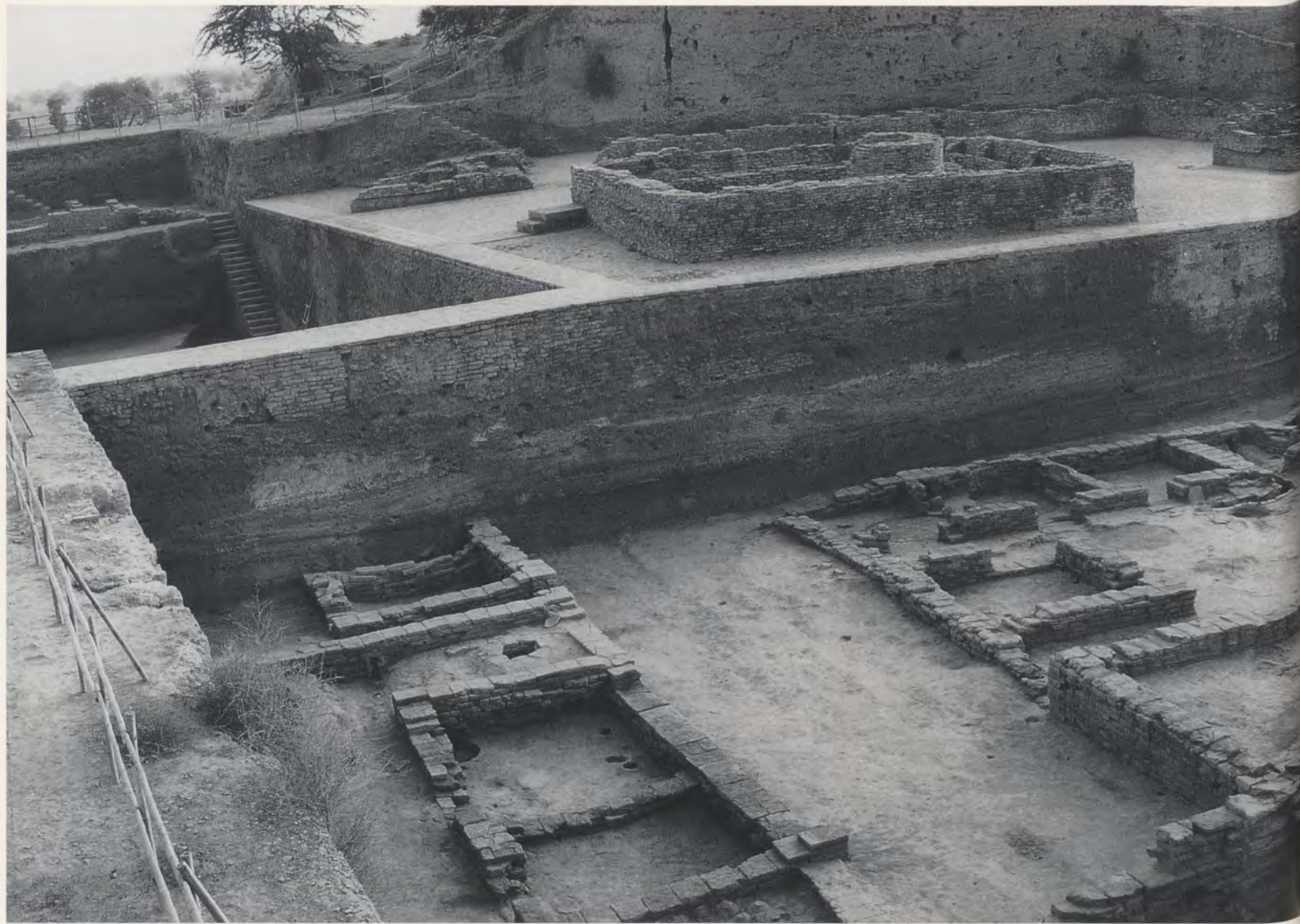

70 Main area of excavation

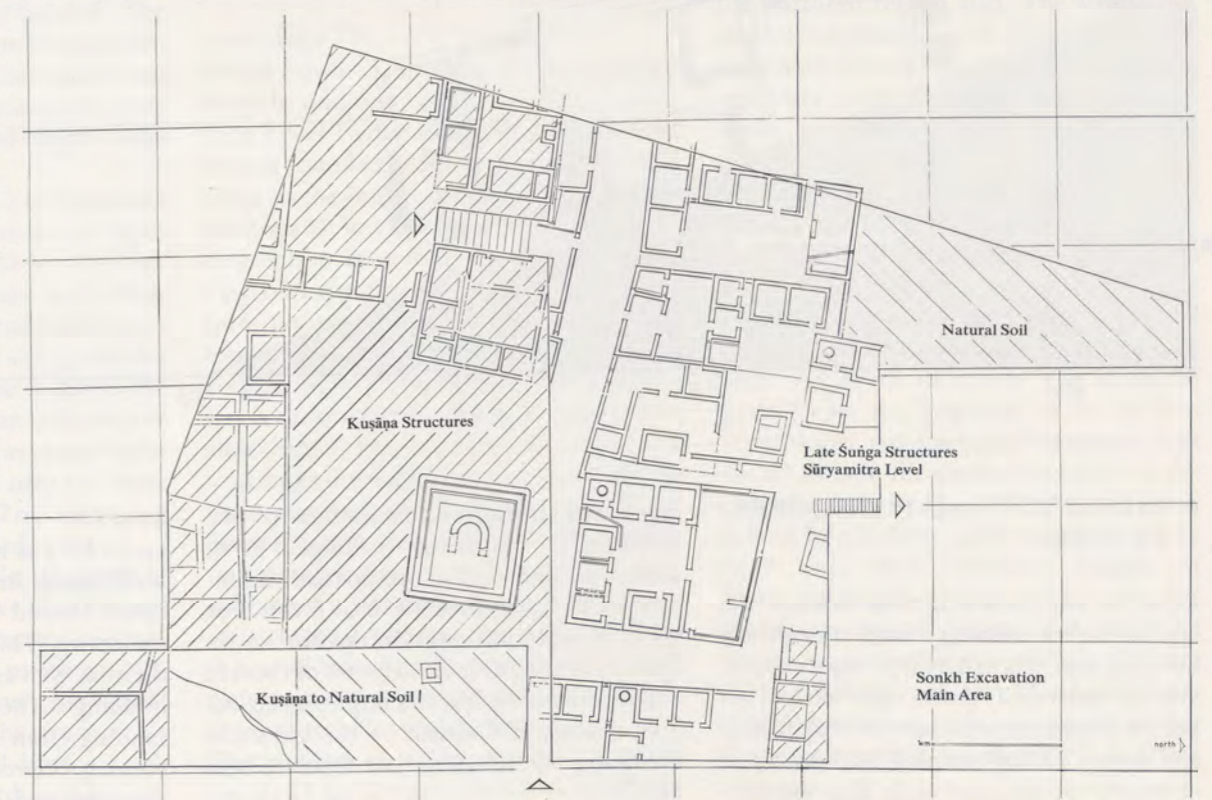
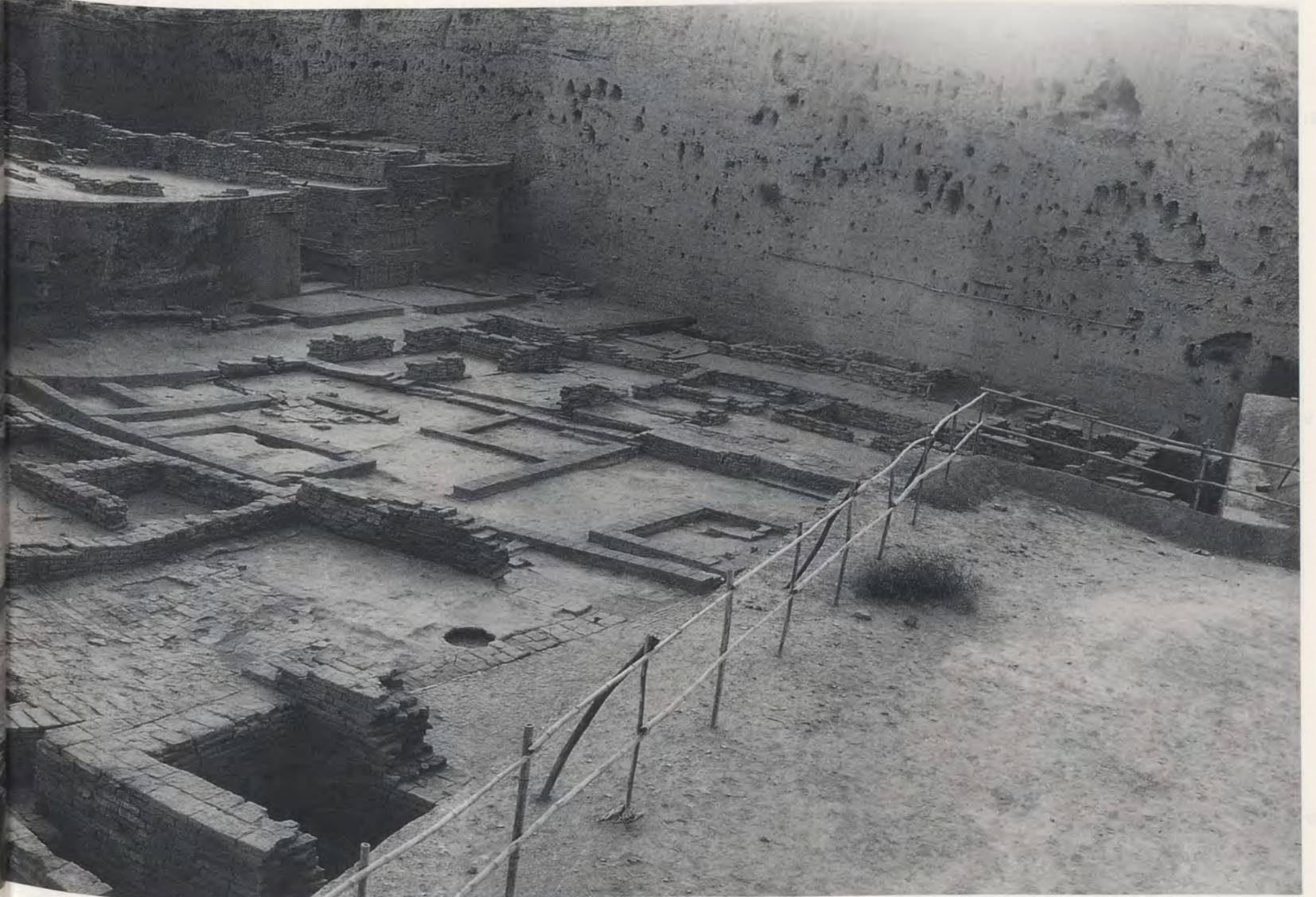
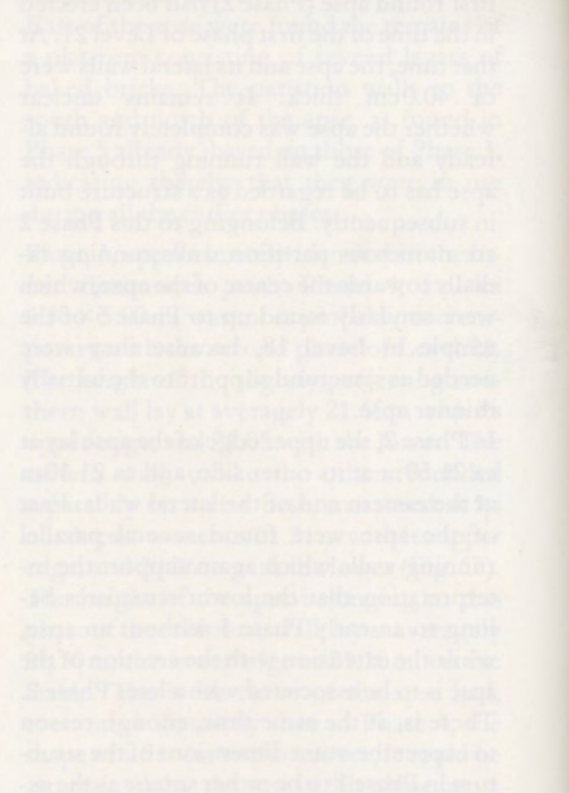

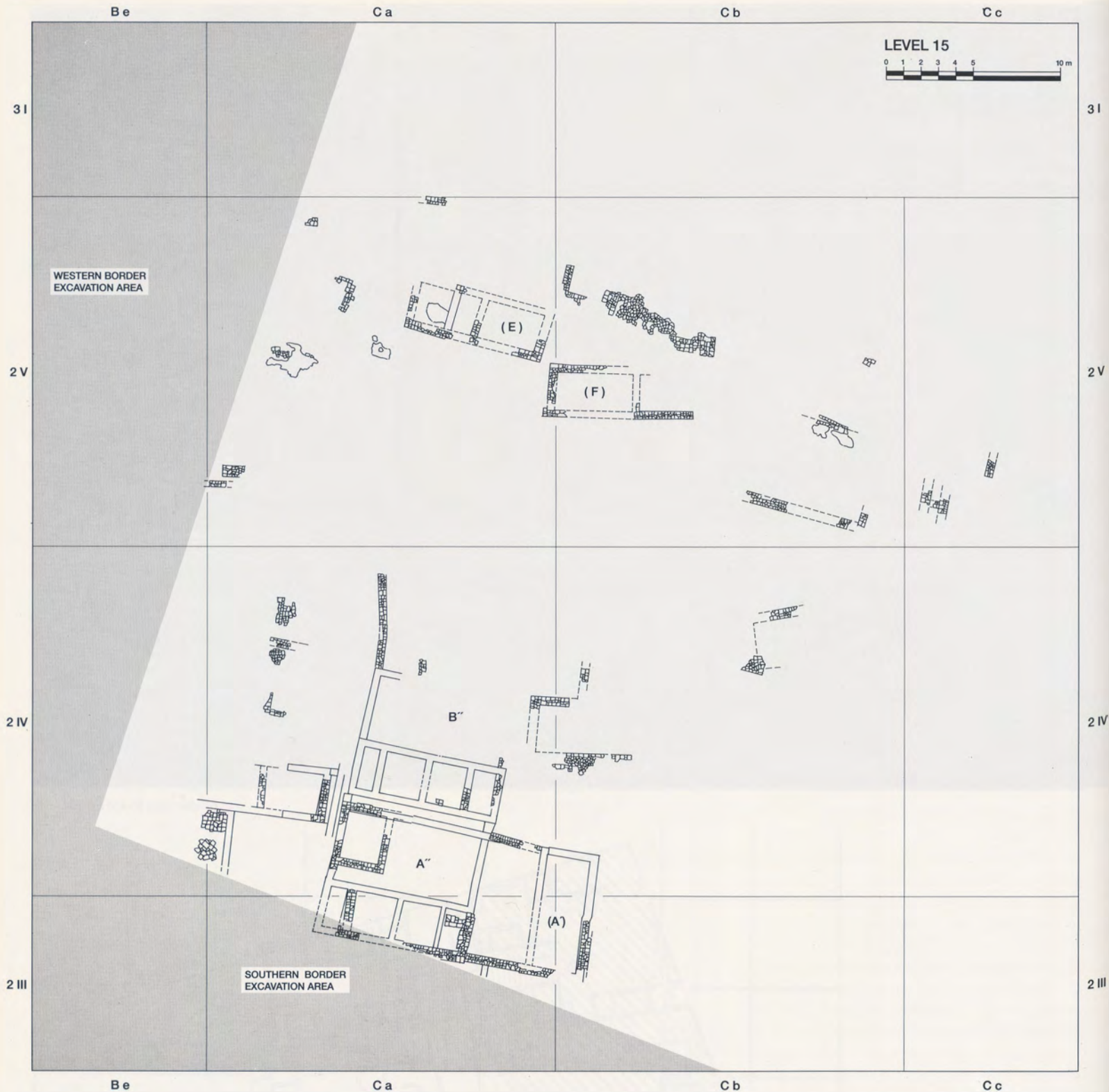

I. THE GUPTA AND POST-GUPTA LEVELS

Level 16 was for a long time to come the last level representing a well-constructed built-up area. From Level 15 up to the levels of medieval times, the mound of Sonkh presented a picture of destruction and decay, leaving nothing but fragments of mostly unconnected walls, thus prevent-

ing a convincing reconstruction of the buildings to which they belonged. It is, therefore, intended to summarize the results of the excavation of these levels. For more detailed information the author refers to an exhaustive description of them in a comprehensive, but still unpublished, report written in German by the architects Wolfgang K. Hecker and Mrs. Gisela Hecker.

Level 15

Level 15 was represented by a number of walls based directly on walls of houses of Level 16 and by remains of newly built structures. This proved valid for the southern as well as for the northern group of buildings. The ground was, as before, ascending from north to south, the height ranging between ca 23.20 and 24.20 m in the north and 24.35–24.80 m in the south.

In case the open space met with in Level 16 was still existing it must have become smaller.

The habitation of the houses A and E, and partly also of B, continued. There are sufficient remains of walls to show that the southern tract of house A was still in use in Level 15. The northwestern room in the courtyard area had been completely rebuilt while the northern, southern and eastern walls of the eastern courtyards were heavily repaired. The newly built and the additional structures were of poor quality due to the frequent use of brickbats and rubble instead of compact bricks. Remains of floor-levels have been exposed at the height of 24.35–24.40 m and 24.50–24.60 m. Of house B, small fragments of walls of the southern row of rooms point to a further use of this tract, but nothing is left of the main courtyard. Fragments of new walls to the east and northeast show that other structures were erected here in the time of Level 15. The same can be said of the long, slightly bent wall in prolongation of the old but now disappeared western wall of house B. The group of small structural remains to the west of the houses A and B, where formerly the buildings C and G were situated, did not show any connections.

In the northern region the southern row of rooms of house E had been partly rebuilt, prolonging hereby the western wing at the point where formerly the curvilinear wall of Level 16 was standing. Nothing was left of the northern tract of this house. Quite different was the situation of house F. The structures found east of house E were completely new and erected farther south than the old building. The direction was now nearly east-west, the exposed length of the house amounting to 8.60 m.

North of house F a mishmash of fragments of walls and brick-pavements came to light on an average height of 23.20–23.40 m. The walls, rising at the highest to 23.58 m, did not permit any reconstruction. Unfortunately this is valid also for all the remains of walls to the east of house F and to the west of house E. Patches of mud-floor have been located in 2 V/Cb at an average height of 23.46 m, those in 2 V/Ca near the western section profile at 24.17 m, indicating the gradient from east towards west.

At the place of the temple platform of Level 16 new structures have been erected using partly the old wall remains as foundations. Remains of a brick-pavement outside the northern wall-fragment made clear that the floor-level around the structure lay at an average height of ca 24.33 m.

Level 15 was, in spite of its disturbed con-



71 Building C of Level 12

dition, the main source of a special type of red slipped jars decorated with bands of black painted horizontal stripes quite different from the mostly stamped Kuṣāṇa pottery and occurring exclusively in the Gupta levels (see e.g. POTTERY, VI.8–19, et passim).

Levels 14 to 12

While Level 15, in spite of its much disturbed condition, could be linked safely with Level 16 due to the continued use of houses founded in Kuṣāṇa times, the situation in the higher levels becomes nearly inextricable in view of the strong signs of destruction caused by conflagration, devastation and decay. The walls and structures unearthed on top of Level 15 were too fragmentary to recognize structural connections. The only method to reconstruct a probable layout of buildings and to allot them to the one or the other level was to arrange the wall-fragments according to their structural similarity, average height, direction, and their fitting together. It is thus possible that more than one phase of habitation is connected with the levels reconstructed in this way, but how ever long they may have been occupied, the accompanying finds of pottery and other objects prove their belonging together.

The remains of walls encountered in the Levels 14 to 12 were, notwithstanding ar-

bitrary deviations, aligned in the same directions, i.e. ESE to WNW. The distribution of structures did not betray any scheme of planning as shown so clearly in the Mitra to Kuṣāṇa levels. The walls were concentrated in the southern area of excavation, with the exception of Level 14 showing incoherent structural remains in the northern region also. The structures, doubtlessly remnants of dwelling houses, were built of brickbats from bricks of different sizes, partly of larger Kuṣāṇa proportions, but mainly of a smaller variety of $27 \times 20 \times 5$ cm to $25 \times 18 \times 5$ cm. The buildings were standing close to each other, sometimes wall to wall and occasionally using the older walls as foundations for the new structure.

Patches of mud-floors showed that the ground was still ascending from east to west and north to south. The floors of Level 14 lay at a height of 24.29–24.39 m in the north, and fluctuated between 24.42 and 24.74 m in the south. For Level 13 the numbers were 24.49–24.77 m in the north and 24.89–25.19 m in the south. Level 12 gave only the northern height of 24.94–25.24 m (Fig. 71).

Besides the typical pottery of the time the most conspicuous finds in these levels were the small and crude grey stone reliefs depicting hinduistic gods and goddesses for domestic worship (see chapter Grey Stone Plaques).



Be Ca Cb Cc

2 III 2 IV 2 V 3 I

WESTERN BORDER EXCAVATION AREA

SOUTHERN BORDER EXCAVATION AREA

LEVEL 14

0 1 2 3 4 5 10 m

The text at the bottom of the page is a vertical column of text, likely a legend or a list of features, but it is mostly illegible due to the image quality and the way the text is oriented. It appears to be a list of items corresponding to the symbols used in the plan.

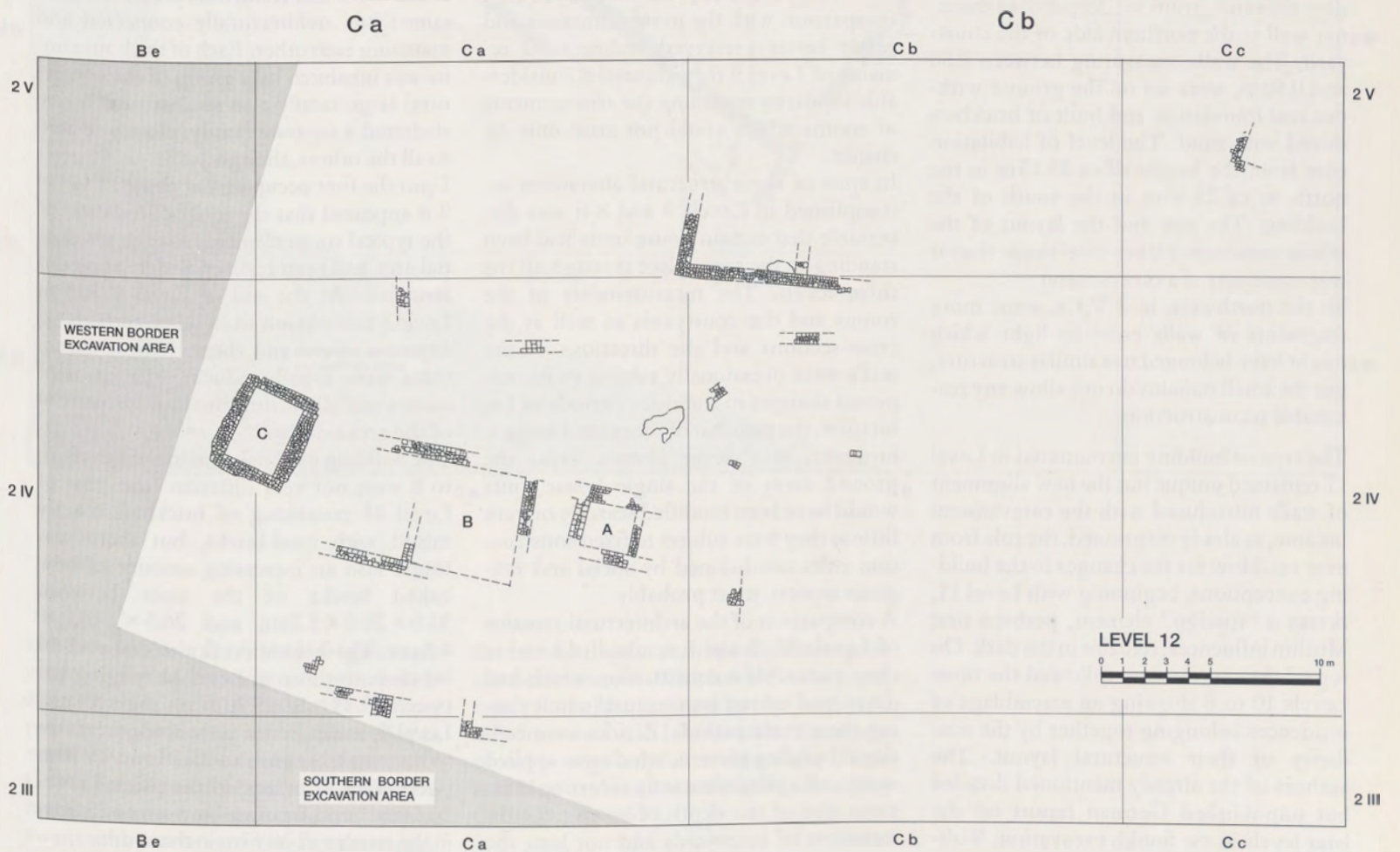
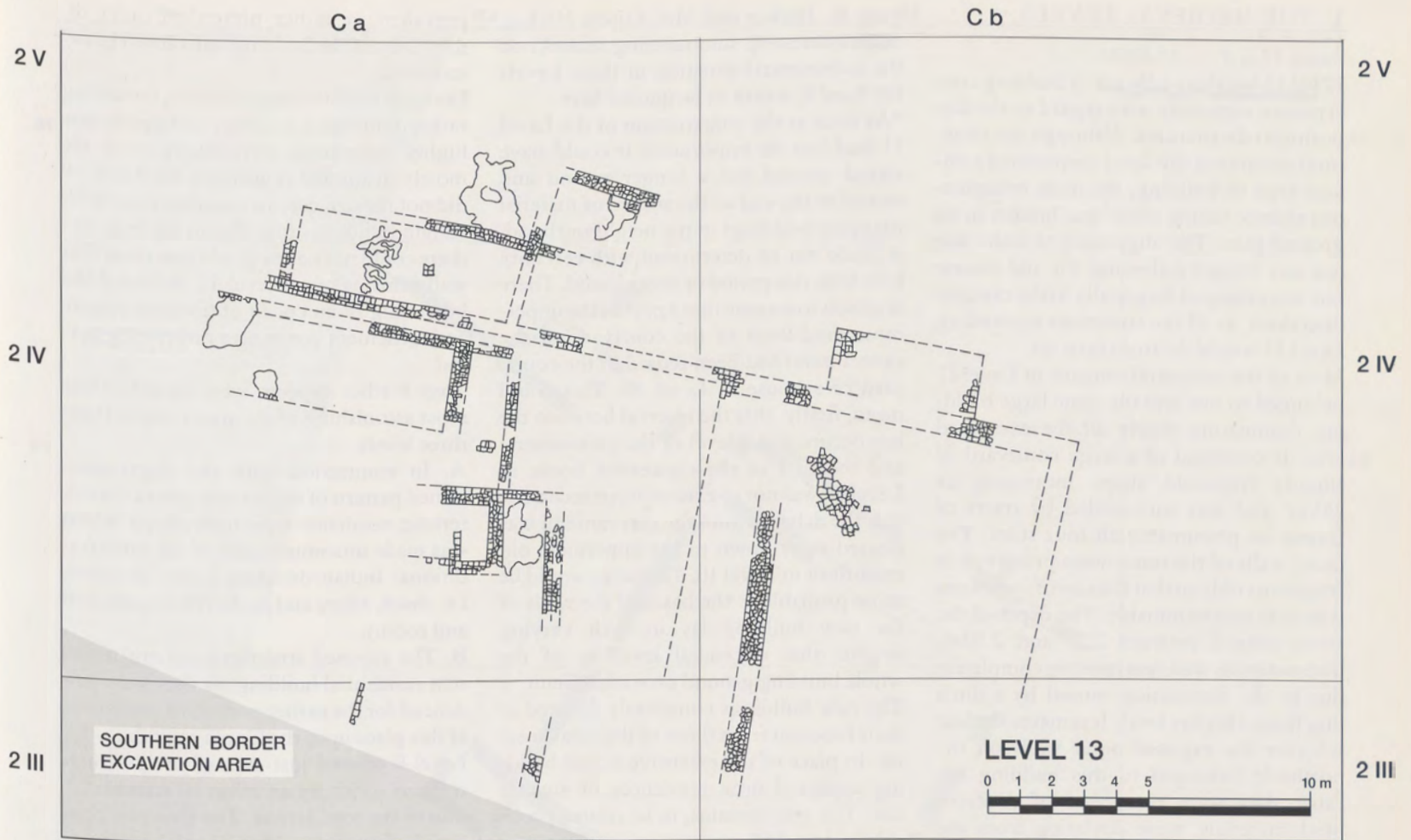

J. THE MEDIEVAL LEVELS

Levels 11 to 8

Level 11 heralds a new era of building conceptions, especially with regard to the disposition of structures. Although the structural remains of this level represented a unique type of building, the most conspicuous change taking place was hidden in its ground-plan: The alignment of walls was not any longer following the old course but was arranged diagonally to the cardinal directions, as all the structures succeeding Level 11 would do from now on.

Most of the structural remains in Level 11 belonged to one and the same large building dominating nearly all the excavated area. It consisted of a large courtyard of slightly trapezoid shape measuring ca 265m² and was surrounded by tracts of rooms on presumably all four sides. The outer walls of the tracts were preserved in fragments only so that the size of the rooms is mostly indeterminable. The depth of the tracts ranged between 2.20 and 2.50m. The outer SE wall was missing completely due to the destruction caused by a ditch dug from a higher level. It remains unclear whether the exposed outer walls on the northside belonged to this building because they were composed of different brick-materials, were deviating from the direction and grounded deeper than the inner wall at the northern side of the courtyard. The walls, measuring between 0.60 and 0.80m, were set on the ground without real foundation and built of brickbats mixed with mud. The level of habitation rose from the height of ca 25.15m in the north to ca 25.60m in the south of the building. The size and the layout of the whole structure makes one think that it was some sort of a caravanserai.

To the northwest, in 2 V/Ca, some more fragments of walls came to light which might have belonged to a similar structure, but the small remains do not allow any reasonable reconstruction.

The type of building encountered in Level 11 remained unique but the new alignment of walls introduced with the caravanserai became, as already mentioned, the rule from now on. How far the changes in the building conceptions, beginning with Level 11, betray a "foreign" element, perhaps first Muslim influences, remains in the dark. On top of the caravanserai followed the three Levels 10 to 8 showing an assemblage of residences belonging together by the similarity of their structural layout. The authors of the already mentioned detailed but unpublished German report on the later levels in the Sonkh excavation, Wolf-

gang K. Hecker and Mrs. Gisela Hecker, made interesting summarizing remarks on the architectural situation in these Levels 10, 9 and 8, worth to be quoted here.

"As soon as the construction of the Level 11 had lost its importance it could have stayed unused for a longer period and served in the end as the source of material for other buildings in the neighbourhood. It could not be determined with certainty how long this period of decay lasted. There is reason to assume that a part of the uppermost mud-floor of the courtyard of the caravanserai had been reused in the courtyard of a house of Level 10. This could mean, firstly, that the interval between the last occupational level of the caravanserai and the first of the concerned house in Level 10 was not so extensive, or secondly, that the debris within the caravanserai was cleared away down to the uppermost old mud-floor in Level 10. The latter would be more probable as the bases of the walls of the new building lay in such varying heights that a general levelling of the whole building ground proved difficult.

The new buildings completely differed in their function from those of the caravanserai. In place of the extensive hostel building appeared now residences of smaller size. The wall-remains, to be related probably to Level 10, were fragmentary, but in comparison with the more numerous and partly better preserved architectural remains of Level 9 they showed a considerable similarity regarding the arrangements of rooms which could not arise only by chance.

In spite of some structural alterations accomplished in Levels 9 and 8 it was discernible that certain house units had been standing in the same place through all the three levels. The measurements of the rooms and the courtyards as well as the cross-sections and the directions of the walls were occasionally subject to incompetent changes in the three periods of habitation, the position of the related houses, however, was never altered. Also the ground areas of the single house units would have been modified scarcely or very little as they were subject to fixed construction rules conditioned by social and religious aspects, most probably.

A comparison of the architectural remains of Levels 10, 9 and 8 resulted in a rather clear picture of a construction which had developed into an architectural whole during these three periods. Besides a conceptual building pattern, which was applied again and again, constantly recurring measures also of the depth of rooms, the dimensions of courtyards and not least the

prevalent or rather prescribed outer dimensions of the building units could be determined.

For such relative late structures, remaining rather unnoticed so long, this result was highly interesting, particularly since the mostly disjointed remains of the Level 10 did not make it easy to correlate them with certain building units. But in the long run there could not be any doubt that these first wall remains after Level 11 indicated the beginning of an epoch of uniform culture and settlement covering a rather long period.

Two further aspects were however the most astonishing of the structures of these three levels:

A. In connection with the above-mentioned pattern of the ground-plan a characteristic residence type took shape which was made unambiguously of the three traditional Indian dwelling house elements, i.e. *chowk*, *tibara* and *kothri* (courtyard, hall and room).

B. The exposed structures did not represent residential buildings as they were evidenced for the earlier periods of settlement at this place upto the Gupta period.

Level 9 offered just enough architectural remains to justify an effort of reconstruction of the total layout. The structure consisted of several residential areas, self-contained but architecturally connected and matching each other. Each of the house units was inhabited by a group of the conjectural large family clan so that each house sheltered a separate family, closely related to all the others, though...

Upto the first occupational phase of Level 9 it appeared that the inner correlation of the typical room elements in each residential area had been realized widely at reconstruction. At the end of Level 9 and in Level 8 this was not so clearly ascertainable anymore. Here and there, built-in structures were found, reducing the space of rooms and distorting the interior pattern of the ground-plan."

The building material used in the Levels 10 to 8 were not very different from that of Level 11 consisting of brickbats mainly mixed with mud-bricks, but there was found also an increasing amount of new baked bricks of the sizes between 32.0 × 20.0 × 5.5 cm and 26.5 × 16.0 × 4.5 cm. The habitation floors of Level 10 lay close to those of Level 11 ranging between 25.45 and 25.70m on the average. Level 9, much better preserved, measures in the north between ca 25.50 and 25.90m (west ca 25.97 m) and in the south 25.60–26.14m. Level 8 ranges between ca 25.80m in the north and 26.17m in the south.



In all these levels the finds of fragmentary grey stone plaques, originating in Levels 14 to 12, continue. The Levels 11 to 9 show pottery types similar to the Post Gupta ware; the more refined pottery of the Early Gupta period has disappeared. Decoration mainly consists of black painted stripes, swans and peacocks, arches and festoons;

the moulded specimens mostly show geometric ornaments. With Level 8 comes up a type of moulded jars and bottles with rich relief decoration in Islamic style. The finds of coins were helpful to date these levels into Medieval and Late Medieval times (see CHRONOLOGY).

K. THE LATE FORTRESS LEVELS

Levels 7 to 1

On top of the related Levels 10 to 8 arose another group of Levels with structures doubtlessly belonging together according to their matching architectural layout. In place of the palatial residences appeared the remains of a homogeneous fortress with strong defence walls provided with a prominent gate to the north and round towers at the corners of which the southeastern one lay in the area of excavation. The fortress developed from a more inaccurate construction in Level 7 to the carefully built citadel of Level 5. Unfortunately, only fragments of the outer walls are preserved, the inner area having been completely destroyed and used again for the structures of Level 4. The architectural development has been summarized in the already mentioned unpublished German report of W. K. Hecker and Mrs. Hecker as follows:

“The built-up and enclosed area of the fortress remained completely unchanged in all the three levels and consequently the outer walls of Level 7 existed further also in Level 5 as did the corner bastions shaped as round towers. First changes took place in Level 6 when the northern inner wall, running parallel to the thicker outer wall in a maximum distance of 0.50m, was given up and replaced through wall lines further inside the fortress. These alterations resulted in narrow corridor-like flights which were apparently subdivided by cross-walls in different intervalls forming rows of rooms. This arrangement was maintained fundamentally in Level 5 as well, though with enlarged depth of rooms.

The position of the entrance gate at the northside of the fortress remained the same through all the three levels. Only the gate towers were removed in Level 5 about 4.00 metres northeastwards... The extension of the porch in SW-NE direction must have amounted to at least the double of the earlier measurement through it (Fig. 72).

The fortress must have been completely rectangular as could be recognized from the eastern corner of the construction. It had an axial position which deviated from the northern direction by 25° towards east. The chronological subdivision of the wall-remains of the three levels encountered partly with fundamental difficulties because these three building periods followed one another mostly without any recognizable interruption. This was the case specially with the outer wall although it had possibly phases of reconstruction to show ...



72 Remains of fortress porch with earlier tower under left wing

The northern outer wall including the northeastern tower as well as the whole alignment of the eastern wall of the fortress were therefore traced in the plan only for the Level 5 as the excavated walls represented the preserved parts of the last building phase (Figs. 73,74). In the plans of the Levels 7 and 6, only dotted contour lines were registered for these walls, which marked them as reconstructed, in this special case older, building components.

The matter was different with the architectural remains of the gate area and some reconstructions near to the outer wall which appeared in the respective plans, so far as they were to be dated...

The building material of all the preserved wall remains of the Levels 7 to 5 consisted

entirely of baked bricks. Clues for the use of mud-bricks were present only at one place in Level 7. The share of undamaged baked bricks was however not very large. However, very different sizes have been used during the construction as was shown by the measurements of the complete bricks. The following is a list of the sizes noted down:

23.0 × 17.5 × 4.5 cm
 25.0 × 15.5 × 4.5 cm
 26.0 × 16.0 × 4.5 cm
 28.0 × 16.5 × 5.0 cm
 29.0 × 20.0 × 5.0 cm
 29.0 × 25.0 × 6.5 cm
 31.0 × 20.5 × 6.5 cm
 39.0 × 26.0 × 8.0 cm

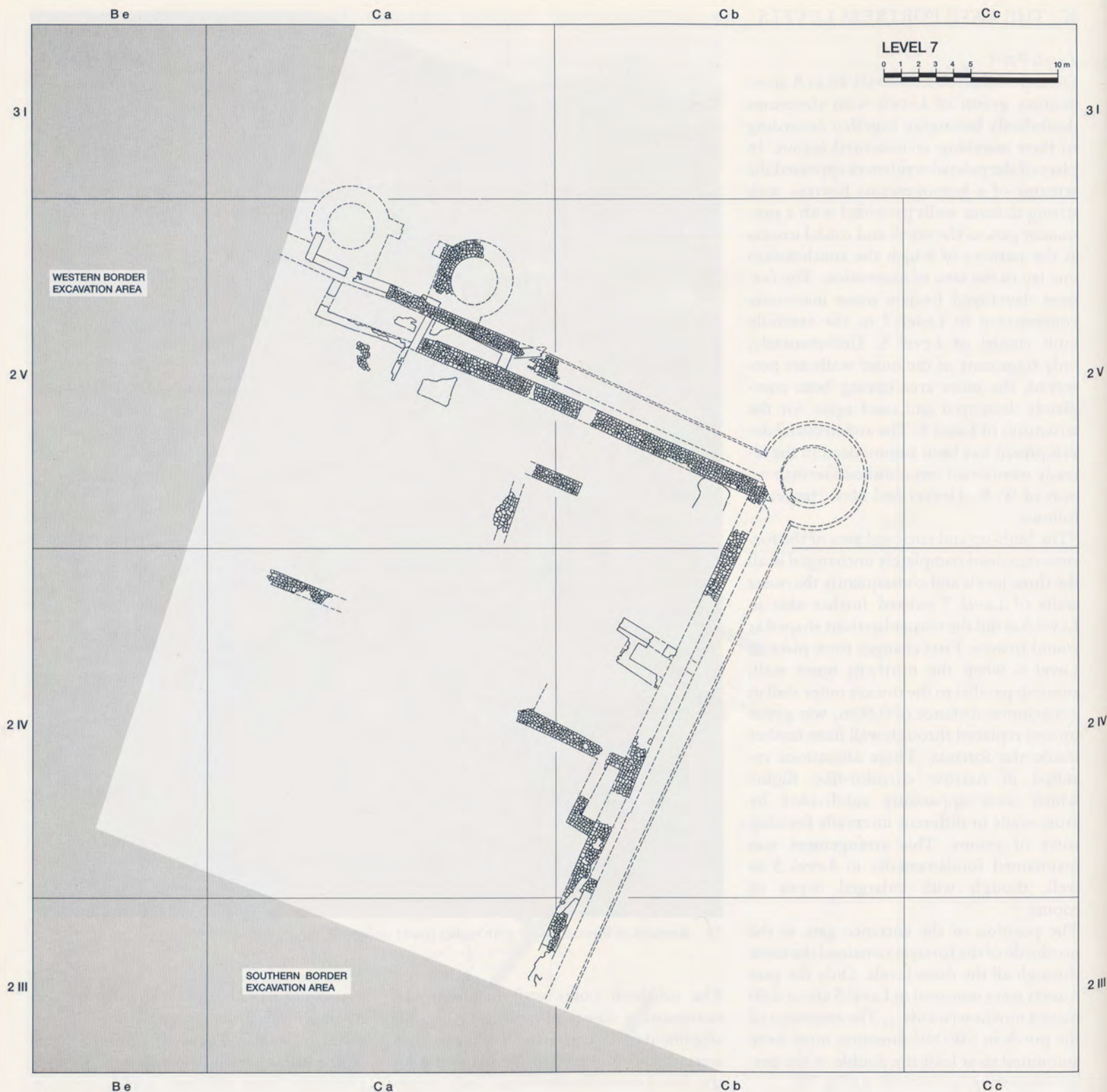

As for the habitational niveaus of the three fortress levels, only very few and very general statements on the eventual height are possible on account of the very scanty floor-remains. As in Level 4, the whole interior of the old fortress was disturbed completely whereby almost all the inner walls of Levels 7 to 5 must have been pulled down up to the fundamental layers, neither the habitational levels nor the

ground plan conception of the interior of the fortress could be ascertained... Within the three levels the floor remains seemed to indicate a difference of elevation of about 0.30 or 0.20 m, from the one to the next younger level.⁴

In fact, the ground levels did only slightly surpass that of Level 8. The small patches of floor preserved here and there measure in the north of Level 7 ca 25.65–25.86 m,

in the north of Level 6 ca 25.65–25.81 m and little more south ca 26.07–26.21 m. In Level 5 the highest patches of floor were exposed at ca 26.07–26.14 m in the north and ca 26.26–26.32 m towards south.

The measures of the main walls were registered as follows: The northern double wall in the early Level 7 measured altogether 2.80–2.90 m in section with varying thickness of the single walls between 0.80 and

1.00 m, including the eastern wall with its averagely 0.97 m. A fragment of the eastern gate tower permits to calculate the outer diameter of these towers as 4.50 m, the inner one as 2.60 m, leaving 0.95 m for the tower wall. The diameter of the north-east bastion did apparently not differ from that of the tower in Level 5. Here the outer walls of the fortress varied in thickness between 1.12 and 1.20 m. The prolonged porch was 3.50 m broad and presumably 6.60 m long. Although only a small wall fragment of the western gate tower was preserved, it is very probable that the size of these towers were matching the old ones in Levels 7 and 6 with their outer diameter of 4.50 m. The north-eastern bastion shaped as a completely circular tower had a diameter of 5.90 m and a thickness of the wall of 1.20 m. It was preserved to a height of 3.40 m, founded at 24.40 m. The inner wall parallel to the eastern front line had a thickness of averagely 0.80 m, bordering the row of rooms showing a depth of ca 2.20 m.

Of great importance was the find of altogether seven iron cannon-balls with an average diameter of 16.8 cm and a weight of ca 19.1 kg. At two places of the outer eastern wall there were damages which were undoubtedly caused by these balls, one of them still sticking in the wall (see METAL OBJECTS, no. 127).

With Level 4 begins the last constructional phase of the citadel at Sonkh representing a large building block surrounded by strong ramparts of mud giving the construction the character of fortified residences. From here the huge moat around the citadel elevation has been dug reaching down partly to the PGW-levels or even to the natural soil destroying in its course large areas of valuable cultural ground. The situation has been described in the above-mentioned detailed but unpublished German report on the late levels at Sonkh by W. K. Hecker and Mrs. G. Hecker from which a summarizing passage may be quoted here.

“After dismantling the fort of Level 5, the subsequent owners of the mound of Sonkh erected their new buildings with only slight differences of height on top of the preceding construction and almost directly on the old wall-stumps without using them as base even partly. Most probably an intensive disposal of the debris, mainly in the interior of the fort, took place before the beginning of the new construction, destroying thereby the remains of buildings from Level 5 for the most part, because floor-remains in the older fort could be met with only scantily. The habitation level of the



73 Fortress walls, Levels 7 to 5, and North-east tower, Level 5



74 Eastern fortress wall. Level 5

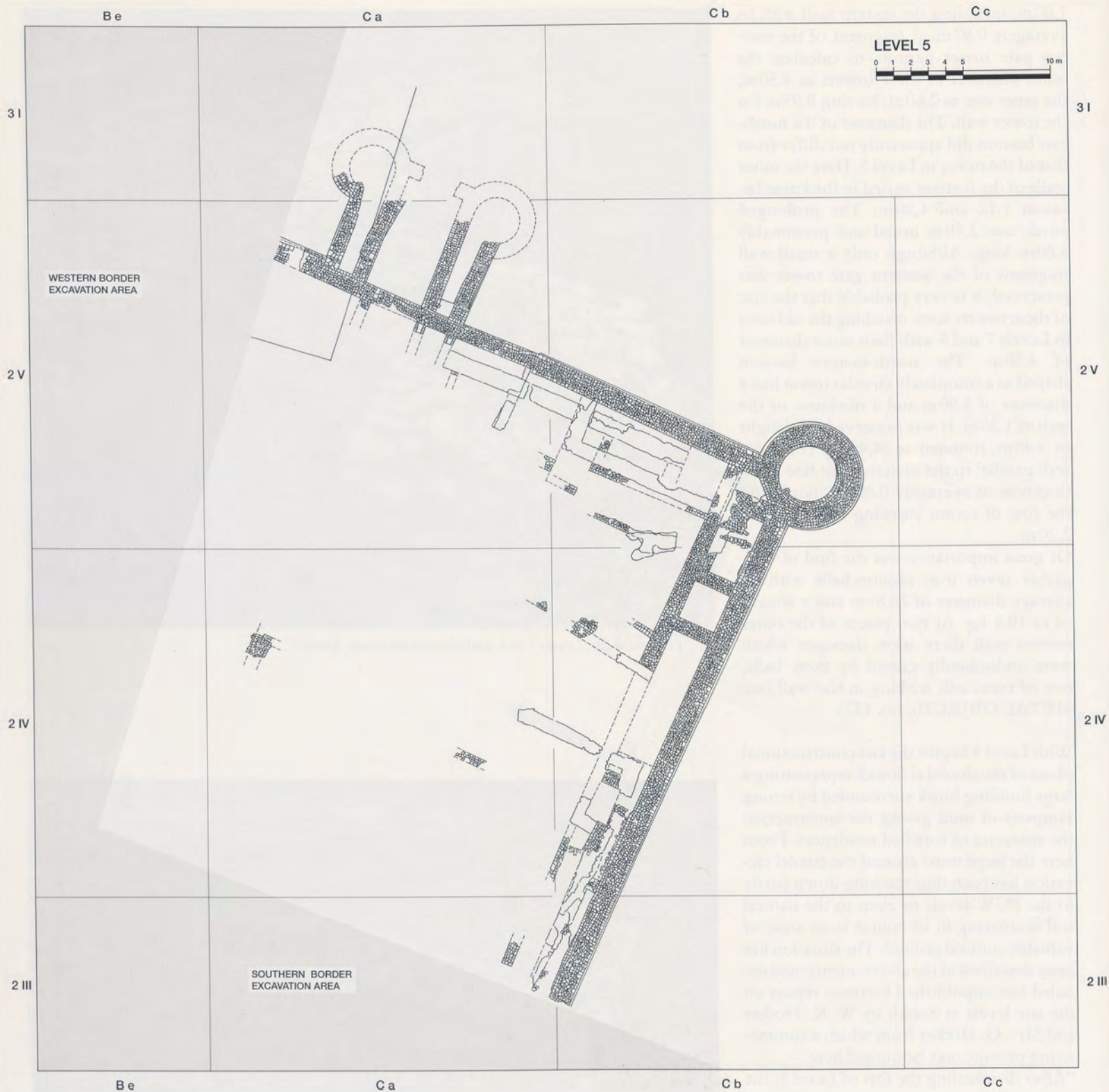

first phase of the citadel from Level 4 must accordingly have reached down to the old floor region. The buildings which arose on the mound, grown up already considerably through centuries of habitation, indicated only an unimportant change of direction to the previous construction. Indeed, the strong fortress walls of the structures of the three preceding levels gave the mound already a conspicuous and characteristic

shape, an alteration of which would have entailed a lot of structural difficulties. No remarkable deviation was also to be recorded regarding the housing space in Level 4. The expansions amounted to about 1.00 up to maximum 2.20m in both the directions within the excavated area. That the new construction, in spite of its obvious civil character, possessed likewise a military trait was shown by the even more

strongly built corner bastion, present also here, and a rampart all around, executed in immense sizes in the last building phase finally, whose effect of elevation was yet enhanced optically by a *deep and wide moat* – a moat which did not carry water always but only held the rain and flood water during the monsoon...

Despite these certain relations with the old fortress the construction of Level 4 repre-



sented a new conception with important deviations and alterations in comparison to the buildings of the preceding three levels. Already the whole outer appearance was completely different:

A. The old fortress stood with its walls of rather dark red baked bricks vertically on the hill side, the high rampart of the fort from Level 4, on the contrary, had in all of its building phases a sloping shape

and was composed of grey mud. The building walls were not at all visible outside as they remained concealed deep behind this rampart.

B. The corner towers had a rounded shape but not a circular one anymore and possessed much bigger measures than the old ones. Moreover, they were built, as the outer rampart, only of earth and mud.

C. The forts from Levels 7 to 5 had their

straight-lined approach leading upwards to the gate at the northern side and one could enter the interior without changing the direction of walk. In Level 4 the entrance was removed to the eastern side and a hook-shaped type of double gate was chosen, an architectural peculiarity of the late Muslim fortress structures. . . .

D. Besides some structures on the corner tower, almost the whole construction of



75 Pilasters of mud along the fortress rampart. Level 4

Level 5 was erected exclusively of baked bricks, whereas for the buildings of the residential castle of Level 4 sun-dried mud-bricks were used predominantly. Only in special cases baked bricks together with weather-resisting plaster or the like were applied.

A special deviation in the method of building became evident at the outer walls of the buildings behind the rampart. Their outer sides had no high, free-standing facades but were set exclusively in the rampart ma-

terial heaped up before. It could not be ascertained whether there existed differences also regarding the room conception in the interior of the fort, specially between the constructions of Level 5 and 4, because the much too few remains of the older fortress did not allow enough parallels.

The protective belt of Level 4 showed several construction phases which could be assigned to the two main building periods I and II. The first phase differed from the later phase II, extended far wider, not only regarding the lower height and thickness of the rampart and tower structures but also regarding several phases of repair not to be ascertained with the phase II. Thus besides the original phase Ia at the exposed parts of the north and the east ramparts two extending phases of reconstruction (Ib and Ic) could be discovered while at the northeastern tower, besides the phase Ia, only one reinforcing phase of repair (Ib) with appropriate flooring level was recognizable.

Presumably in the latest phase of Level 4 the facade of the ramparts and tower was astonishingly decorated with pilasters of mud of which only the stumps could be exposed. Often they measured only a few centimetres, but occasionally stood up to somewhat over 1.00 m high.

“It could not be explained with certainty whether this architectural peculiarity arose already in Level 4 by the construction of phase II and was planned as facade element from the very beginning, because the pi-

lasters were not erected simultaneously with the building of the rampart and tower. They were however drawn in the survey plan of the last habitational phase of the castle from Level 4.

The half-columns of mud were not embedded in the mass of earth of the rampart or tower, or not built-up even with them together, as already mentioned. They were first placed against the coated outer surface; the joints between the pilasters and the outer skin were clearly discernible everywhere. The width of the pilasters measured between 0.60 and 0.95 m at the base, the depth 0.50 m averagely (Fig. 75). In accordance with their gradients the pilasters could not have been led up to the crown of the rampart but had certainly a height of a few metres only.

The eastern rampart showed ten such half-columns, the centre distances varied between 2.25 and 4.00 m. The tower had originally 18 pilasters of which 14 could be found still, although their remains stood only a few centimetres high; the centre distances measured here lay between 1.65 and 4.30 m. At the northern rampart 8 pilasters could be exposed with centre distances between 1.45 and 2.20 m.”

Within the buildings were encountered several habitational phases which were indicated through built-in structures and alterations, renovations and elevations of floors, additions of passages and alterations of elements of wall decorations and the like.

“The buildings exposed within the excavation area consisted of two self-contained blocks lying side by side, but without a common wall, in east-west direction, having nearly equal areal and conception of room. Their separate entrances lay at their southern side where there was a big yard or square which came up to the gate section at the eastside of the fort (Figs. 76–79).

The two building units were meant evidently for families of about the same rank whose members were close relatives. The conception of both the house blocks showed some things in common:

1. An almost square inner yard formed the centre.
2. As mentioned already, the entrance was situated at the southside.
3. No view into the courtyard was possible from the door of the house because of staggered doors in the entrance part, which demanded from the incomers to change the walking direction several times.
4. The residential and domestic rooms surrounded the inner courtyard on all four sides.



76 Courtyard of Residential Quarter 1, Level 4

5. In none of the walls surrounding the inner courtyard there were doors for closing; the neighbouring rooms were to be entered all through three to five open passageways separated from one another by pillars only. Rolled-up mats or curtains ought to have made up for the doors as was the rule with the Indian palace buildings.

6. The drainage of the roofs occurred through diversions into the inner yard and from there on the main yard through the southern group of rooms.

7. Both the houses were rebuilt in later time and extended towards the south moreover."

"The built-up area of the eastern residence covered a space of 420 m² during the first habitation phase. The dimensions of the north and the south side amounted to 18.50 m and 18.85 m, those of the west and east side 22.50 m each. During the later extension towards south, the inhabited space enlarged to ca 463 m².

The second residential quarter (west) was only slightly larger. The total length of the east-west dimension must have amounted to approximately 18.60 m, that of the north-south dimension measured, during the earliest time of occupation, 24.95 m at the westside and 25.95 m at the eastside. This resulted in a built-up area of almost 467 m². After the erection of an additional row of rooms in the south and an extension of this tract eastwards close to the first residential quarter the building enlarged to over 528 m²."

In the courtyards and rooms of the residences were located several floors following one above the other from the beginning of phase I to the end of phase II. The height of the floor-levels of the eastern building differed slightly from that of the western one. In the residential quarter 1 (east) the courtyard floors lay at a height between 26.64 and 26.86 m, in the various rooms they ranged between 26.67 and 27.12 m. Residential quarter 2 (west) had the courtyard floors at 26.38–26.53 m and the room floors between 26.50 and 26.83 m.

The modest remains of structures following above in the Levels 3 to 1 depended in their layout on the construction of Level 4. Level 3, palpable only in the region of the old western residence, was recognizable by its careless building work, by built-in mud walls and the partial breaking off of the separating wall to the eastern residence. The floors were located at the height of 27.02–27.30 m averagely. Stronger even were the alterations in Level 2 leaving as much as nothing of the former western re-



77 Partition wall between the two Residential Quarters in Level 4



78 Courtyard and pilasters of Residential Quarter 2, Level 4



79 View of rooms in Residential Quarter 2, Level 4

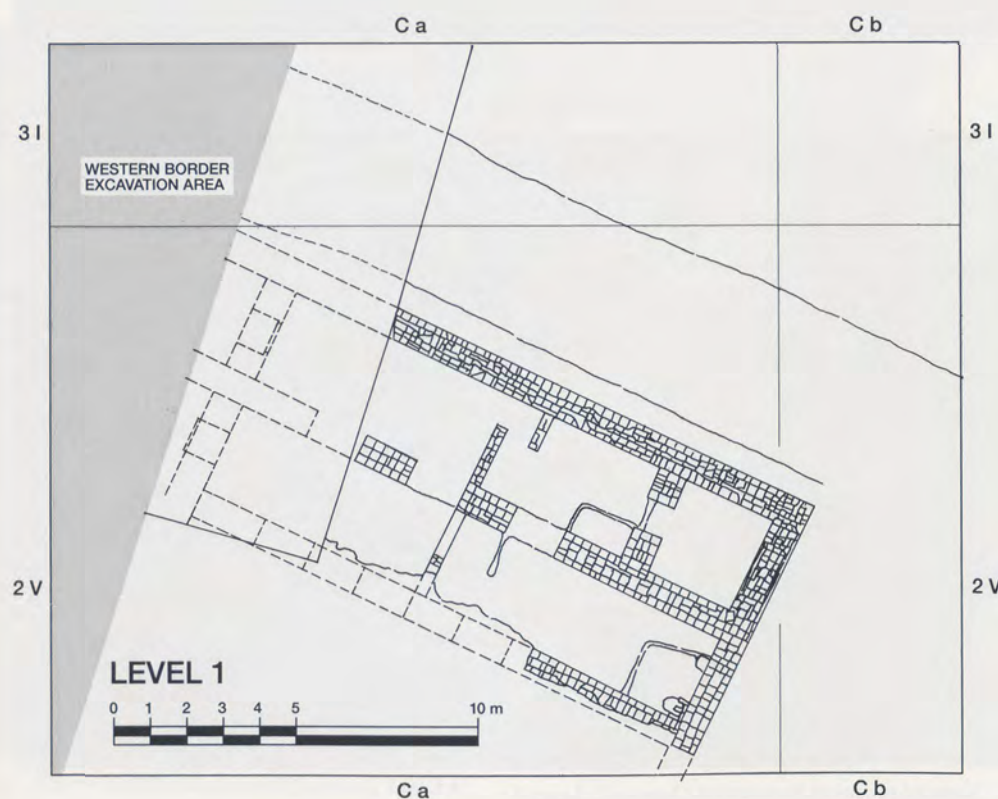
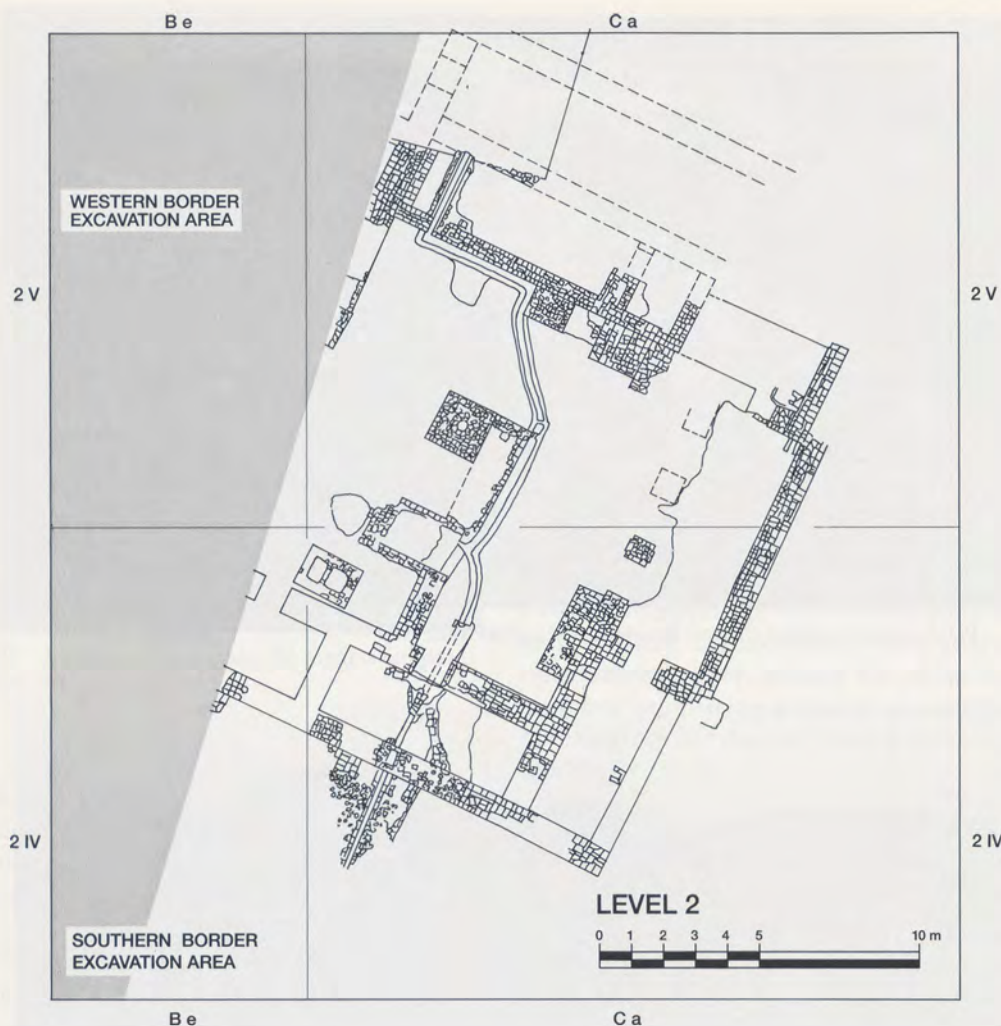

sidential quarter with the exception of the outer boundary. The room-tracts around the courtyard were for the most part removed, at the northern border of the new greater yard a 1.00 m wide staircase leading upwards was erected of baked bricks. Conspicuous was a branching drainage system consisting of slightly curved mortar-plastered gullies and smaller as well as larger water basins. The building material was generally composed of brickbats now. The floor lay between 27.16 and 27.48 m, the terrace had its level at 27.95–28.05 m.

The eastern residential quarter does not seem to have endured such phases of reconstruction. It rather looked as if the whole quarter had soon been filled up and not been used for new constructions anymore.

The remains of Level 1 situated above the former western residential quarter showed a northern tract similarly arranged as that in the old building. The northern wall has been moved slightly outwards and was built of mud-bricks like all the other walls. This outer wall was not leaning against the rampart but had been carefully erected vertically showing a clean wall space. The floors of this level lay at the height of 28.34 and 28.61 m. The rampart of Level 4 was still existing but just as a survival of older times.

How and why the latest residences had been abandoned could be explained neither by the condition of the structural remains nor by other indications. There are no signs of a hasty desertion nor of destruction by warlike actions. Remarkable is the fact that with the exception of a greater number of well preserved vessels of all sizes left on the floors and fragments of latest terracotta animals almost no utensils of daily use were found. The excavated buildings gave the impression of having been carefully cleared out, as if by a well conceived plan.

III. CHRONOLOGY

Period I. According to the stratigraphic data discussed above the accumulation of earth, on average 1.00m thick, containing Painted Grey Ware as well as Black and Red Ware sherds could be subdivided into four levels numbered 40 to 37. In all trenches where these wares were encountered they rested right on the natural soil. The surface height of this soil in diverse places gives an indication of the range of the earliest settlement area at Sonkh. In the north (Trench 1) it measures between 14.25 and 14.50m. The more western Trench 3 gives a height between 14.00 and 15.00m (situated partly in ground water, perhaps sloped). In the southwestern Trench 4 the natural soil was reached at 15.50 to 15.75m and in the small southeastern Trench 2 at a height of 15.30m.

The comparable data for the upper edge of the compact pile of PGW and BRW soil are: Trench 1 = 15.40–15.50m; Trench 3 = 16.40m; Trench 4 = 16.45m; Trench 2 = 16.30m. As mentioned in the stratigraphic report above three radiocarbon data help to determine the age of the levels of the PGW Period I at Sonkh. The earliest charcoal sample was taken at a height of 14.80m in 3 I 11.5/Ca 14.2 (Trench 1), situated in Level 39. Its date is 2645 ± 90 cal BP = 695 cal BC. The second sample came from 2 IV 8.45/Be 17.5 at a height of 15.40m corresponding to Level 37 and resulting in a date of 2598 ± 140 cal BP = 648 cal BC. The third sample had been gathered from a conflagration layer immediately above the sloping PGW pile of earth at 14.77m in 2 IV 15.95/Cc 2.30, i.e. the northeastern cutting, giving a date of 2454 ± 124 cal BP = 504 cal BC. As no charcoal material was found in the earliest PGW-Level 40 one has to concede some space of time for it. But even at a generously hypothetical assumption up to one hundred years one does not come to any time older than ca 800 BC for the beginning of the Painted Grey Ware settlement at the old Sonkh.

Period II. Directly above the last PGW-Level 37 follow, externally indicated by a stupendous change in the colour of earth from yellowish to grey, the first mud-structures and finds of a cultural context very different from the one before. In any case, the presence of PGW and BRW sherds ceases abruptly in Level 36. Following the appearance of different pottery shapes of the Associated Ware the first sherds of the Northern Black Polished Ware (NBPW) were found. Along with them typical Mauryan terracotta figurines and unscripted

cast and die-struck coins (COINS, nos. 1–5) as well as a silver punch-marked coin (no. 49) have been recovered.

Period II extends up to Level 29, including the levels of the Śuṅga Cultural Phase (Level 32–30) and the first level of transition (Level 29). The unusual term Śuṅga Cultural Phase, abbreviated in the description of objects as Śuṅga C. P., has to be understood as an expression of reasonable doubt whether the Śuṅgas ever ruled over the State of Mathura. But the term implies that the find material, especially terracotta figurines, found above Level 33 up to Level 30, definitely proves to be different regarding shape and style from the preceding specimens, and represents what usually is classified as “Śuṅga”. The stylistical and iconographical development of the terracotta materials, so conspicuous in Period II, is discussed in the respective chapters. Special attention needs the first appearance of a terracotta *plaque* among all the free-standing types.

Most important are the finds of coins found along with the terracotta objects of the Levels 32 to 30, consisting of unscripted die-struck specimens, showing a lion before Indradhvaja symbol (COINS, nos. 4–6), and punch-marked copper and silver coins (nos. 7–49) which were still the currency with the largest circulation.

For the Levels 30 and 29, the complete absence of the free-standing grey terracotta female figures found in the previous layers is typical. Although females remain the favourite subject, the domestic art is now characterized by moulded terracotta plaques. The style of the figures depicted is still akin to that of the Śuṅga Cultural Phase. The pottery has hardly changed in design.

With Level 29 the manner of constructing buildings changed conspicuously. While from Level 36 to 30 all buildings were erected of mud walls, the structures of the Levels 29 and 28 were for the first time built of mud-bricks. This change heralded the end of the Śuṅga Cultural Phase and marked the transition to the period of the Local States of Northern India, here the State of Mathura under the dynasty of the Mitra rulers, towards the end of the second century BC. To this period of transition belong two unusual die-struck copper coins (COINS, nos. 52–53), one showing a standing human figure before bull on the obverse and the Ujjain symbol on the reverse, the other with an indistinct obverse, but again the Ujjain symbol on the reverse.

Period III. At first sight, Level 28 appeared to offer little changes because the potteries

were almost the same and no alterations were actually to be registered in the building methods as revealed by the few remains of houses in comparison with those of Level 29. Only the terracotta plaques showed signs of an emancipation as if they wanted to establish an off-from-the-Śuṅga movement. Conspicuous is the increasing number of fragments of votive tanks as implements for the domestic *pūjā* and the first appearance of terracotta seals and sealings showing symbols or names inscribed in Brāhmī. The beginning of a new era, however, became evident by the find of two special coins, being the first inscribed coins from Sonkh. Their reading runs *gomitasa* (COINS, nos. 54–55), thus proving that they were issued by Gomitra, the first of the Mitra rulers of Mathura. These two specimens were discovered at completely different spots in 3 I/Ca and 2 IV/Cc wide apart from each other, but definitely in the same level. The clear succession of coins in the subsequent levels proved that the Gomitra coins are rightly ascribed to Level 28. According to the finds and their structural context Gomitra seems to have ruled for a short time only; already in Level 27 Sūryamitra follows as the next of the Mitra rulers of Mathura. This Level 27 is the one with the first group of buildings mentioned above as having been built of baked bricks. Not less than eight clearly identifiable and legible Sūryamitra coins of the standard type (COINS, nos. 56–60d) as well as ten utterly small 1/8 Kārṣāpaṇa coins of this Sūryamitra level (nos. 61–65d and introductory remarks in COINS) were found in the streets and houses of this most extensively excavated level and also in the lower phase of Level 26. The solidity and comfort of structures as well as the abundance of finds create the impression of a great prosperity; it seems that Sūryamitra had not only been the most important but also the Mitra king with the longest reign. A charcoal sample collected in Level 27 (3 I/Ca) at a height of 18.40m resulted in a carbon age of 2171 ± 108 cal BP = 221 cal BC, being no doubt a bit too early.

The succession of coins continues on top of the Sūryamitra level; five coins of Brahnamitra (nos. 66–70) and two of Viṣṇumitra (nos. 71–72) follow in the upper phase of Level 26 and in Level 25. Nowhere between Level 28 to 25 Mitra coins occurred in a mix-up. Therefore, the conclusion may be drawn that, at the time of the Mitra kings, the circulating coins used to lose their validity with the death of the ruler. The find situation leaves no doubt that the succession of the Mitra rulers of Mathura is herewith established as Gomitra – Sū-

ryamitra – Brahmamitra – Viṣṇumitra beginning at the end of the second century BC and extending over most of the first century BC. As to Dr̥ḍhamitra, not present at Sonkh, see Härtel, 1986, p. 105.

The placing of Gomitra into a phase subsequent to the middle Śuṅga period in the Puranic lists can hardly be doubted. It is more difficult to determine the length of the reign for the successive rulers. It would be unrealistic and incompatible with all excavation experiences to assume a substantially longer period than twenty years for the individual levels. Moreover, the group of Mitra levels is embedded in an uninterrupted sequence of building activities. In fact, no more Mitra coins appeared in Level 24, the first Kṣatrapa level.

One may hope for an archaeological establishment of that succession of coins in other Local States of Northern India. It is, of course, quite possible that one or the other Local State may have been founded somewhat earlier than that of Mathura, but the disintegration of the Śuṅga Kingdom, if playing a role at all, began most probably in the last third of the second century BC.

Period IV. Levels 24 and 23 belong to the time of the Kṣatrapas of Mathura. The earliest Kṣatrapa coins recovered near to Level 25 were two specimens of Hagāmaṣa (COINS, nos. 73–74) and one of the Rāja Rāmadatta (no. 75). Immediately above, in the Levels 24 and 23, fourteen more Kṣatrapa coins were unearthed within the houses and on the roads. One of them is a Mathura issue of Rājuvula (no. 79), but the bulk hails from Śoḍāsa (nos. 80–81 and *Note*). Besides, three more Rāmadatta specimens were found within the same levels (nos. 76–78). It seems as if the rule of the Kṣatrapas overlapped the reign of Rāmadatta. Noteworthy is that only Rāmadatta coins were detected and none of the other numerous -dattas. The outcome of the Sonkh excavation raises the question whether the dynasty of the Dattas can be considered as a continuous one of fifteen rulers in succession. Or will it not be more probable that most of the Dattas ruled concurrently in small subdistricts of Mathura and the surrounding area and that the period of their reign extended over a few decades only? It would be interesting to know which Datta coins were found in other parts of the Mathura district and the neighbouring states. D. C. Sircar's (1953, p. 171) dating of the Dattas subsequent to that of the Kṣatrapas, i.e. into the Kuṣāṇa time, could not be confirmed at Sonkh contrary to his quite acceptable date for the Mitras.

The occurrence of an element of a different culture within Level 23 has already been observed when dealing with the building activities in this Period IV. In Level 23, for instance, the roof construction and the layout of the houses underwent considerable changes. The shape of pottery, as found in Levels 26 and 25, was replaced by new types of earthenware. Yet it cannot be overlooked that, along with the independent ceramics of Level 23, the first examples of stamped "Kuṣāṇa" pottery appear.

Among the finds, the numerous figures of a particular type of Mother Goddesses (TERR.HUM.FIG., nos. 79 ff.) attracted attention. No figure representing Kubera and Skanda had been found so far. This was all the more astonishing, for in Level 21 the cult of these gods was already quite common. In this connection a seal-impression may be mentioned bearing the name *Anaṅgabala* in two scripts, i.e. in Brāhmī and Kharoṣṭhī, which throws some light on the eclectic nature of that culture.

Naturally, no absolute date can be given also for the Kṣatrapa levels. But there is no doubt that the Kṣatrapa houses were built directly upon the last Mitra structures. The sequence of levels requires for Hagāmaṣa, whose two coins were unearthed below that of Rājuvula, a date in the end of the first century BC. Even without any attempt to date Rājuvula and Śoḍāsa, it is evident that at Sonkh their reign reaches into the first century of the Christian era.

Period V. The Levels 22 to 16 are all belonging to the Kuṣāṇa time. Level 22 was built directly on the worn-out structures of Level 23 in its late phase. While this level takes over in its transitional stage the size of bricks from the preceding Level 23 (cp. SOME STRUCT.OBJ.), the houses of the Levels 21 to 16 were generally built of bricks of the usual Kuṣāṇa size of 37 × 23 × 5 cm. The advent of the Kuṣāṇa times was best documented in the overwhelming mass of stamped Kuṣāṇa potteries accompanied by diverse finds of terracotta objects, especially figurines, of stone sculptures, metal images and objects, and a good number of stamps with names incised in Kuṣāṇa Brāhmī. The earliest coins are those of Wima Kadphises/Kaniṣka I (COINS, nos. 83–87) followed by such of Huviṣka. A pot with 120 copper coins found in a house of Level 16 contained mainly issues of Vāsudeva I and his successors (nos. 93–106). An interesting find was a crossbar from a stone railing found in the filling material of Level 19, i.e. belonging to Level 18, bearing an inscription dated into the time of Mahārāja Kaniṣka (I) but

used as rubbish already a few decades after his reign (OTHER INSCR.OBJ., no. 6). Not all of the Kuṣāṇa levels are equally well preserved. Layers of ashes and other residues indicate that the one or the other structure was destroyed by force. Quite often, the older building materials were reused for a new construction. The classification of the individual levels is facilitated by the circumstance that most of them were rebuilt according to a fixed plan, after the older area was filled up and levelled. Every now and then, the rows of walls in the new structures coincided with those of the preceding ones, since the approximately north-western direction of building was adhered to throughout the Kuṣāṇa settlement in Sonkh; the old walls could, therefore, be reused as foundations. Where the building plan differed, new foundations were laid without any consideration of the older constructions, quite often cutting through the old brickwork. Only one particular building remained in one and the same place: the structure marked as Apsidal Temple 1 on the open space in 2 IV/Cb. This structure was rebuilt, extended and overbuilt again and again through all the Kuṣāṇa habitation periods (see H. APSIDAL TEMPLE NO. 1).

Judging from the succession of structures with its distinct floor-levels, the stages of reconstruction of the temple and the species as well as the position of relevant finds, the altogether seven Kuṣāṇa levels may tentatively be ascribed as follows:

Level 22–20 = Kaniṣka I

Level 19–17 = Huviṣka

Level 16 = Vāsudeva I and Successors

Level 19 yielded a charcoal sample collected in 3 I/Ca which resulted in a carbon age of 1935 ± 103 cal BP = 15 cal AD.

Periods VI to VIII. Level 16 was the last level with extensively preserved structures representing a built-up area. Above Level 16 the mound of Sonkh presents a picture of destruction and decay leaving nothing but fragments of mostly unconnected walls. The attribution of the fragmentary structural remains to distinct levels and the location of level-floors was, consequently, very difficult. The only method to reconstruct a possible layout of buildings and to allot them to the one or the other level was to arrange the wall-fragments according to their structural similarity, average height, direction, their fitting together, and the general levelling of the area under consideration of possible gradients. It is thus possible that more than one phase of occupation was connected with the levels reconstructed in this way.

Level 15/14 is by its structural connection with Level 16 and by the finds of definite Gupta materials, like the fragment of a terracotta relief with the depiction of a Makara as *vāhana* of goddess Gaṅgā (TERR. HUM.FIG., no. 186), the characteristic Gupta sherds decorated with marvellously moulded designs (DECO.POT., nos. 159–161), and the concentrated appearance of a special type of red slipped jars with bands of horizontal black painted stripes (e.g. POTTERY, VI.8–19, et passim), clearly belonging to the Gupta period.

Levels 14 to 12, still aligned in the same direction as Level 15, show no distinct datable features except a conspicuous concentration of moulded “lotus”-bowls with and without stand (e.g. POTTERY, VI.78–79), and of crude grey stone plaques depicting Hindu gods and goddesses for domestic worship, a type of image which is living on up to medieval times. Contrary to such *groups* of finds one has to be cautious with regard to *single* objects found in these disturbed levels, as for instance, the two late medieval and muslimic coins (COINS, nos. 118; 124) which certainly do not belong to them. There is, in fact, no coin helping to date these levels; but judging from the structural sequence and according to the context of the safe group finds, Levels 14 to 12 belong in all probability to Post Gupta and Early Medieval times.

Level 11 presented not only a singular construction in form of a caravanserai but introduced also a new era of building conceptions resulting in a change of the alignment of walls. They follow no longer the old course, but they are arranged nearly diagonally to the cardinal directions, as did from now on all the structures following Level 11. As discussed in the structural report, the caravanserai may have existed for a comparatively long period and may not have been used for a longer time after its desertion, although Levels 10 and 9 partly reached down to the floors of Level 11. An exact dating of this level and the following one is not possible, but besides the finds of typical pottery and the continuation of the appearance of the grey stone plaques mentioned above, there have to be considered a number of coins mostly recovered as stray finds but nevertheless testifying the presence of structures belonging to the time when those coins were valid. One of them has been found below a floor of Level 9 but was presumably passed on from Level 11 or even 12. It is a silver coin of the Indo-Sassanian type of the time of Viṅrahapāla and his Successors, to be dated into the

10th century AD (COINS, no. 108). Other specimens, all stray finds, represent the Muslim Dynasties of Delhi, i.e. the Turks (Iltutmish, no. 109), the Khaljis (Jalaluddin Firuz II., no. 110), the Tughluqs (Firuz Shah III and Mahmud II, nos. 111–112), and the Lodis (Ibrahim Shah II, no. 113). They are followed by coins of the Suris (Sher Shah and Islam Shah, 114–119), four of which were concentrated in Level 8.

Considering the sudden change in the building conception and the strange construction of a caravanserai it seems possible that Level 11, after a period of abandonment of Level 12, was erected in the time of the Turks of Delhi. Should, on the other hand, the Gadhaiya coin of the 10th century give the date for Level 11 then the following Levels 10 to 8 would represent the time of the Muslim Dynasties. In any case, four of the five coins of Sher Shah Suri (nos. 114–118) have, as just mentioned, been found in the range of Level 8 providing a trustworthy date and indicating the near end of the Pre-Mughal period.

Thus the question arises whether the first of the three successive fortress Levels 7 to 5, built solely of baked bricks, has still to be assigned to Sher Shah or whether it belonged to the time of the Mughals already? Unfortunately, these fortress levels did not yield any clearly datable find. Among the pottery the delicate ware of moulded jars and bottles with rich relief decoration, coming up in Level 8, continues. The coins recovered were all stray finds and again not sufficiently helpful for an exact dating. There are seven coins of Akbar, three of Jahangir, one of Shahjahan and one of Aurangzeb (COINS, nos. 120–131), one Akbar and two Jahangir specimens of which have a chance to hail from Levels 7/6, while the Aurangzeb coin might come from Level 5. But at the end of Level 5 the fortress was, in all probability, in the hands of the Jāṭs coming to power in this region as a result of the Mughal misrule at the close of the 17th century.

The last constructional phase of the citadel began with Level 4, quite conspicuous by its strong ramparts of mud covering now the old fortress walls. This method of excessively piling up mud for defense was adopted also for building the gigantic mud fortifications around the locality of Dig, situated near to Sonkh, under Badansingh of Bharatpur (1722–56). The fortress of Sonkh of the Level 4 has in all probability been reconstructed latest in 1730 when the prince regent Sūraj Mall erected the rubble-and-mud citadel of Dig which was surrounded by a similar wide moat as did the Sonkh citadel in the time of Level 4.

The hey-day of the Jāṭs in this region did not last long. After the reign of Sūraj Mall (1756–63) and his son Jawāhir Singh (1764–68) the decline of the Jāṭ power began. In 1770 Sonkh found itself in the centre of a decisive battle between the Jāṭs and the Marāṭhās which was, as a historian reports, fought near the fort of Sonkh (Qanungo, 1925, pp. 231 f.) One will not be far from the truth with the presumption that the active time of the fortified citadel of Sonkh, temporarily a stronghold of the Jāṭs, came to an end with this event. For some decades more the residence quarters in the citadel were occupied and here and there reconstructed and rebuilt, but finally the place had to be abandoned for unknown reasons.

IV. THE FINDS

A. TERRACOTTA OBJECTS

1. Human Figurines

During the excavation a great number of terracotta objects were recovered, among them not less than seven hundred and sixty-eight mostly fragmentary human figurines. There are, of course, many too tiny or irrelevant fragments not worth to be published. But on the whole two hundred and sixty-three specimens have been selected for description and illustration. Eighty-eight more fragments will appear as duplicates or comparable specimens under the number of their prototype. All the pieces will be presented in their stratigraphic context, but arranged according to type within the respective period. The technical, iconographical and historical details, as changes in shape and style and eventual token of development, will be discussed in full length in the introductory remarks to each period separately.

Most of the types of figurines or fragments of them can be assigned to distinct periods or have been found just overlapping the next one. But there are two groups of terracotta figures which are surviving for a longer period or can not be associated with any style because of their simple nature. The first group is that of the Nude Dwarfish Male Figures, the second comprises the so-called Tribal Figures which are shaped beyond any line of style. They will be dealt with in the Terracotta Appendices 1 and 2 together with their stratigraphic data.

Period I

Period I, comprising the Painted Grey Ware Levels 40 to 37, is devoid of any human terracotta figurines. The only figurative terracottas found in these levels are the two fragments of bulls registered under ANIMAL FIGURINES.

Period II. Figurines from Levels 37 to 29

These levels cover the span from the earliest Maurya time up to the late Śuṅga Cultural Phase. Altogether 75 usable fragments of human terracotta figurines can be assigned to this period. Of them, 38 objects have been found in secure spots of the stratified levels and can, therefore, be accepted as evidence for chronological purposes. Five more pieces lying in the immediate vicinity of ditches have not been counted as stratified finds although they presumably can be taken as "clean". The remaining objects came from spots in later levels or were registered as stray finds, all of them, consequently, out of context. As the stratified fragments, however, convey specific stylistic features it is in most of the cases of unstratified pieces possible to assign them convincingly to stratified types.

With the exception of one demonic face and a few early fragments of indistinct male figures the bulk of heads and busts depict females. There is no reason to enter the discussion whether the free-standing female figurines of the Maurya to Śuṅga periods from Mathura represent the Mother Goddess (who is Aditi) or whomsoever. As there are no specimens carrying a child in the arm, they are just females without any other distinctive marks. The more so, as mostly the head or the body is preserved. The often rich ornamentation of the head and body rather suggests a character of beauty, as e.g. with *Surasundarī*. It is, therefore, expedient to name these fragments of figures simply as females.

The four early fragments of male figures (nos. 1, 3, 4 and perhaps

5) together with the assigned pieces (nos. 4a–d) are interesting specimens because terracotta male figurines are rather rare in the early phase of this period. In spite of the differing facial features, they share, as far as preserved, two stylistic marks: 1) a bulge of (cloth or wreath-covered) hair on the left side of the head, anticipating perhaps the turban, and 2) a tight fitted collar around the neck (esp. so in nos. 4a, c–d; cp. also the demonic male head of no. 2).

Much more helpful sources for the determination of a stylistic development in the terracotta art of this period are the fragments of female figures. There is no reason to doubt the emergence of two main types of female figurines succeeding each other within the levels 36 to 30 at Sonkh. The transition from the one to the other type, to be distinguished mainly by the shape and facial features of the figures' heads, came about step by step. While the first type is to be found overlapping with the new one, the second type develops within the levels 33 to 31. In chronological terms, the types belong 1) to the Maurya period, and 2) to the Śuṅga Cultural Phase (Śuṅga C. P.) of Sonkh, although the stylistic change need not to coincide with the change of the historic dynasties.

Before describing the essential features of the two main types of the female heads in this period II of Sonkh a few remarks on the singular figure no. 6 are necessary. The "beak" type of female figures is generally accepted as the earliest type of terracottas from Mathura, often dated as pre-Maurya. The fragment no. 6 has been found in a later level at Sonkh and can, consequently, not be used as chronological evidence. However, there is little doubt that from the point of technique and material this type has to be placed at the beginnings of Maurya terracotta art.

The fragments of the terracotta figures of this period are, as a rule, of grey colour and show very often a black slip. In this early phase, another colour (red or brown) is to be found only with the heads which have been made for decorative purposes, e.g. for attaching it on the shoulder of a vessel (no. 15). With the appearance of terracotta plaques and, more obvious, at the end of the Śuṅga Cultural Phase the brown-red varieties are increasing.

The *Maurya type of female heads* is documented in nos. 7, 10, 13, 14, 15 and 16. Although different in details, partly caused by the varying functions of the head, a considerable number of identical marks can be established here. In all the specimens the face and hair with pearl-chain is moulded on a hand-made clay-base. In case of an elaborate head-dress, the single parts (like rosettes, streamers etc.) are, as a rule, moulded separately and applied after the impression of the face. The head with its decoration ends in a tenon going to be inserted into the hand-modelled body. The neck-joint between head and body is in most of the pieces luted with clay or covered with a tight-fitted collar. This method is, of course, not applicable to heads which are produced for decorative purposes only.

It is the moulded face with hair-dress alone that gives the type its characteristic marks, which are: 1) a long-drawn face with high cheek-bones and narrow chin, 2) almond-shaped eyelids, 3) unmarked arched brow-ridges, 4) comparatively small mouth with no vertical folds at its corners, and 5) middle-parted hair decorated with a two-stringed pearl-chain. This combination of marks was binding for a long time, not only for the heads of the female figurines but also for those used for decorative purposes. The additional head-decorations could change. The ear-rings could be made single or double, and in case the general fashion of a big rosette on top and a circle of rosettes around the head (nos. 10, 10a) or one streamer each beside the face (nos. 12–14) was followed, the way for more and even excessive adornment was open. A remarkable change is heralded in the nos. 16 and 17, where two

of the six regularly used characteristic marks underwent an interesting modification: Instead of the middle-parted hair the oblique pearl-string is arranged in an angular way as if to serve as a substitute for the parted coiffure. What looks like a simple alteration of details turns out to be a transitional step compared with no. 18 and the following group. From now on the pearl-string is always angularly arranged.

The just mentioned no. 18 is an extremely noteworthy find because it is 1) the only and earliest plaque among all terracotta fragments of this period, and it contains 2) the earliest depiction of a completely new facial type of female, as represented in all round-modelled terracotta heads from now on.

The face of the elder female in no. 18 shows a shape quite different from that of the preceding type. Its contours are best described when compared with an egg the broad side of which marks the chin. The stratified heads nos. 19, 20, 22, 26, and 28, all displaying such egg-shaped face, turn out to represent as distinctive a type of its own as the preceding Maurya version.

Technically these heads are produced differently. Not only the faces but also the complete decorations around the head are now, as a rule, moulded. There are only few exceptions (see e.g. the description of no. 24). The practice of joining the moulded head to the hand-made body is the same as with the preceding type.

Although head and decoration are moulded in full, the characteristic marks of this type, i.e. the *type of the Śuṅga Cultural Phase*, are again hidden in the face and hair-part, which are 1) an egg-shaped face with broad cheeks, 2) an additional browline between upper eyelid and brow-ridge, 3) clear vertical folds beside the corners of the thick-lipped mouth (laughing folds?), 4) hair not middle-parted but showing a rectangular cut on the forehead, 5) the oblique double pearl-string arranged angularly, being tangential to the upper part of the head.

As in the Maurya type, the additional head-decorations are topped with a relatively big rosette (missing in nos. 19–22) and are, as a rule, encircling the head with decorative discs (nos. 19–21) or framing it with streamers descending to the ears (nos. 22–23). The variant with adorned streamers (no. 23) indicates by its protuberant lateral bulges and the clear central position of the rosette on top of the head an unmistakable step towards a tripartite head-dress so fancifully developed in the female terracotta plaques of the following period. It also becomes obvious in no. 24 which in addition shows first alterations of the characteristic marks: the rectangular hair-cut is absent, the pearl-strings are arranged more angular and punctured brows, placed directly on the brow-ridge, are introduced. With this type the free-standing, generally grey-coloured human, esp. female figures of the early terracotta period disappear, the technique of red/brown terracotta plaques predominates from now on.

1. Hand-made head of a male figure of bluish grey colour with applied strands of hair and moustache and incised beard. This is a stylistically unique specimen of early Indian terracotta art from a stratigraphically flawless find-spot (Level 34). The long-drawn head is crowned by a lateral bulge on its left, likely a cloth-covered chignon. A strand of hair, splitted in two on the top of the head is applied in slanting lines along the edge of the bulge. The wings of the dominant nose are stretching from cheek to cheek. The eyes and brows are carefully incised, leaving the eyeballs flat, thus creating an impression of blindness. The ears or ear-studs show wedge-like cuts. Mouth and chin are broken away, but the remains of an applied, upwards twirled moustache as well as of a beard incised in wavy lines are visible at the sides. The neck, or tenon in place of neck for fixing the head is attached in an asto-

nishingly oblique position. Thus the chin was either turned up in some sort of arrogant posture or the head was a decorative part of a vessel or any other object.

H. 8.0cm. Colour: Bluish grey. No. So I 378.

Find-spot: 2 IV 6.0/Cc 2.3, H. 15.80m.

Early Maurya. L.34

2. Head and fragmentary bust of a demon. Moulded face on hand-made figure. Deep-sunk circular eyes and flattened nose in monkey-like face above the broad grinning mouth. Around the back of the head the worn remains of some sort of hood are visible. A tight-fitting rounded collar decorated with punched dots is applied to the neck.

The symmetric projection below the collar raises doubt if the head is really a part of a human body.

H. 7.5cm. Colour: red-slipped. No. So I 206.

FS. 3 I 10.0/Ca 14.7, H. 16.55m. Maurya. L.33

3. Moulded female (or male?) face on hand-made patch of clay. Finely shaped face with prominent nose and mouth but deep-set eye-socket. Lenticular eyelids frame the pricked eyeballs below hard-edged browbone. On the head two bulges arise representing presumably the bipartite hair in cloth-covered chignons. The bigger one above the left ear is tied by a ribbon indicated by a grooved curved line. There are no traces of ears. The back is unmodelled. As the neck projects backwards it is safe to assume that the head was attached to the shoulder of a vessel.

H. 3.9cm. Colour: grey. No. So I 209.

FS.3 I 8.5/Ca 18.3, H. 16.42m. Maurya. L.33

4. Bust of hand-made male figure with angular face of the “beak”-type, i.e. the nose ridge is formed by pinching the cheeks. The mouth is absent, the eyes are indicated by grooved circles with central point for the pupil. The cloth-covered hair (?) is spread like a saddle on the head with a protuberance on the left side, consisting of a mass of hair bound by a punch-marked ribbon or its own plait. From the hair-ball and the opposite edge of the “saddle” a loop is hanging down as if covering the ears. To the clumsy neck a tight-fitting collar is applied decorated with one line of stamped circlets. The arms are projecting horizontally from the shoulders but bent in the elbows; the forearms are missing.

H. 6.9cm. Brownish with olive slip. No. So I 93.

FS. 2 I 18.0/Bd 18.5, H. 19.90m. Trench 4.

Late Maurya

a) Torso of a male figure with tight-fitting collar and horizontally extended arms. Grey. Similar to above.

Ht. 3.0cm. So III A 3007. FS. 2 IV 7.0/Be 15.5, H. 18.00m.

b) Mutilated fragment of similar type.

Ht. 5.3cm. Colour: Brown. No. So III A 3582.

FS. 2 IV 15.5/Cc 3.0, H. 16.00–15.85m.

c) Torso of male figure similar to above.

Ht. 10.9cm. Colour: red. No. So III A 976.

FS.2 V 13.05/Cb 19.67, H. 22.87m. Out of context.

d) Fragment of a male figure of similar type. Head turned sideways, looking over right shoulder.

Ht. 8.6cm. Grey, black-slipped. No. So I 141.

FS. 2 IV 1.25/Cb 4.55, H. 23.8m. Out of context.

5. Bust of a male or female figure. Face moulded on hand-made head-part of body. Slim long-drawn face with narrow chin and broad eyes framed by lenticular eyelids. The forehead is adorned with a single pearl. In the middle, the head is covered with pearl strings. At the sides, cloth-covered bulges take up the mass of

hair. To the left, a turban-like ribbon is wound around both the protuberances from which a loop is hanging down, missing now on the right. The face is moulded as if inclined to the side. In the front, the neck was adorned with a collar preserved only fragmentally. The arms, now mostly missing, were extended horizontally. The back is unmodelled.

Ht. 6.9 cm. Colour: grey, traces of black slip.
No. So I 95. FS. 2 I 17.45/Bd 16.1, H. 19.95 m.
Trench 4. Late Maurya

6. Unstratified fragment of a hand-modelled female figure with damaged animal-like face, rhombic eyes, circular mark on the forehead and three patches of hair falling down on the front. Above the round breasts remains of a collar consisting of applied dented pieces of clay are visible from which a band hangs down, covered at its end by a broader, decorated string running from the shoulder towards the middle of the body. On the back, the hair is indicated by three parallel appliqué strands adorned with punched circlets.

H. 7.8 cm. Colour: light grey. No. So I 133.
FS. 2 V 9.85/Ca 10.65, H. 23.45 m.

As the fragment was found in a later stratum it cannot be dated stratigraphically. From the point of technique it has to belong to the early Mauryan period.

7. Head of a female figure with moulded face and typical features, as small mouth, lenticular eyelids without marked eyebrows, middle-parted hair covered by two strings of pearls. The ears are chipped off. On the hand-made piece of neck and body a collar is indicated by four grooved horizontal lines with three pendants. No remains of an adorning hood. The back of the head is kneaded round.

H. 5.2 cm. Colour: grey, black slip. No. So I 277.
FS. 3 I 6.5/Ca 16.8, H. 16.50 m. Maurya. L.33

8. Female head of the same type and technique as no. 7. The neck ends in a tenon to be inserted into the hand-made body. Ears missing as with no. 7.

H. 5.2 cm. Grey, traces of black slip. No. So III A 3665.
FS. 2 III 10.65/Cc 2.9, H. 18.45 m. Out of context.

9. Female head. With the exception of the preserved huge double ear-rings of much the same type and technique as no. 7. On the head, just behind the oblique two strings of pearls traces of four ornaments (rosettes?) are visible. Under the decorated neck the tenon for the insertion of the head into the body is preserved. The back of the head is modelled in the round.

H. 5.0 cm. Grey with black slip. No. So I 188.
FS. 2 IV 8.5/Cb 3.0, H. 22.40 m.

Find-spot out of context. On the analogy of no. 7 to be classified as Mauryan.

a) Head of a female figure of the above type with two rosettes separately applied vertically behind pearl strings above middle-parted hair.

H. 5.2 cm. Colour: grey with traces of black slip.
No. So I 210. FS. 2 V 19.8/Ca 16.3, H. 22.00 m.
Out of context.

b) Mutilated fragment of head and bust of a female figure of the above type.

H. 6.5 cm. Colour: brown. No. So III A 2731.
FS. 2 IV 2.8/Ca 19.7, H. 22.56 m. Out of context.

c) Face of a female figure of the above type.

H. 4.0 cm. Colour: grey. No. So I 64. Surface find.

d) Head of female figure of the above type. Neck runs out in a tenon.

H. 6.1 cm. Colour: grey. No. So III A 3666.
FS.2 III 13.2/Cc 5.8, H. 18.70 m. Out of context.

10. Fragment of head and bust of a female figure. Typical face (as described above) moulded on head-base of hand-made body. Huge double ear-rings. Hood squeezed to front. Former ornamental application now chipped off, leaving five fracture marks. Head-part stuck with tenon into body. Broad, clay-smear neck. Horizontally arranged collar of vertically grooved patches indicating beads. Stumps of arms slightly curved downwards.

H. 7.2 cm. Grey, black-slipped. No. So I 364.
FS.2 IV 14.1/Cc 6.95, H. 15.68 m. Maurya. L.33

a) Head of female figure of the above type. Ornamentation preserved as a wreath of six plus one central rosettes.

H. 6.1 cm. Colour: grey. No. So I 121.
FS.2 V 12.4/Ca 17.1, H. 23.25 m. Out of context.

11. Unstratified worn head of a female figure with described Mauryan features, showing pricked lines in the clay base above and to the sides of the head, serving as hold for ornamental applications.

H. 3.9 cm. Grey, black slipped. No. So I 244.
FS. Ditch in 2 V 12.9/Cc 7.3, H 20.64 m.

On the analogy of no. 10 and previous Mauryan heads this has to be dated to the Mauryan period.

12. Mutilated head and bust of a female figure with the long-drawn face, lenticular eyelids below unmarked browbow, middle-parted hair and horizontally arranged double pearl strings of the Mauryan type. In this type long streamers are impressed to the sides of the head, inclined towards a central rosette on top. The streamers in this piece are both ornamented with punched circlets. To the side of the right streamer (seen from front) remains of an additional decoration (here a single rosette) is visible, as is the case with all specimens of this streamer type. The streamers can be added by direct punching on the clay-ground, as done here, or by application of separately moulded bands and rosettes (see nos. 13,14). The neck is in front adorned by a collar, the decoration of which is worn.

H. 9.0 cm. Grey, black slipped. No. So I 355.
FS. 2 IV 16.1/Cc 0.9, H. 16.35 m. Mauryan. L. 32

a) Worn head of similar type as above. The additional decoration on the right consists of a lotus rosette and a pearl disc.

H. 6.6 cm. Grey, traces of black slip. No. So I 80.
FS. 2 IV 7.57/Ca 7.06, H. 25.80 m. Out of context.

b) Weathered head as above. With additional rosettes as a).
H. 7.2 cm. Grey, black slipped. No. So III A 3184.

Ditch-find in 2 IV 2.1/Cc 3.3. Out of context.

c) Mutilated head of above type. Collar of wheel-like discs.
H. 7.6 cm. Grey, traces of black slip. No. So I 104.

FS. 2 IV 6.6/Ca 2.35, H. 24.55 m. Out of context.

d) Head without hood decoration. Collar of vertically grooved patches (= beads). On back, remains of hair plaits.

H. 7.5 cm. Grey, traces of black slip. No. So I 271.
FS. 2 V 5.3/Ca 11.8, H. 19.50 m. Out of context.

13. Head of a female figure with moulded face of Mauryan features on hand-made hood carrying profuse ornamentation. Originally one long streamer each was applied to the sides of the face, crossing the large single ear-discs. The one on the right side is now chipped off. But part of the lotus rosette on top and the entire other streamer is preserved. They are separately moulded and applied. The band shows double-circlets with central pricks in two rows. The additional decoration on the preserved side con-

sists of two flower rosettes combined with foliage, arranged as if bound in a bunch and separately fastened beside and behind the streamer. The heavy embellishment is completed by an extremely broad collar showing the same ornaments as the streamer. On the back the smeared spot of fastening the bunch is visible beside tripartite hair-braids indicated by parallel strands parted by incised lines and decorated with punched circlets.

H. 6.9 cm. Grey with black slip. No. So III A 1882.
FS. 2 IV 11.7/Cc 4.0, H. 15.75 m. Maurya. L.33/32

14. Head of a female figure with moulded face as before. Double ear-rings. Streamer on the side of the right ear. Opposite decoration and top rosette lost. The separately moulded and applied streamer is showing the same circlets as no. 13 but without central prick. From above, two ribbons ending in hooks descend. The collar consists of bead-like patches decorated with punched circles. On the back a bipartite plait with incised geometric pattern and a fluttering ribbon is applied.

H. 6.8 cm. Colour: grey. No. So III A 407.
FS. 2 IV 10.92/Cc 2.55, H. 15.90 m. Maurya. L.32

15. Head of a female figure with the long-drawn moulded Mauryan face, i.e. lenticular eyelids below browless ridge and middle-parted hair under two pearl strings. On top and at the back clay is kneaded on and around the head indicating that no applications have been used. The neck is formed by a hollow projection with wheel-marks inside. The head therefore formed part of a vessel.

H. 5.8 cm. Light brown, dark-brown slip. No. So I 122.
FS. Filling of trench 4.

Although out of context, on analogy to nos. 7 and 13–14 the facial features permit the dating to the Maurya period.

16. Female head with long-drawn moulded face, lenticular shaped eyelids, punched eyeballs and dotted brows. Instead of middle-parted hair angular arrangement of the oblique two pearl strings. Fragment of applied streamer with moulded circlets above right ear. Ears partly chipped off.

H. 5.3 cm. Grey, black-slipped. No. So I 185.
FS. 2 IV 7.8/Cc 3.6, H. 16.50 m. Late Maurya. L.31

17. Unstratified head of a female figure similar to no. 16. Again angular arrangement of the two pearl strings instead of middle-parted hair. Ears and presumably decorated hood broken away. Notable collar consisting of three broad patches with stamped dots fitted in front of neck.

H. 5.2 cm. Grey, black slip. No. So I 162.
FS. 2 V 19.0/Ca 17.9, H. 22.70 m.

Out of context. On the analogy of no. 16: late Maurya

18. Earliest moulded terracotta plaque from Sonkh. Upper half of a female accompanied by a girl. Egg-shaped face of the woman, stamped rhombic eyelids with convex dot of pupil. Angularly arranged pearl string on hair (in the angularity comparable to nos. 16–17). Similar pearl strings fluttering as streamers around the head. On top voluminous flowery boss with dented marks. On right ear a roundish bulge indicating, for the first time, a trefoil form of woman's head-dress. The ear-discs are placed in different positions, i.e. frontal and sideways. The collar consists of a single string of pearls (*Ekāvalī*). The round breasts have grooved nipples. The girl on the woman's left stands breast to breast as if holding right arm around her back and being herself embraced by the woman. The face is worn but shows same rhombic eyes as the older female. Small ear-discs and an incompletely moulded pearl-collar adorn the figure. Above the mass of hair the coiffure ends in a funny bow. The back of the plaque is plain.

One may see in this pair mother and daughter, but it is certainly not mother and child in the sense of a mother goddess. From the stylistic point of view the egg-shape of the head with the broader side below is an important change, heralding the facial type of the Śuṅga Cultural Phase.

H. 7.2 cm. Colour: light brown with brown slip.
No. So I 213. FS. 3 I 12.0/Ca 14.3, H. 16.35 m.
Late Maurya/Early Śuṅga C. P., L.33/32

19. Head of a female figure. Face and head-dress completely moulded. Broad egg-shaped face with new characteristic features: full cheeks, vertical folds to the sides of the mouth, eyebrows placed between upper lid and brow-ridge, rectangular cut in the hair on the forehead and angular arrangement of the double pearl string. The latter being tangent to the upper part of head and ending below in a pendant-like circlet with central convex dot in height of the eyes. The head-dress is formed by four rosettes placed in a semicircle around the hair. In this type three of the rosettes are similar, showing punched dots only while the second to the left is shaped as a full-blown flower. The neck ends in a tenon for fixing the head on a hand-modelled body.

H. 7.4 cm. Colour: grey with black slip.
No. So I 211. FS. 3 I 9.8/Ca 14.9, H. 16.35 m.
Early Śuṅga C. P., L.33/32

20. Head of a female made from a perfectly similar mould as no. 19. Exactly the same features.

H. 5.8 cm. Colour: grey, black-slipped.
No. So I 266. FS. 3 I 6.5/Ca 8.2, H. 16.80 m.
Śuṅga C. P., L.32/31

21. Head of a female figure similar to nos. 19–20. Head ornaments partly broken away.

H. 5.1 cm. Grey, black-slipped. No. So I 149.
FS. 2 IV 11.35/Ca 0.65, H. 23.20 m. Out of context.

a) Mutilated head of same type of female figure.

H. 7.6 cm. Colour: grey-brown.
No. So I 68. FS. Filling

22. Head with mutilated head-dress of a female figure. Moulded. Face of the type described in no. 19. Ornamentation of head-dress different from nos. 19–21. The head was encircled by streamers decorated with punched circlets filled with convex dots.

H. 5.5 cm. Brownish, with traces of burning.
No. So I 267. FS. 3 I 5.7/Ca 12.2, H. 17.00 m.
Śuṅga Cultural Phase.

23. Unstratified specimen of female head similar to no. 22. To the sides of the characteristic Śuṅgan head full streamers with circlets like those in the preceding piece are preserved. The needle-strokes at the lateral bulges give the streamers the look of peacock feathers but in comparison with nos. 24–25 one has to identify the bulges as masses of hair. Above the head remains of a decorated central boss are visible. A knobbed disc is fastened to the right ear.

The streamers with the striped bulges together with the boss on top form a clear trefoiled head-dress as anticipated already in no. 18.

H. 7.6 cm. Colour: grey.
No. So I 47. FS. Filling. N. E. tower.

24. Unstratified head of a female figure of Śuṅgan type showing remarkable changes in stylistic details and technique. As to the face, the eyebrows are marked by conspicuous dotted lines fitted directly to the brow ridge. Secondly, the rectangular hair-cut on

the forehead is, in this type, missing. The trefoil form of no. 23 is emphasized here by a complicated technique: the face with pearl strings and pendants as well as the top rosette (damaged) is moulded directly on the ground patch of clay, the bulges on the sides are formed separately and applied afterwards. There are clear joints visible between ground and appliqué parts. The streamers are ornamented with rosettes in the shape of wheel and flower and a square piece of jewelry in the centre.

H. 4.5 cm. Colour: grey, black slip. No. So I 175.

FS. 2 IV 19.5/Ca 11.3, H. 22.60 m. Out of context.

25. Moulded head of a female figure from disturbed layer in 2 III/Cc. Egg-shaped face with dotted eyebrows as in no. 24. Perhaps pearl on forehead. Trefoil form of head-dress. Cloth-covered hair-bulges in shape of horns on the sides, on top a voluminous flower boss. Huge but mutilated ear-rings. Back unmodelled.

H. 4.2 cm. Colour: red, brown slip. No. So I 384.

FS. 2 III 14.8/Cc 6.3, H. 18.40 m. Out of context.

Presumably advanced stage of Śuṅga C. P.

26. Female head from shoulder of a vessel. Face as in nos. 19–21. Rectangular hair-cut on forehead, two strings of pearls tangent to upper part of head. Cloth-covered bulge of hair above left ear. Traces of wheel-marks inside the neck extension.

H. 3.7 cm. Grey, black-slipped. No. So I 268.

FS. 3 I 8.4/Ca 14.3, H. 16.75 m. Śuṅga C. P. L.32/31

27. Moulded female head with facial features as nos. 19–21. No framing decoration. Clay simply smoothed around head. Hair indicated by thin incised lines. The neck-projection proves this head to be a decorative part, presumably from the shoulder of a vessel.

H. 3.7 cm. Brown-grey, dark slip. No. So I 343.

FS. 2 IV 13.8/Cc 3.0, H. 17.20 m. Found in ditch.

28. Moulded female head as no. 27. Presumably from vessel-shoulder.

H. 4.2 cm. Colour: light grey with black slip.

No. So I 249. FS. 3 I 5.55/Ca 12.80, H. 17.90 m.

Advanced Śuṅga C. P., L.29

29. Female head as no. 27 from shoulder of a vessel. Same but clearer facial features as preceding type.

H. 4.25 cm. Colour: red-brown.

No. So I 75. FS. 2 IV 3.15/Ca 8.77, H. 26.05 m.

Out of context but on the analogy of no. 28 to be dated to Advanced Śuṅga C. P.

a) Mutilated head of a female figure from vessel-shoulder.

H. 3.4 cm. Colour: light grey with dark slip.

No. So III A 3566. FS. 2 IV 9.35/Cc 6.15, H. 17.15 m.

Advanced Śuṅga C. P., L.30

30. Indistinct architectural (?) terracotta object with face-type of the Śuṅga C. P. The lower part of the object extends as a broad tenon. On top of the head a 0.5 cm deep hole in shape of a semicircle is visible. The back is damaged.

H. 14.5 cm. Face red-brown, tenon blackened by fire.

No. So I 334. FS. 2 IV 0.2/Cc 7.5, H. 19.75 m.

Out of context.

31. Head of a male figure wearing a turban with a protuberance on the left side, covering a mass of hair. Eyebrows incised, pupils indicated by a prick. Ears and back of the head kneaded.

H. 3.9 cm. Brown with red-brown slip. No. So I 92.

FS. 2 I 17.1/Bd 18.4, H. 20.20 m (ashpit of trench 4).

Advanced Śuṅga C. P.

Headless Human Terracotta Bodies of Period II

While the heads of stratified figures from the Maurya period and the Śuṅga Cultural Phase have proved to be discernible by characteristic features, the torsos and fragments of the hand-made bodies, in total absence of complete figurines, do not give any clues to classify them as belonging to the one or the other of the two periods. The noticeable pieces from Sonkh are, like the heads, arranged here according to their stratigraphic position in all the cases of a safe find-spot or clear analogy. Other stratified but negligible, and not stratified but assignable fragments are listed under the comparable object as a), b), etc.

32. Fragment of a female figure from waist to feet. Small piece of applied girdle on right hip, the broken part leaving a broad greyish marking. Navel indicated as a big circular pit. Waist tapers rather straight from hip to armpits. Legs separated by an arch, the feet below show single anklets without details of toes. Back flat. *The earliest fragment of a hand-made terracotta body from Sonkh.*

H. 11.7 cm. Grey, black slip. No. So III A 3544.

FS. 2 IV 2.15/Cc 4.4, H. 13.90 m. PGW-slope, southwest corner.

Pre-Maurya, below L.35

33. Fragment of a female figure from waist to feet. Harmonious roundish shape of body from hips to breast. Remains of applied punched streamers hanging down to the sides of big navel pit. Preserved half of girdle consists of an applied band provided with plain circular discs, the chipped off part has left a greyish mark. Legs separated by an arch, right foot below single anklet without details of toes. Back flat.

H. 12.0 cm. Colour: brownish grey with brown slip. Right leg and hip blackened by fire.

No. So I 197. FS. 3 II 7.5/Ca 14.0, H. 16.60 m.

Maurya. L.33/32

a) Fragment of hip-part of a female figure. Tips of streamers to right and left side of big navel pit. Applied girdle provided with vertically lined discs.

H. 4.7 cm. Colour: grey. No. So III A 1541.

FS. 2 IV 7.7–9.5/Ca 11.0–13.0, H. 22.12–22.46 m.

Out of context.

34. Fragment of female figure from waist to thighs. Similar but broader shape of body as no. 33. Tips of streamers to the right and left of circular navel pit above which a pendant descends. Profusely ornamented girdle consisting of four horizontally applied strings showing from top 1) broad patches with punched dots, 2) round flat discs, 3) cylindrical rolls, and 4) patches with vertically grooved lines. Back flat.

H. 7.4 cm. Grey-black, traces of black slip.

No. So I 94. FS. 2 I 17.5/Bd 18.95, H. 19.50 m.

Trench 4. Maurya.

35. Worn fragment of a female figure from waist to thighs. Angular hips. Big navel pit surrounded by seven punched circlets above chipped off girdle. Triangular breach from right thigh to right hip.

H. 7.5 cm. Colour: grey, traces of black slip.

No. So I 370. FS. 2 IV 14.2/Cc 4.0, H. 15.70 m.

Maurya. L.33/32

a) Fragment of waist-part of female figure. Big navel pit above which three-lined streamers descend. To right four punched rings.

H. 6.4 cm. Colour: grey, traces of black slip.

No. So III A 3624. FS. 2 IV 12.6/Cc 2.0, H. 15.10 m.

Maurya. L.34

b) Fragment of a female figure from abdomen to thighs. Nine punched circles above navel pit. Mutilated girdle rendered by a horizontal band with vertical incisions.
H. 5.8cm. Grey, black slip. No. So III A 2952.
FS. 2 III 16.0/Cc 1.0, H. 20.70m. Out of context.

36. Headless female figure with rich ornamentation: 1) horizontal line of punched circles on neck, 2) collar of broad patches with vertically grooved strokes, the middle patch applied directly upon breasts, 3) necklace of similar patches from shoulders to navel which is covered by a central bulgy and punctured pendant, 4) double line of punched circles on right, single line on left hip, 5) horizontal girdle decorated by vertical grooves and single line of punched circles above it. The figure exhibits high-drawn hips and comparatively slim thighs. The feet are broken away. Back flat.
H. 11.3cm. Colour: grey, traces of black slip.
No. So I 363. FS. 2 IV 15.8/Cc 8.5, H. 15.70m.
Maurya. L.33/32

a) Mutilated fragment of a female figure from waist to thighs. Big sunken navel. Horizontal girdle decorated by vertical grooves. Back flat.
H. 8.4cm. Colour: grey, traces of black slip.
No. So III A 3404. FS. Ditch in 2 III/Cc.

b) Fragment of a female figure from waist to thighs. Navel pit with punched circle in centre. Horizontal girdle with few vertical cuts. Above and below girdle a horizontal row of punched circles. Back flat.
H. 8.1cm. Grey. No. So I 2. FS. Surface find.

c) Fragment of headless female figure. Collar consisting of bread-shaped patches resting upon breasts. Big navel. Vertically grooved girdle.
H. 10.6cm. Colour: grey, black-slipped.
No. So III A 681. FS. 2 V 5.7/Cb 7.8, H. 22.65m.
Out of context.

d) Similar fragment as no. 36c. Remains of collar on left shoulder and breasts. Mutilated girdle, big navel.
H. 9.5cm. Colour: red, traces of grey slip.
No. So I 101. FS. 2 IV 12.55/Ca 7.65, H. 24.75m.
Out of context.

37. Fragment of a female figure. Head, arms, breasts and portion below girdle missing. Slender waist, broad hips, big navel pit. Plain, tightfitted collar crossed by a narrow, circle-punched streamer descending from right ear. Corresponding band on left side chipped off. Above and below navel a horizontal double row of carelessly punched circles. Back unmodelled.
H. 9.2cm. Grey, traces of black slip. No. So I 362.
FS. 2 IV 16.4/Cc 8.4, H. 15.72m. Maurya. L.33/32

38. Headless female figure with slightly bent and partially broken off arms. Big sunken navel, applied girdle with vertical grooves. Slim thighs, separated by rather round arch. High hip-line, short waist. Back unmodelled. Carelessly made figure.
H. 11.9cm. Grey, black-slipped. No. So I 360.
FS. 2 IV 16.8/Cc 7.8, H. 15.75m. Maurya. L.33/32

a) Fragment of a female figure from right shoulder to hips. Big navel, applied girdle with oblong bead-like impressions.
H. 8.8cm. Colour: grey. No. So III A 756.
FS. 2 IV 4.4/Ca 2.55, H. 24.00m. Out of context.

39. Torso of a female figure. Angular hips and slender waist. Collar tied in a bow above breasts. Grooved navel, mutilated girdle below hipline. Back unmodelled.
H. 9.0cm. Grey, black-slipped. No. So I 367.
FS. 2 IV 13.4/Cc 6.05, H. 15.80m. Maurya. L.32

40. Fragment of a female figure. Part of right hip with girdle, decorated completely with punched circlets.
H. 3.0cm. Grey, black slip. No. So III A 3531.
FS. 2 IV 10.5–11.2/Cc 4.2–8.5, H. 16.20–16.05m.
Maurya. L.32

41. Fragment of a female figure. Bust with right breast and stump of right arm. Tight fitting collar consisting of applied wheel-discs around neck. Back flat.
H. 4.9cm. Grey, black-slipped. No. So I 366.
FS. 2 IV 13.1/Cc 3.3, H. 16.15m. Maurya. L.32

a) Similar fragment as no.41 with remains of wheel-decorated collar.
H. 4.2cm. Grey, black-slipped. No. So I 26.
FS. Trench 1, H. 16.10–15.50m. Maurya.

42. Fragment of a female figure from waist to thighs. Navel impressed. Applied horizontal girdle consisting of six wheel-shaped discs.
H. 6.6cm. Grey, black-slipped. No. So I 359.
FS. 2 IV 16.0/Cc 3.8, H. 16.20m. Śuṅga C. P., L.31

a) Fragment as no. 42. Mutilated girdle consisting of knobbed discs.
H. 5.8cm. Grey, black-slipped. No. So III A 1691.
FS. 3 I 1.0/Ca 13.0, H. 21.20m. Out of context.

b) Fragment as no. 42. Girdle decorated with four long bread-shaped beads.
H. 6.3cm. Grey, traces of black slip. No. So III A 2653.
FS. 2 III 16.0/Cb 19.05, H. 21.90m. Out of context.

43. Fragment of a female figure from waist to left thigh. Concave navel. Slightly curved mutilated girdle of undecorated round discs.
H. 7.0cm. Grey, black-slipped. No. So I 356.
FS. 2 IV 14.2/Cc 2.7, H. 16.35m. Śuṅga C. P., L.31

44. Torso of a female figure. At the neck an undistinct ball-shaped protuberance, perhaps a pendant. Necklace in shape of a loose ribbon from which two streamers descend to the side of the misshapen breasts. Big navel pit. Girdle rendered by a band of entwined loops.
H. 7.4cm. Grey, black-slipped. No. So I 376.
FS. 2 IV 8.35/Cc 1.6, H. 16.55m. Śuṅga C. P., L.31

45. Torso of a female figure. Necklace consisting of a ribbon with three undecorated streamers descending to the sides and between the breasts. Girdle rendered by a nearly horizontal band with vertical grooves.
H. 6.7cm. Colour: grey. No. So I 381.
FS. 2 IV 2.9/Cc 2.85, H. 15.50m.
Śuṅga C. P. Ditch from L.31/30.

a) Headless bust of a female figure. Tightfitting collar with seven dangling pieces of ribbon. Breast mutilated. Back flat.
H. 4.9cm. Colour: grey. No. So III A 3383.
FS. 2 IV 10.0/Cc 0.9, H. 18.75m. Out of context.

b) Fragment of a female figure. Remains of undecorated streamers to the sides and between the breasts. Concave navel. Small fragment of punctured girdleband.
H. 7.0cm. Grey, traces of black slip. No. So III A 682.
FS. 2 IV 19.8/Ca 8.9, H. 23.00m. Out of context.

46. Fragment of a female figure from waist to thighs. Almost conical shape of rump from hips to waist. Big navel pit. Mutilated girdle with traces of disc-like ornaments.

1



1a

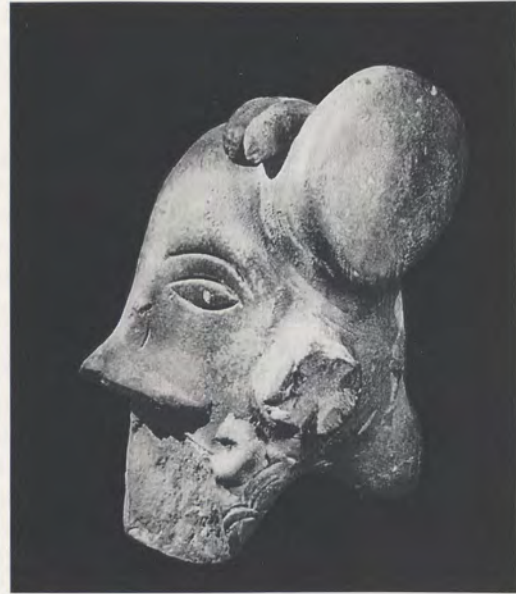

1b



2

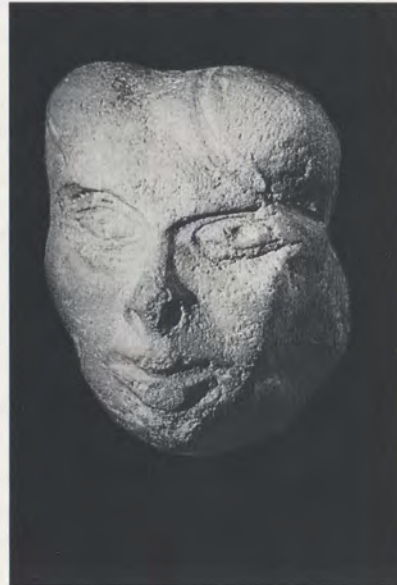

3



4



5



6a



6b

Terracotta Human Figurines. Period II



7



8



9



10



11



12



13



14

1



15



16



17



18



19



20



21



22



23



24



25



26



27



28



29

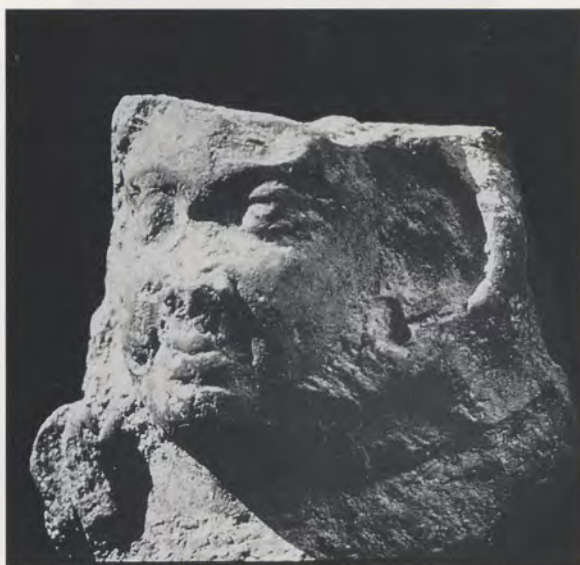

30



31

1



32



33

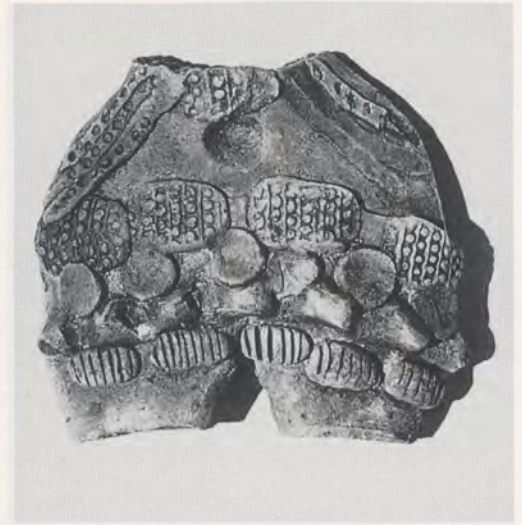

34



35



36



37



38



39



40



41



42



43



44



45



46



47

H. 6.3 cm. Grey, black-slipped. No. So III A 3009.
FS. 2 IV 3.6/Be 15.6, H. 18.95 m.
Advanced Śuṅga C. P., L.30

47. Unstratified fragment of a female figure from waist to girdle. Body stamped with three oblong ornaments around big navel pit. Girdle consisting of an applied band with the same stamp impression as on body.

H. 8.0 cm. Grey, black-slipped. No. So I 88.
FS. Stray find.

Period III. Figurines from Levels 29 to 24

Historically these levels cover the time from the close of the Śuṅga Cultural Phase to the end of the Mitra dynasty of Mathura and the appearance of the Kṣatrapas. The number of usable terracotta figurines and fragments of such assignable to this period sums up to 70. Of them, 55 objects hail from secure stratified spots in their respective levels. The other 15 have been found in higher levels or were registered as stray finds. On the analogy of stylistic features they could be allotted to the one or the other level of this period. *Technically* the free-standing, commonly grey-coloured human, esp. female figures of that time had to make room for terracotta figures of a greater variety in make, style and iconography. The rapid changes perceptible in this period made it necessary to subdivide the finds into three phases altogether.

The predominant product of the period is the red/brown terracotta plaque made from an open mould in which the back of the plaque gets flattened by hand. These plaques are, as a rule, upright in shape and quite often colour-slipped.

The specimens of free-standing figures of this period are of various techniques. There is 1) the small group of riders with their clumsy hand-made body and moulded face (nos. 58–60 and sub-nos.); 2) the group of the hand-made and solid three-legged female and male figures of which regrettably no heads are preserved (nos. 70–72 and sub-nos.); 3) the hand-made “winged” female (no. 78); and 4) the figures in the round made by two moulds, either hollow (nos. 64, 64a) or solid (nos. 65, 76, 77 and sub-nos.). Nearly all of the double-moulded figures show a white slip.

The *stylistic development* in this period is best represented in the depictions of the plaques from successive levels. Although one has to keep in mind that the finds in archaeological excavations present a selection only of all possible products of the time, it seems appropriate to point out a few characteristic marks of the varying types following each other.

The female figures principally show a tripartite head-dress consisting of lateral bulges and a flower in between or on top. The early pieces from levels 29 and 28 show these bulges richly decorated with garlands or ribbons. The rectangular gap in the hair on the forehead is still in use. The body, arms and legs are given in rather high relief radiating health. They wear a long dress reaching from the shoulders down to the ankles. The legs are shown frontal.

In level 27 the fashion of the coiffure of females seems to tend to a less decorative presentation of the lateral hair projections, topped by a lotus flower. In one case (no. 52) a feather-like finery is chosen as central ornament. The rectangular gap in the hair is not obligatory anymore. The dress is now, as a rule, short with side-panels of folded garment and reaching just below the knees, either put on smoothly or laid in folds which, gradually, become arranged differently, i.e. slanting on the right and running vertical on the left leg; the exception being again no. 52 where the

folds are lined up straight vertical on both the thighs. In the types of nos. 53–56 the feet of the women are placed sideways.

A number of fragments from levels 27/26 represent a special type of plaque in so far as they are conspicuously plane in make and show amazingly low relief and figures with remarkably thin extremities (nos. 63, 63a–c). This type seems to be restricted to plaques in which the male holds a flower-stalk towards the female. In these specimens the male wears a bunch of three upright lotusbuds in the head-dress which is a rare design (no. 62, see also no. 61 and, perhaps, no. 66).

With the exception of the matching head-dresses in some of the pieces the male figures originating from levels 27 to 24 (nos. 61–67, 73–74, 76) can not be related to each other. But it is a noteworthy observation that the type of dhoṭī with knotted girdle from which two fillets of different length hang down (a dress which is so well-known from the huge *Yakṣa* figures in stone) appears in the trend-setting terracotta art not earlier than level 25 (nos. 73, 76), i.e. in the later Mitra period (middle to second half of 1st cent. BC.).

The group of riders (nos. 58–60 and sub-nos.) is to be valued as products without any artistic merits. As there is no specimen with a rider still on horse, the horses will be dealt with separately under ANIMALS. As to the group of the three-legged figures the diversity of the few specimens is too great to draw conclusions on a correlation in style. Both the groups have to be registered as originating in this Period III but continuing over a long time.

It is difficult to catch the exact *iconographic meaning* of most of the figures of Period III without a special study on the single objects. One has to keep in mind that the first century BC is the very time when current religious ideas of India start to get transformed into pictures for the first time. There is no fixed iconographic canon available yet for the artist, he is answering the growing desire for images of the gods and goddesses according to his own imagination. In the terracotta art, an ever underestimated forerunner of the art in stone, the attempt is clearly perceptible to escape the customary work and to develop new religious figurations. Therefore, the figurines of this period are diverse not only in their manufacture but more so in their contents.

In the beginning, the single female figure is still dominant in all the finds. Nevertheless, they are not uniform any longer and one has to ask if they depict different goddesses. There are the females with fishes in one hand (nos. 51, 51a, 56 and, most probably, nos. 48–49), already heavily discussed by scholars, and there is the woman with an attendant in adoration (no. 50). The author does not wish to enter discussion on this occasion, but to him it seems obvious that in both the cases goddesses are depicted. A more inferior position seems to be adopted by the woman with raised left arm holding a flower in her hand (nos. 53–55 and sub-nos.) and setting the feet sideways (no. 55).

As to the couples, the pieces no. 61, 64 and 65 would, in the interpretation of V. S. Agrawala (1948: 109f.), have to be taken as *dampatī* or “husband-and-wife” type, because of the position of the man on the proper right side of the woman, and no. 73 as a *mithuna* plaque for showing a couple in reversed position. Judging from the finds at Sonkh, the couples in “married” position appear earlier than the (one) fondling duo.

These fragments of couples have to be regarded as being separate from the “man-and-woman” figures in nos. 62, 63 and 63a–b, where the position of the acting persons is changing at random. In nos. 62 and 63b the female is the left-hand figure of the pair, in nos. 63 and 63a this position is reverse, the male figure fills the left-hand side. It is this group of couples where the male is holding a flower-stalk towards the female. In connection with the rare

adornment of the man with the three lotus-buds in his head-dress and his bodily position towards the woman, the depiction conveys the impression of an act of worship rather than of a simple couple. Unfortunately, the miscarried reproduction of the only complete plaque of this type does not permit a better interpretation at the moment.

The plaques nos. 66, 67, 68 and 74 have to be studied thoroughly. Some remarks have been added in the descriptions but it looks as if these pieces could tell more about the religious life of their times. Of special importance is the plaque no. 75 which the author tends to interpret as the earliest depiction of the goddess Durgā Mahiṣāsūramardīnī.

At the end of this period the invasion of the Kṣatrapas seems to cast a shadow upon the scene. No iconographic development can be observed in the terracotta objects from levels 24 to 22, but a stylistic change is distinctly perceptible, heralding a new period in more than one respect.

Phase 1: Figurines originating from Levels 29 to 28

48. Upper half of a soot-blackened moulded plaque showing the bust of a female figure. The facial features are those of the Śuṅga C. P. figurines, including the rectangular hair-cut on the forehead. The tripartite head-dress consists of two side-projections of cloth-covered (?) hair tied with a ribbon, and of a middle bulge adorned with a full-blown lotus rosette from which two garlands are falling down. Vertical strokes on the left side of the plaque seem to indicate streamers hanging down from the respective bulge. The left ear is decorated with disc-shaped rings, the right with a heavier ear-jewel. Below a tight-fitting collar a string of pearls winds down between and around the full breasts. The extremely narrow waist shows traces of a girdle. The rather thin arms were bent in the elbows but the forearms are missing now. The back is unmodelled.

H. 6.5 cm. Colour: brown. No. So I 261.
FS. 3 I 4.2/Ca 15.1, H. 17.35 m.

Late Śuṅga C. P./Early Mitra. L.(30)/29

49. Fragment of a moulded plaque with depiction of a female bust similar to no. 48. The bulges of hair are decoratively engraved in lines. Instead of a central rosette a partially damaged flower-bud is topping the head. The pearl-necklace is three-lined but does not seem to wind below the breasts. The back is flat.

H. 6.6 cm. Colour: red-brown. No. So I 58.

FS. Stray find from eastern slope.

On the analogy of no. 48 the piece has to be dated to the Late Śuṅga C.P./Early Mitra period.

50. Moulded plaque showing a headless female with attendant of small stature on her right side. The woman is adorned with a torque and a loosely arranged pearl-necklace, a tight-fitting waistband, a broad girdle and armllets as well as anklets. The dress consists of a long garment arranged in folds from the shoulders down to the ankles. The cloth is of such thin a fabric that the impression of nudity prevails. The arms of the woman are lowered in a slightly bent position, the left hand touching the thigh, the right resting on the head of the attendant. He is a male wearing a loin-cloth, standing with right leg bent and hands carrying some object close to the right leg of the female. His head is shown upturned. The back of the plaque is flat. *For a complete specimen see A. G. Poster (1986: 98, fig.27); Gerd Kreisel (1989: fig.23).*

H. 10.5 cm. Colour: brown, red slip. No. So I 190.
FS. 3 II 1.3/Ca 18.65, H. 17.40 m. Early Mitra. L.29

a) Fragment of a plaque from same mould as no. 50 showing the legs of the female and the attendant.

H. 4.5 cm. Colour: brown. No. So III A 2392.

FS. 3 I 5.5/Ca 9.0, H. 17.25 m. Early Mitra. L.29

b) Fragment of lower half of plaque produced from same mould as no. 50 showing a female from waist to bottom. Attendant heavily worn, deep cut crossing his breast and the thighs of the woman.

H. 7.9 cm. Brown, red slip, whitish spots. No. So I 350.

FS 2 IV 16.7/Cc 4.4, H. 16.35 m (ditch). Early Mitra.

c) Fragment of a plaque produced from same mould as no. 50. From hips to ankles.

H. 5.2 cm. Colour: brown, red slip. No. So I 348.

FS. 2 IV 13.8/Cc 3.8, H. 16.70 m (ditch 30). Early Mitra

d) Fragment of a plaque made from same mould as no. 50. Much worn part from waist to bottom.

H. 6.4 cm. Brown, traces of red slip. No. So III A 2130.

FS. 2 V 4.0/Ca 19.5, H. 21.82 m. Out of context.

e) Fragment of a plaque made from same mould as no. 50. From waist of woman to bottom.

H. 7.3 cm. Brown, red slip, whitish spots. No. So III A 679.

FS. 2 V 2.85/Cc 13.05, H. 23.10 m. Out of context.

51. Small fragment of a plaque showing a female from waist downwards to feet. She wears a long dress arranged in folds from waist to legs, depicted so transparent as to awake impression of nudity. Left hand reaches down to girdle. Right arm and hand missing, but it was holding two fishes with heads up which are clearly visible. Below the fishes another fish is shown in rough outlines, placed as if swimming or lying aground. This is no speculation but verified by no. 51a. *Of this type several specimens are known. In a plaque preserved as a complete copy from an original mould in the collection of the Museum für Indische Kunst Berlin (no. MIK I 5957) the animal on the ground (or in the water) seems to be a crab.*

H. 6.0 cm. Brown, red slip, whitish spots. No. So I 365.

FS. 2 IV 12.5/Cc 6.7, H. 16.70 m. Early Mitra. L.29

a) Worn fragment of a plaque showing a female figure from thighs to bottom. On her right side two fishes. Below them another fish given in flat, rough outlines, depicted as if swimming or lying aground.

H. 6.0 cm. Colour: brown, red slip. No. So I 347.

FS. 2 IV 17.6/Cc 2.8, H. 16.60 m (ditch). Early Mitra

Phase 2: Figurines originating from Levels 28 to 26

Females

52. Female figure with both of her arms lowered to the sides. Lower half of face worn. On the forehead, a low rectangular cut in the hair is visible. The head-dress consists of a rare tripartite coiffure, the side-projections being tied by a ribbon with fluttering ends, the central bulge shaped by strands of hair simply extending upwards. The woman is adorned with spiral ear-rings, necklace, waistband, bracelets, and girdle of four rows of beads, holding up a short garment arranged in vertical folds.

H. 16.8 cm. Brown, red-slipped. No. So I 358.

FS. 2 V 17.0/Cb 9.6, H. 17.90 m. Mitra. L.27

53. Fragment of a standing female. Right hand lowered to girdle, left arm bent upwards, holding some object (flower?) in hand. Tripartite head-dress, hair parted in two carefully arranged lateral masses, on top previously a full-blown lotus, now chipped off. Upper part of the worn face encircled by a pearl-string. Round, concentric or spiral-shaped ear-rings, pearl-collar, double-

- stringed plain necklace, bracelets consisting of eight rings on the left and five on the right arm. Waistband and girdle scraped off. Folds of garment visible to the side of hips. Back flat. H. 6.7 cm. Brown, traces of red slip. No. So I 219. FS. 3 I 6.5–8.9/Ca 14.85–17.6, H. 18.68–17.80 m. Mitra. L.27
54. Worn fragment of a standing female as no. 53. Lower part of plaque missing. Figure not very clear, but perfectly similar in stylistic details although from different mould as no. 53. Full-blown lotus on top and better preserved girdle. H. 8.2 cm. Brown, red slip, whitish spots. No. So I 220. FS. Exactly the same as no. 53. Mitra. L.27
- a) Leg-part of a female figure of the type of no. 53. Anklets (double-rings?) at feet. Hem of garment below knees. H. 4.3 cm. Colour: brown. No. So III A 3305. FS. 2 IV 16.85/Cc 7.70, H. 17.15 m. Mitra. L.28/27
- b) Bust of a female of perfectly the same type as in no. 53. No differences. Object in left hand seems to be a flower. H. 4.7 cm. Brown, traces of red slip. No. So I 329. FS. 2 V 2.0/Ca 15.5, H. 18.40 m. Mitra. L.27
- c) Fragment from top to breast, as no. 54b H. 4.5 cm. Colour: brown, red slip. No. So III A 3192. FS. 2 V 1.1/Cb 6.4, H. 17.85 m. Mitra. L.27
- d) Lower part of a standing female of type of no. 53. Hem of garment below knees. Feet placed sideways. H. 7.1 cm. Brown, traces of red slip. No. So III A 3652. FS. 2 V 13.2–15.5/Cc 8.2–9.4, H. 18.05–17.95 m. Mitra. L.27
55. Standing female. Complete plaque of type of no. 53. Only specimen where face is clearly preserved. No rectangular blank in the hair above forehead. Eyes protruding, eyebrows and eyelids gaudily winding and broad. Triangular nose above small mouth. Lateral hair bulges joined with each other through three nearly horizontally placed strands of hair. Garment below girdle transparent. Anklets knobbed, feet placed sideways. H. 12.0 cm. Brown, red slipped, whitish spots. No. So I 327. FS. 2 V 19.0/Cb 1.5, H. 18.55 m. Mitra. L.27/26
- a) Mutilated fragment of a female of the type of no. 53. H. 8.0 cm. Colour: grey-brown. No. So I 290. FS. 2 IV 0.5/Cc 3.7, H. 22.20 m. Out of context.
- b) Standing female, exactly as no. 53. With the exception of the legs complete but much worn plaque. H. 10.2 cm. Colour: brown. No. So III A 678. FS. 2 III 18.77/Cb 16.60, H. 23.78 m. Out of context.
- c) Upper part of a female, type as no. 53. The bulgy object in the raised left hand preserves here, of all the specimens, clear outlines of petals. H. 5.2 cm. Brown, traces of red slip. No. So III A 986. FS. 2 V 19.4/Cb 14.14, H. 22.26 m. Out of context.
- d) Upper part of a female, type as no. 53. Weathered surface. H. 4.7 cm. Colour: light brown. No. So I 44. FS. Surface find.
- e) Upper part of a female, type as no. 53. Weathered surface. H. 6.2 cm. Colour: brown-red. No. So I 50. FS. Filling, north eastern tower.
- f) Head-part of a female. Type as no. 53. H. 4.0 cm. Colour: brown, red slip. No. So I 57. FS. Filling, north eastern tower.
- g) Leg-part of a female. Type as no. 53. H. 4.6 cm. Colour: brown, traces of red slip. No. So I 20. FS. Filling, Trench 1.

56. Plaque showing a standing female. Head missing. She wears a tight-fitting collar, a long, double-beaded necklace, arm-rings, bracelets and a one-stringed girdle. Her dress consists of a close-fitting short sari held by a waistband knotted in the middle from where three ends of ribbon are hanging down to the knees. The folds of the garment are slanting around both the legs. The feet are placed sideways. The right arm, slightly bent, is lowered, holding two (?) fishes on a chain (or in a net?) with the hand. To the side of this right arm a long arrow stands up (with presumably one-sided barb). The left hand holds a bunch of fruits. The back is flat.

As this interesting plaque is not moulded sharply enough the details are neither completely nor clearly recognizable. For a comparable piece and iconographical discussion see S. C. Kala 1980: fig. 44a, b, and pp.21f.

H. 8.0 cm. Grey-brown, red-brown slip. No. So I 331. FS. 2 V 12.1/Cb 3.9, H. 18.02 m. Mitra. L.27

a) Small fragment of leg-part of type as no. 56. H. 3.8 cm. Colour: brown. No. So III A 3558. FS. 2 IV 19.2/Ca 7.8, H. 18.95 m. Mitra. L.26

57. Fragment of a headless female from neck down to legs. Left arm is lowered, touching the girdle with the hand. Right arm worn. She wears a tight necklace consisting of pending beads and, perhaps, symbols. A second, longer necklace joins with the central jewel of the narrow waistband from which two ribbons hang down to the two-stringed girdle of pearl-shaped beads. The girdle holds the garment which covers the thighs with slanting folds on the right and vertical rows on the left, leaving the knees free. The back is unmodelled.

The two pieces of this fragment have been found in different spots, the lower one in a heap of ashes, but they fit together perfectly.

H. 9.5 cm. Brown, lower part blackened by fire. No. So I 264. FS. 2 V 15.8/Ca 17.4, H. 19.10 m. FS. 2 V 12.1/Ca 18.6, H. 19.27 m. Mitra. L.26/25

- a) Fragment of same type as no. 57. Female, waist to feet. H. 7.6 cm. Colour: brown. No. So III A 3254. FS. 2 IV 12.3/Cc 0.7, H. 18.10 m. Mitra. L.26
- b) Fragment of same type as no. 57. Female, hip to knees. H. 5.3 cm. Colour: brown. No. So III A 3659. FS. 2 V 15.4/Cc 3.0, H. 18.50 m. Mitra. L.26

Riders

There is a group of figures which are male riders from horses. All the specimens have been found in levels (28)/27 and should from the make of them be taken as tribal productions. As they are not unique pieces they had to be registered here from the point of representing a type; the more so as this type might have continued up to the Kuṣāṇa period.

58. Fragment of a male rider, made in the round. Hand-made body with arms broken off. In between hips and thighs a broad cavity indicates the spread of legs for sitting on horseback. The head of the rider is moulded separately on a lump of clay and added to the body afterwards. The face shows deep-set eyes with thick eyelids and a big triangular nose above sensual lips. The hair seems covered by a turban cloth and rises in a bulge on the left side of the head. It is either adorned with a diadem or bound artificially, giving the front a look of being ornamented. H. 6.9 cm. Colour: red-brown. No. So III A 3046. FS. 2 V 17.6–3 I 0.5/Cb 4.7–9.5, H. 18.15–18.00 m. Mitra. L.27

59. Fragment of a male rider with hand-made body in the round. Left arm broken off, the right one bent forward in horizontal position. Cavity between thighs. Moulded face much simpler than in no. 58. Eyes punched, mouth grooved like a horizontal stroke. Hair gathered up, in front adorned with a small diadem.

H. 7.5 cm. Colour: red-brown. No. So I 242.

FS. 3 I 8.6/Ca 12.6, H. 18.20 m. Mitra. L.27

a) Torso of a rider. Cavity between thighs extends as deep cleft up to the stomach.

H. 5.4 cm. Colour: brown. No. So III A 3345.

FS. 2 IV 13.5/Cc 2.0, H. 16.90 m. Mitra. L.28/27

b) Fragment of a rider. Blackened by fire. Tight collar (punched with circles?) around neck. Left arm lost.

H. 6.5 cm. Red-brown, blackened. No. So III A 2326.

FS. 3 I 6.2/Ca 10.0, H. 17.70 m. Early Mitra. L.28

c) Fragment of armless rider with moulded face as no. 58.

H. 7.2 cm. Colour: red-brown. No. So III A 3047.

FS. 2 V 19.2/Cb 9.0, H. 17.90 m. Mitra. L.27

d) Fragment of headless rider. Stumps of arms extended straight forward. Thighs spread.

H. 4.7 cm. Colour: grey. No. So III A 3519.

FS. 2 V 19.1/Cb 3.3, H. 17.70 m. Mitra. L.27

e) Fragment of a rider. Head and thighs chipped off, arms stretched forward.

H. 6.7 cm. Colour: red-brown. No. So III A 3700.

FS. 2 V 14.2/Cc 7.7, H. 17.90 m. Mitra. L.27

f) Torso of a rider. Long body. Cavity between hips damaged.

H. 6.6 cm. Colour: brown. No. So III A 3452.

FS. 2 V 17.3/Cb 9.5, H. 18.00–17.80 m. Mitra. L.27

g) Fragment of a rider. Surface weathered.

H. 5.1 cm. Colour: reddish. No. So III A 194.

Surface find.

h) Fragment of a rider with well preserved moulded face and turban. Bent arms broken off from the elbows.

H. 8.0 cm. Colour: reddish. No. So I 46.

FS. Filling north-east tower

60. Worn head of a rider. Face and turban as in no. 58.

H. 2.2 cm. Colour: brown. No. So III A 3274.

FS. 2 V 17.2/Cb 4.9, H. 17.97 m. Mitra. L.27

a) Partly mutilated head of a rider. Face of the type of no. 59.

H. 3.9 cm. Colour: brown. No. So I 12.

FS. Trench 1, E 36, H. 18.20 m. Stratigraphy uncertain.

Couples

61. Upper part of a plaque showing a couple set in architectural frame. Above, a caitya arch on flat ground is depicted. The nearly semicircular structure ends, in its outer contour line, pointed, or merges with a finial. At the lowest end the arch is slanting, perhaps just to join the partly wrong set door jambs. Below the arch seven wooden rafters with rectangular cross-sections are outlined. Under this portal a couple is, presumably, standing in the door opening. The two persons are given in some sort of three-quarter profile, turned to each other, holding hands. The man is on the left, the woman on the right side. The male's head-dress consists of a turban with lateral bulge, adorned with upstanding lotus buds (cp. male in no. 62). He wears a tight collar and arm-rings. The woman, even more defaced than the man, seems to have a cloth-covered hair-do and a long ear-pendant ending in a big jewel in the left ear.

H. 7.0 cm. Grey-brown, red-brown slip. No. So I 383.

FS. 2 V 5.0/Cc 2.7, H. 17.80 m. Mitra. L.27

62. Standing couple. Badly moulded plaque showing a female to left, a male to right. The woman stands frontally, the man is turned slightly towards her holding a twig in his left hand raised up to his breast (cp. no. 63, man to left). One or two leaves of the twig hang down to the left of the woman's head. Both the arms of the female are lowered to the girdle. She wears a tripartite head-dress consisting, so far as visible, of two voluminous lateral bulges topped with a flower(?). As the lower part of the faces and the surface of both the bodies are heavily disfigured by misleading folds in the clay, the garments and finer adornments can not accurately be described. The woman is presumably clad in a sari and wearing a short necklace, bracelets, girdle and anklets. As to the man, only the head is better moulded, wearing a rather unusual head-dress, similar to a turban adorned with three lotus buds (cp. the Mathura Museum's specimen MM 2383 in V. S. Agrawala 1984: pl. XI, fig. 36, p. 31, and MM 61.5227 in: R. C. Sharma 1971: fig. VIII).

H. 12.4 cm. Colour: red-brown. No. So I 297.

FS. 3 I 1.2/Cb 8.7, H. 18.00 m. Mitra. L.27

63. Small fragment of a plaque with remnants of a couple. Unlike no. 62 here the male is standing to the left, the woman to the right side. Again the woman is shown frontal and the male turned towards her. His right arm is bent, holding a twig in the hand. He seems to be clad in a dhotī, the preserved part of which is held by a girdle from which a loop (half of it broken away) and a tassel-like ribbon hang down. The woman, visible from back to right knee only, is adorned with a long necklace, a band around the extremely narrow waist and a three-stringed beaded girdle. Both arms are lowered, the left hand holding the shawl(?) which is floating over her legs, the right just spreading the fingers. The back of the fragment is unmodelled.

This piece is of poor quality but represents stylistic features to be met with only in the levels 27 to 25, as there are: flat carving, thin extremities etc.

H. 5.0 cm. Colour: red-brown. No. So I 296.

FS. 2 V 12.7–13.7/Ca 1.8–3.4, H. 18.40–18.05 m.

Mitra. L.27

a) Small weather-worn fragment of a plaque showing a couple. Man to left, woman to right.

H. 4.9 cm. Colour: brown. No. So III A 3241.

FS. 2 IV 14.0/Cc 9.4, H. 18.10 m. Mitra. L.26

b) Leg-part of a plaque with couple. Man to right, woman to left. Man turned right towards frontally standing female.

H. 3.2 cm. Colour: brown. No. So III A 3228.

FS. 2 V 14.1/Cb 11.5, H. 18.90 m. Late Mitra. L.25

c) Small fragment of a plaque with woman from a couple. Hands lowered to two-stringed beaded girdle. Fingers spread.

H. 4.2 cm. Colour: grey-brown. No. So III A 1684.

FS. 3 I 6.5/Ca 14.9, H. 19.50–18.68 m. Mitra. L.26

64. Weathered fragment of a hollow figurine of a couple. Made from two moulds for back and front respectively. Woman sitting on the left thigh of the man whose arm embraces her. His right hand seems to rest on her right thigh. Left hand of the female presumably touching her left hip. Details of dress and ornaments widely worn. He wears a longer necklace, she a narrow collar. Two strands of hair hang down on her back. The couple is sitting on a hollow pedestal mostly broken away now.

H. 10.0 cm. Colour: yellow-brown with whitish slip.

No. So I 259. FS. 3 I 5.2/Ca 7.4, H. 17.50 m. Mitra.

The find spot of no. 64 suggests a date as early as level 29, but in this case the author is rather sceptical about it. However this may be, the piece can not be earlier than Level 26 but belongs, of course, to Period III. A com-

1 *plete figurine similar to this type in the Mittal Museum, Hyderabad, is dated wrongly to the Kuṣāṇa period.*

a) Fragment of hollow pedestal with remains of legs of a couple as no. 64.

H. 7.0 cm. Brown, traces of whitish slip. No. So III A 3533.
FS. 2 V 9.45/Cb 14.5, H. 18.55 m. Mitra. L.26

65. Weatherworn head-part of a loving couple. Use of double-mould. Details of faces and head-dress too shabby to be accurately described. The male (left) was wearing a *jaṭā*-like coiffure decorated with small rosettes at the sides, the female's hair seems to have been curly.

H. 4.5 cm. Brownish, traces of white slip. No. So I 373.
FS. 2 V 10.3/Cc 12.8, H. 18.50 m. Mitra. L.26

Miscellaneous Figures

66. Mutilated plaque showing a male musician with a lute. Unfortunately the surface of the figure is abraded from face to foot-stand, so that the details are difficult to describe. The head-dress seems to consist of a turban with a flower-bud in the centre. Heavy and broad ear-pendants are visible above the shoulders. The man stands with left leg bent on a pedestal. The garment is wound around the right leg and covers the left only loosely. Between the legs two tasseled shawl-ends hang down. The man holds the right arm bent, the movement of the left one is not clear: it looks as if it is lowered along the body up to the elbow grasping a five-stringed instrument with the hand. A sharp line crossing the body indicates some sort of a sash hanging from the right shoulder to the left knee. The back of the plaque is flat. *Compare V. S. Agrawala 1955–56: fig. 6.*

H. 10.0 cm. Colour: brown, red slip. No. So I 351.
FS. 2 III 19.6/Cc 0.8, H. 18.80 m. Mitra. L.26.
Belonging presumably to L.27

a) Lower part of a plaque with leg-position as in no. 66. Figure standing on pedestal, left leg bent, two tasselled shawl-ends hanging down between the legs.

H. 5.6 cm. Colour: brown. No. So III A 2950.
FS. 2 IV 7.2/Be 17.0, H. 20.05 m. Mitra. L.27/26

67. Upper part of a plaque showing the bust of a male figure with hands in *añjali*. The man wears a turban, heavy ear-jewels and a tight collar. To the side of his head a lotus rosette with neatly depicted petals is visible, below it a flower-stalk(?) horizontally bent upwards at the edge of the plaque. Back flat.

H. 5.8 cm. Red, with whitish spots. No. So I 354.
FS. 2 IV 19.2/Ca 9.3, H. 18.55 m. Mitra. L.27/26

68. Fragmentary plaque showing head and bust of a male figure with a goat's head having projecting horns. The only adornment visible is a double-stringed necklace. The right side of the plaque is lost; as the upper edge is not curving down it is possible that more than one figure was depicted.

H. 4.5 cm. Colour: yellow-brown. No. So III A 2027.
FS. 3 I 2.0/Ca 18.3, H. 13.50 (in ring-well). Mitra. L.26

69. Fragment of a headless human figure shown from behind. The well-shaped back is naked up to the two-stringed girdle. The figure is obviously squatting. The left arm is bent, perhaps carrying something in the hands.

H. 7.2 cm. Colour: brown, sandy. No. So III A 3668.
FS. 2 V 17.5/Cc 2.2, H. 18.30 m. Mitra. L.26

Three-legged Figures

It is known that human terracotta figurines, not only in India, were occasionally provided with a third leg to serve as a support. In Sonkh a number of specimens of female and male figures with third leg has been found in the levels 28/27 to 26. Unfortunately, they are so much damaged and fragmentary that a stylistic classification is not possible.

70. Fragment of a three-legged female figure made in the round. Head, arms and right leg missing. Below the breasts the piece has been fractured. Around the hips traces of a girdle are visible. The third leg serves clearly as a support for the figure.

H. 9.1 cm. Colour: brown. No. So III A 3252.
FS. 2 IV 12.3/Cc 1.2, H. 17.85 m. Mitra. L.27/26

a) Fragment of a three-legged female made in the round. Head, arms and legs broken away. Deep navel-pit, traces of applied girdle.

H. 8.1 cm. Colour: brown. No. So III A 3537.
FS. 2 IV 10.6/Cc 1.5, H. 17.40 m. Mitra. L.28/27

b) Small fragment of a three-legged female figure. Strongly damaged.

H. 4.9 cm. Colour: brown. No. So III A 3232.
FS. 2 IV 12.5/Cc 3.5, H. 18.25 m. Mitra. L.26/25

c) Fragment of a three-legged figure: third leg with part of body. H. 6.4 cm. Colour: brown. No. So III A 3320.

FS. 2 IV 11.25/Cc 4.5, H. 17.85 m. Mitra. L.27/26

71. Mutilated torso of a three-legged male figure. Slim body with projection of third leg on back. Necklace consisting of grooves and a chain of holes.

H. 7.4 cm. Colour: dark grey. No. So III A 3049.
FS. 2 V 19.0/Cb 6.0, H. 18.05 m. Mitra. L.27

72. Torso of a three-legged male figure. Remains of genitals, projection of third leg.

H. 9.4 cm. Colour: brown. No. So III A 3676.
FS. 2 V 0.6/Cb 13.0, H. 18.97–18.80 m. Mitra. L.26

a) Torso of a three-legged male figure.

H. 7.0 cm. Colour: brown. No. So III A 3073.
FS. 2 V 3.6/Ca 18.4, H. 18.97–18.80 m. Mitra. L.26

Phase 3: Figurines originating from Levels 26 to 24

Miscellaneous Figures

73. Mithuna plaque showing a male and a female figure standing side by side. The female is the left-hand figure of the pair. While the man is holding the woman with a firm grip of his left hand at her left arm she is caressing his chin with her right hand. This is done by her with a bodily gesture of seemingly coy refusal. She has curly hair and is adorned with ear-rings and anklets. The crosswise arranged ribbons with central jewel below her breasts seem to hold the artful wide-meshed apron which covers her body from hips to knees. The man is adorned with a double-stringed long necklace and heavy bracelets: the head-dress remains unclear. He is clad in a dhotī fastened round the waist and covering the legs in heavy vertical folds, in front of which two fillets of different length are hanging down from the knot. Below the left knee the garment is taken up triangularly, leaving a part of the leg free.

The two parts of this plaque have been found in different spots but they fit together perfectly.

H. 14.6 cm. Colour: red-brown. No. So I 208.
FS. 3 I 9.8/Ca 8.8, H. 19.15 m.
3 I 5.5/Ca 15.5, H. 19.50 m. Late Mitra. L.25

74. Head and bust of a male figure on upper half of a plaque. The facial features, as narrow forehead, horizontal eyebrows, protruding eyes and tapering lower jaw, appear rather strange. The head-dress is a combination of hair-do on the one and crown(?) on the other side. The figure wears ear-rings, a flat necklace and armlets. The hand of the bent right arm holds(?) a bunch of flowers(?) above which a lotus rosette is filling the free space. The back of the plaque is flat.

H. 7.5 cm. Grey-brown, half-side red-slipped.
No. So I 224. FS. 3 I 2.4/Ca 17.5, H. 18.75 m.
Late Mitra/Early Kṣātrapa.

The find spot is on the rim of the ring-well of Level 26, not existing anymore in L.25, but stylistically one would prefer an origin in L.25/24, i.e. a few decades later.

When describing this fragment we had no access to the original object. Therefore a number of points remain undecided. It may be helpful to expose a few ambiguous details: 1) The head-dress seems to be intentionally divided in crown(?) and matted hair; 2) the central projection does not seem to be just a turban bulge. To see in it the head of a snake the body of which is winding on part of the head (left) is certainly very speculative; 3) the ear-rings are different; 4) the armlets show varying designs; 5) the position of the right hand and the connection with the flower bunch(?) is not clearly visible.

75. Upper part of a female. The face with its full, round cheeks is dominated by the straight, vertical nose, the horizontal eyebrows, protruding eyes between closed eyelids, and an extremely narrow forehead. The coiffure consists of matted locks parted in two halves and combed in separate directions. On the right side of the face a strand of hair is falling to the shoulder. It is not clear if the ear-rings differ but it looks like it. A two-stringed necklace is loosely hanging from the neck. *In the author's opinion the female was four-armed. The left two arms are broken away, the right ones are parting in the shoulder: the back arm is lowered beside the breast, the front arm extends diagonally across the body and seems to embrace something that she is pressing against her left shoulder. One of the left arms might have had supported this action. The author suggests to see in this figure the earliest depiction of the Durgā Mahiṣāsūramardīnī because the object on the left shoulder looks like an animal's head with an open snout on the extreme edge of the piece. In case the interpretation is right, this would be a version preceding the Kuṣāna form where the goddess is strangling the Mahiṣa's neck with her left front arm only.*

H. 7.1 cm. Colour: brown. No. So I 215.
FS. 3 I 0.5–2.0/Ca 9.5–11.5, H. 20.15–19.85 m.
Early Kṣātrapa. L.24

76. Lower part of a Yakṣa figure from waist to bottom. Made in the round, presumably using two moulds. The Yakṣa is standing frontal on a low pedestal, the right knee slightly bent, the right hand resting on the thigh, the left one touching the girdle. The pot-bellied figure is clad in a dhotī reaching down to the ankles and fastened with a girdle from the knot of which two fillets of different length dangle between the legs. There is a confusing line below the knees suggesting the hem of the garment, but there seems to be no doubt that the dhotī ends in the bulgy folds at the ankles. At the back the buttocks are shown under the continuing ribbon of the girdle.

H. 10.1 cm. Colour: light-brown. No. So I 313.
FS. 2 V 13.8/Cb 15.0, H. 18.90 m. Late Mitra. L.25

77. Fragment of a standing female made in the round by use of double-mould on a solid core of clay. Weatherworn part from waist to legs. Folds of garment to the side of left leg. Traces of a pearl-chain along hipline and flexure of the groin. Right arm lowered, hand holding or touching an unidentifiable object (or person). On the back, buttocks, legs and part of left arm are preserved. The figure was completely white-slipped.

H. 6.1 cm. Grey-brown, white slip. No. So I 372.
FS. 2 V 6.7/Cc 3.3, H. 18.85 m. Late Mitra. L.25

a) Fragment of human figure made by double-mould on solid core of clay. Part of lower legs.

H. 4.9 cm. Grey-brown, white slip. No. So III A 3457.
FS. 2 V 0.5/Cb 12.5, H. 18.85 m. Late Mitra. L.25

b) Weathered fragment of a couple made by double mould on solid core of clay. Legs only. Male figure to the right of female. Low pedestal.

H. 7.1 cm. Colour: brown. No. So III A 2954.
FS. 2 V 8.5/Cb 5.3, H. 19.45 m.

Late Mitra/Early Kṣātrapa. L.24/23

78. Headless "Winged Female". Hand-made. The body has no arms and no legs, it ends flat and rounded below the waist. Where the arms should begin the clay is shaped in wing-like projections bent backwards. That the depiction of wings is intended is indicated by three horizontal strokes on the back, crossing a long vertical line along the spine. The break on the neck shows that the figure had a head. Above the breasts two sharp holes mark a perforation of the piece. One of the holes is visible penetrating into the back. A third hole takes the place of the navel. Assuming that all the three holes were perforating the body, this piece should have been used in hanging position.

H. 6.9 cm. Colour: red-brown. No. So I 263.
FS. 2 V 12.8/Cb 5.7, H. 19.55 m.

Early Kṣātrapa. L.(24)/23

In the end of Period III first specimens of "Nude Dwarfs" appear. As this type is continuing for some time, the whole group is dealt with after Period VIII as Terracotta Appendix 1.

1



48



49



50



51

1



58



59



60



61



62



63



64



65



66



67

1



68



69



70



71

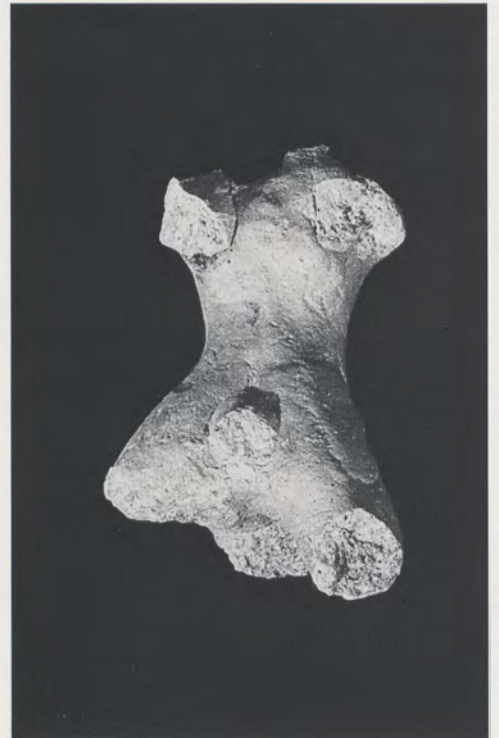

72



73



74



75



76



77



78



78 R

Period IV. Figurines from Levels 24 to 22

The levels 24 and 23 in the excavations at Sonkh contained structural remains and instructive finds of the Kṣatrapa period of Mathura. They represent a culture which is a mixture of indigenous (Indian) and foreign (Śaka) elements, best shown by the appearance of Kṣatrapa coins along with those of Rāmadatta of the Datta dynasty of Mathura, by the intermingling of Indian and foreign pottery shapes and by a seal impression carrying the name *Anāṅgabala* written twice, once in Brāhmī and once in Kharoṣṭhī characters on the same lump of clay.

While it looks as if the Kṣatrapas were quite ready to conform with new conditions of religious life and art, it is highly interesting to watch their perseverance in the faith of Mother Goddess and, along with it, in the preservation of the customary and presumably traditional figuration of Her which is quite different from all Indian Mother Goddess figurines known up to this period. The material from Sonkh comprises:

1. Fragments of rather crudely made but stylistically unmistakable female figures coming from and belonging to votive tanks equipped with seated Mother Goddesses (nos. 79–85), and
2. Fragments of seated solitary figures of a more sophisticated artistic mode (nos. 86–88).

The votive tank of no. 79 shows how the single figures of group 1 were originally placed in such a vessel. But this tank is of even greater importance. Its significance lies in the assemblage of the figures. Preserved are four females. Between the third and the fourth figure from the left the basic remains of a fifth one are clearly visible. On the missing opposite side two further women were seated. Therefore this tank contained at least seven *Mātrikā* figures of the same type. It is not possible to decide whether the completely missing fourth side of the vessel was empty or occupied by another figure (sitting opposite the second woman from the left), but if so, then the total number of figures would be eight. As there is no doubt, whatsoever, that the women represent a group of Mother Goddesses, the object, therefore, has to be identified as a *saptamātrikā* or *aṣṭamātrikā* tank for domestic worship. A part of the *pūjā* must have consisted in placing food in each bowl of the goddesses. This representation reminds one involuntarily of the late-vedic food offerings to the gods.

The more artistic type of Mother Goddess came to light only in layers of the second phase of level 23 belonging to the end of the Kṣatrapa period in Sonkh. It is undoubtedly a later product than the more tribal Mother Goddesses of the votive tanks found in the earliest Kṣatrapa layers of levels 24/23. Although of poor artistic merits, the style is, as the specimens show, unmistakable and each figure is, regardless of slight variations, made true to type as discussed in the descriptions.

Judging from the Sonkh materials, at least two elements of this Kṣatrapa type of terracottas are not only new in the realm of Mathura art but contributed considerably to the appearance of the subsequent Kuṣāṇa terracotta figures as well. For one thing there is the production of larger figures seated on or ending in a stand. But among all the strange elements in this Kṣatrapa type the punctured eyes with the piercing look seem to have made the strongest impression on the contemporary Mathura artists, because from now on the faces of the males and females depicted in terracotta take up generally and for long the well-known punctured eyes. They are subdued or missing only in the “classical” or more sophisticated Kuṣāṇa terracotta faces from Mathura. It is, therefore, not surprising to find these punctured eyes already with terracotta figures from the earliest Kuṣāṇa level in Sonkh, the female, the male figures and the gods and goddesses too.

The male figures from the levels 24/23 (nos. 92–95) are made true to the female type with regard to the shape of face and the ribbon on the head. Three-legged figures, female as well as male, continue to occur as in earlier levels. The most interesting piece of the miscellaneous figures is no. 91 which has the shape of a brick showing a more than two-armed figure. The author feels safe to identify it as that of *Durgā Mabiṣāsūramardīnī*, i.e. as one of the earliest depiction of the goddess at all (cp. no. 75).

Figures of Mother Goddess

79. Four Mother Goddess figures in a votive tank. All of them are seated and have a bowl in their lap. Although the arms are broken off, the remains of a child in the left arm of two of the hand-modelled figures show that they were all depicted in the same way. Regardless of the tribal shape and the poor artistic merits of the figures they represent an unmistakable style of their own: The faces are roundish, the nose and the eyes are applied to the face in a most simple way. A ribbon is attached to the forehead joining behind the neck. The protruding ears wear undecorated ear-discs. Unusual is the disc-like ornament hanging out from under the frontlet. A broad necklace winds between the breasts ending in a cylindrical box or pendant. The breasts show a sharp prick each. All the figures wear a girdle formed by a row of discs. The legs are fixed on the bottom of the tank as far as preserved. This position explains why single figures originating from such votive tanks, but found separately, are mostly missing the legs. At the back, the head-band continues and frames the hair which is marked by vertical scratches. The lower back of the figures joins with the wall of the tank.

The tank character of this object is going to be described under Votive Tanks.

L. 26.0 cm. H. 14.8 cm. Red slip, whitish spots.

No. So I 325. FS. 2 V 1.3/Cc 5.5, H. 18.85 m.

Early Kṣatrapa. L.24

80. Mother Goddess from a votive tank. Hand-modelled. Facial features same as in figures of no. 79. Arms broken away. Head-band and necklace punched in a row. Plane ear-discs. Traces of a child on stomach and lap. Girdle chipped off. Legs missing. Horizontal cut in the lower back where the figure was joining the wall of the tank.

H. 11.1 cm. Colour: brown. No. So III A 3560.

FS. 2 V 4.6/Cc 0.8, H. 18.95 m. Early Kṣatrapa. L.24

81. Fragmentary figure of Mother Goddess from a votive tank. Type same as in nos. 79 and 80. Arms broken off. Traces of head-band. Plane ear-discs. Necklace adorned with a row of punctures. Breasts show a sharp prick each. Cylindrical pendant likewise showing a hole. Child as well as girdle missing. Horizontal break in the lower back where figure joined the tank.

H. 10.4 cm. Colour: brown. No. So III A 3561.

FS. 2 V 5.2/Cc 0.6, H. 19.00 m. Early Kṣatrapa. L.24

82. Mother Goddess with child from a votive tank. Hand-made type as nos. 79–81. Head-band and necklace undecorated. Disc-like ornament under frontlet. Breasts pricked. Left arm holds a clumsy looking child stretching its body and legs across the stomach of the goddess. Right arm damaged. Of the girdle a few discs are preserved. Legs broken off. On the lower back a horizontal break where figure was joining the tank.

H. 13.2 cm. Colour: brown. No. So III A 2908.

FS. 2 V 7.8/Cc 2.2, H. 19.20 m. Early Kṣatrapa. L.24

a) Fragment of a hand-made figure of Mother Goddess. Head, arms and legs broken off. Remains of necklace and cylindrical pendant. Girdle formed by a row of plane round discs. Horizontal break on lower back.

H. 11.4cm. Colour: grey-brown. No. So III A 3104.

FS. 2 V 4.8/Cc 1.7, H. 19.00m. Early Kṣatrapa. L.24

b) Fragment of a hand-made figure of Mother Goddess. Headless and armless bust. Necklace with row of punches. Breasts pricked. Distinct navel.

H. 8.2cm. Colour: brown. No. So III A 3565.

FS. 2 V 7.5/Cc 1.0, H. 19.05m. Early Kṣatrapa. L.24

c) Fragment of a hand-made figure of Mother Goddess from waist to thighs. Left hand (or leg of child?) on hip. Girdle of plane discs.

H. 4.5cm. Colour: brown. No. So III A 3584.

FS. 2V 8.0/Cb 13.5, H. 19.10m. Early Kṣatrapa. L.24

83. Hand-made figure of Mother Goddess from a votive tank. Somewhat better in make than nos. 79 to 82. Mouth, nose and eyes properly applied on face. Round ornament on forehead. Ribbon around head. Left ear chipped off. Single disc adorns front of neck. Necklace carefully stamped with row of punches, ending in the cylindrical pendant below breasts. Navel. Girdle of plane discs from hip to hip. Remains of left hand or leg of child on left hip. Legs missing. At the back the head-ribbon frames the hair dangling down to the shoulders. Part of lower back which joined the wall of the tank is broken off.

H. 15.4cm. Colour: brown, red slip. No. So I 357.

FS. 2 V 5.4/Cc 0.8, H. 19.05m. Early Kṣatrapa. L.24

84. Weatherworn torso of a hand-made and carefully shaped figure of Mother Goddess. Plain necklace with traces of cylindrical pendant. Navel. Remains of a girdle of discs. Break in lower back.

H. 10.5cm. Colour: grey-brown. No. So III A 3105.

FS. 2 IV 10.0/Ca 5.5, H. 21.35m. L.22

Although found in a later level the figure is of the type of no. 83.

85. Fragmentary figure of Mother Goddess with child. The trunk is hollow and wheel-made, all other parts handiwork and solid. The left leg, both the lower arms, the right breast and nearly all of the back are broken off. The right leg is bent, indicating a seated position of the goddess. The heavy-built head on the badly proportioned bulky figure is dominated by a massive nose with broad wings above tight-lipped mouth. Under thick eyebrows the eyes are incised in slightly slanting ovals. On both sides of the head long-stretched ears are protruding, adorned with simple ear-discs. Above the low forehead an ornamented head-band is laid around the head continuing at its back as an undecorated ribbon ending in a triangle. A plain necklace, now partly chipped off, hangs down between the breasts. The preserved left breast is shaped hemispherical, looking rather fertile with its strong nipple. In the left arm a small child is placed stretching the arms. The flexion of the leg as well as the size indicate that this figure did not form part of a votive tank.

H. 25.0cm. Colour: brown, red slip. No. So I 318.

FS. 2 V 7.2/Cb 16.6, H. 19.55m. Kṣatrapa. L.23

86. Mother Goddess figure with child. Hand-made and shaped in the round. The head shows the characteristics of a special type: The face with its receding cheeks, the distinctly small mouth, the dominating big nose merging at its root into the angular but unmarked eyebrow lines, the deep-cut cavity of the eyes giving prominence to the eyeball the pupil of which is marked by a sharp prick, and finally, the broadly modelled ears adorned with plain ear-discs. A ribbon is laid along the forehead and joins behind the

head in a wavy fashion at the neck. As plain as the frontlet is the necklace hanging down between the small breasts only the right one of which is preserved. A navel is hinted at by a shallow and round depression. The child, clumsily placed on the left arm, shows no distinctive features. The missing legs permit a look at the figure's stand which is, seen from the reverse, finishing up the plane back.

H. 21.5cm. Colour: brown, traces of red slip.

No. So I 239.FS. 2 V 7.3/Ca 3.0, H. 20.90m.

Kṣatrapa. Phase 2 of L.23

a) Torso of a seated woman. Plain necklace between tiny breasts.

H. 13.3cm. Colour: brown. No. So III A 2759.

FS. 2 V 6.0/Cb 14.3, H. 20.50m. Kṣatrapa. L.22

b) Weatherworn bust of a female figure. Facial features as no. 86. Ribbon on forehead, joining between shoulders.

H. 11.6cm. Brown, traces of red slip. No. So III A 654.

FS. 2 C 0.4/Cb 12.8, H. 25.75m. Out of context.

87. Head of Mother Goddess figure of the same type as no. 86. Receding cheeks, dominating nose, incised eyes and low forehead with ribbon around head.

H. 6.8cm. Colour: brown, traces of red slip.

No. So III A 2458. FS. 2 V 15.0/Cb 11.7, H. 19.70m.

Kṣatrapa. L.23

88. Head of Mother Goddess figure as no. 86. Head-band chipped off from forehead but preserved at the back. Receding cheeks. Sharply incised eyes, extremely small mouth. Right ear with plane ear-disc.

H. 6.8cm. Colour: brown, red slip. No. So I 269.

FS. 2 V 12.3/Cb 0.25, H. 19.90m. Kṣatrapa. L.23

89. Head of Mother Goddess figure as no. 86. Weatherworn surface. Head-band chipped off. Facial features as in nos. 86 to 88. Left ear with plane ear-disc, right one missing.

H. 6.8cm. Colour: brown, traces of red slip.

No. So III A 2048. FS. 3 I 1.0/Cb 3.2, H. 20.75m. L.21

90. Headless figure of Mother Goddess. A clumsy version of no. 86. Right arm bent forwards but broken off in the elbow. Plain necklace hanging down between the breasts. Ugly child in left arm, left hand rests on the thigh. Legs bent in the knees. The figure is supported by a stand extending the back. Feet missing.

H. 14.6cm. Colour: red-brown. No. So III A 2951.

FS. 2 V 7.3/Cb 16.8, H. 19.55m. Kṣatrapa. L.23

a) Headless fragment of a female seated on a stand. Necklace decorated with horizontal strokes. Legs broken off. Rectangular stand in extension of the back as in no. 86.

H. 15.1cm. Colour: red-brown. No. So III A 1667.

FS. 2 IV 2.2/Cb 16.2, H. 21.80m. L.(22)/21.

Although found in later level type originates in Kṣatrapa-L.23.

Miscellaneous Figures

91. Upper part of a plaque in the depth of a brick showing human figure in indistinct action. Stylistically, the piece has the type of face with receding cheeks and extremely low forehead originating in the Kṣatrapa-level 23. As the right shoulder is chipped off the identification of the figure is made rather difficult. On examination of the original the author offers the following interpretation. *The figure is a female on the ground of the round ornament on the forehead and a number of armllets on the right front arm crossing the chest horizontally. The figure is four or six-armed, it is Durgā Mahiṣāsura-mardini. The second right arm is lowered to the (broken off) back of the buf-*

1 *falo. To the right, the head of the animal is stretched upwards, the horns bent backwards covering the hand of the out-stretched right arm of the goddess. The position of this arm indicates the same way of strangling the Mahiṣa as described in no. 75. Regrettably, the identification of both these pieces is not flawless. Otherwise they would undoubtedly represent the two earliest depictions of this goddess.*

The unusual depth of the plaque gives the impression of a terracotta brick made for the purpose of ornamentation, possibly as part of a door frame or a similar structural element.

H. 8.6 cm. Colour: clay, with traces of red slip.

No. So I 292. FS. 2 V 3.7/Cc 9.15, H. 20.25 m.

Late Kṣatrapa. L.22

92. Torso of a drummer. Hand-made male figure in presumably seated position with a drum under left arm. Right arm broken off. Necklace ornamented with vertical indentations.

H. 6.9 cm. Colour: red-brown. No. So III A 2859.

FS. 2 V 1.5/Cb 0.1, H. 19.70 m. Kṣatrapa. L.23

93. Mutilated male figure. Hand-made. Arms and legs broken off. Triangularly protruding nose in a slightly upturned face with receding cheeks. Mouth indented as a horizontal stroke. Eyes incised. Ears adorned with plain ear-discs. A ribbon above low forehead is laid around the head. Undecorated necklace applied in full, i.e. even behind the neck. The same is valid for the long ribbon hanging from the left shoulder to the right armpit and returning on the back to the shoulder (*upavīta?*). The right nipple on the chest is of the small size as used on man's figures. The body is slightly pot-bellied. The back of the figure is elongated into a stand showing that the man was depicted in a seated position.

H. 23.3 cm. Colour: red, carbonized core.

No. So I 202. FS. 3 I 1.2/Ca 13.0, H. 20.70 m.

Late Kṣatrapa. L.23/22

a) Fragment of the back of a male bust. Hand-made. Head-band and necklace exactly as in no. 93. Without ribbon.

H. 10.4 cm. Colour: red-brown. No. So III A 3129.

FS. 2 IV 9.8–19.5/Ca 19.5–Cb 0.5, H. 21.80–21.50 m.

L.21. Type originating in Kṣatrapa-L.23.

94. Bust of a male figure. Long, pinched nose merging with the low forehead. Details on head worn. Incised eyes. Traces of a moustache. Plain ear-discs in sideways protruding ears. Necklace looking like a folded ribbon. Small nipples. Both arms broken off.

H. 12.7 cm. Colour: red-brown. No. So III A 1668.

FS. 2 IV 18.2/Cc 4.7, H. 20.30 m. Late Kṣatrapa. L.22

95. Head of a male figure with moustache. Receding cheeks, dominating nose merging with the eyebrows, incised eyes in slanting ovals, broadly modelled ears with traces of ear-discs. Above low forehead a double (?) ribbon around the head. Traces of ornament on the upper edge and in the centre. The head was turned upwards.

H. 9.5 cm. Red-brown, core carbonated. No. So I 302.

FS. 2 IV 2.5/Cb 0.65, H. 21.70 m. L.(22)/21

Although found in a later level type originates in Kṣatrapa-L.23.

Three-legged Figures

96. Fragmentary female figure without head, right arm and legs. On back projection of a third leg placed as support. Except plain girdle no ornamentations. Remains of lowered left arm.

H. 8.0 cm. Colour: brown. No. So III A 3580.

FS. 2 IV 0.5/Cc 1.4, H. 19.30 m. Kṣatrapa. L.24/23

97. Headless seated female. Arms broken off. Applied breasts showing a sharp prick each. Traces of a ribbed necklace. Large navel-pit. In front a girdle ornamented with two horizontal rows of buttons. The preserved right leg is bent indicating the seated position of the figure which is supported by a strong third leg. Above front legs an apron-like projection.

H. 9.4 cm. Colour: red. No. So III A 1672.

FS. 2 V 7.3/Ca 5.3, H. 21.35 m.

L.22 or first phase of L.21. Late Kṣatrapa or Early Kuṣāṇa.

98. Torso of a male figure. Undecorated nude body shows pot-belly with deep navel. Remains of genitals between spread thighs. Strong third leg projects as support.

H. 7.6 cm. Colour: red-brown. No. So III A 2709.

FS. 2 IV 12.5/Cb 2.5, H. 21.70 m. L.(22)/21.

Transition period from Kṣatrapas to Kuṣāṇas.



79



79 R

1



80



81



82



83



83 R



84



85



86



86 R



87



88



89

1



90



91



92



93



93 R



94

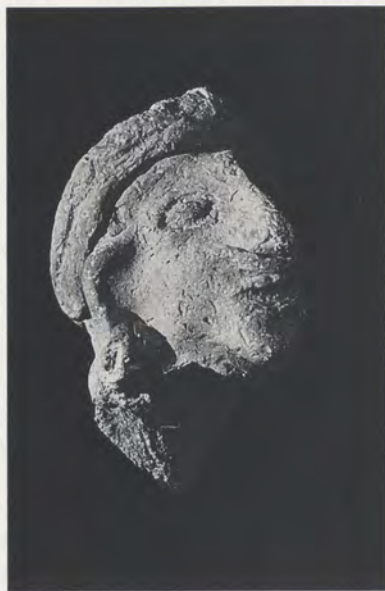

95a



95b



96



97



98

1
Period V. Figurines from Levels 22 to 16

The Levels 22 to 16 cover the time from the beginning to the end of the Kuṣāṇa period. The number of usable terracotta figurines and fragments of them, assignable to this period, sum up to 87. With the exception of five pieces all the objects hail from stratified spots in their respective levels. The remaining five have been found in later levels or were registered as stray finds. They could be allotted to the one or the other level of this period.

Technically the Kuṣāṇa figurines represent all the methods of terracotta productions known from older times. There are the free-standing and hand-made figures, the moulded plaques and the figures in the round made from two moulds. Conspicuous is the presence of a large number of a new type of big seated figurines, either solid or hollow. Judging from the extent of finds of fragments, i.e. of legs, arms, and bodies of such voluminous figures (not listed here) they must have existed in considerable quantity. The invention of such big types goes back to the Kṣatrapas, but the Kuṣāṇas made them their own way, placing the seated figure on a square or round base. The artistic quality of these products is, mostly, rather poor; they represent, nevertheless, a stylistic type of their own.

With the exception of a more limited, rather sophisticated group of figures or plaques the exterior look of the Kuṣāṇa terracottas is dominated by the technique of carving most of the details into the surface of the clay by more or less deep incisions and pricks. This technique has in part been taken over from the Kṣatrapas, especially the impressive pricked pupils of the eyes lending the face such a piercing look. The same can be observed with the ears, often protruding straight sideways and being mostly punctured on the upper or lower outer edge of the flat-spread and long-drawn ear (e.g. nos. 100, 102–107). The fondness to incise details and to prick eyes and breasts did not even stop at moulded plaques (e.g. nos. 119–129; 132–133) getting their finishing touches after coming out of the mould.

The type of “sophisticated” or “typical Kuṣāṇa” terracottas (compared with stone sculptures of the time) is best to be seen in the hollow plaques (nos. 146–147). Such pieces tempt to raise the query why the bulk of terracotta figurines of this period were produced in such a low quality compared with that of the stone products.

From the *iconographical* point of view the Kuṣāṇa terracotta finds from Sonkh represent a manifold, but still limited number of gods and goddesses, as there are Mother Goddess, Durgā, Durgā Maḥiṣasuramardīnī, Kubera, Yakṣa, and Nāga. Dominating are the plaques with the depiction of the goddess Durgā in the act of killing the buffalo-demon Maḥiṣa (nos. 116–126) in the well-known mode of the Kuṣāṇa period: the buffalo is standing on his hind legs with head uplifted in front of the goddess and body stretched across her thighs. Durgā herself is pressing down its spine with her right lower hand and grabbing its head by the throat. In this scenery the goddess is either four or six-armed. In the four-armed version the upper two hands carry dagger and shield or shield and short-shafted trīśūla with prongs turned upwards. When six-armed, the highest hands are holding a garland. The plaques and fragments of the Durgā as Maḥiṣasuramardīnī from Sonkh show a chronological development of this iconography which ends in no. 124. There the goddess is depicted with the short-shafted but now activated and lethal weapon in the upper hands ready to thrust it down into the body of the Maḥiṣa. Judging from no. 123 where the goddess holds a vajra instead of a trīśūla in her right upper hand, the weapon in no. 124 might as well be a vajra (see H. Härtel, Early Durgā Maḥiṣasuramardīnī

Images – A Fresh Appraisal, in the press). It is interesting to note that a number of the Sonkh plaques hail directly from the Apsidal Temple no. 1 or its immediate surroundings. Not in the attitude of killing the Maḥiṣa but as a standing two-armed goddess with dagger and shield Durgā is shown in no. 129.

The next frequent remains of a god are those of Kubera who was exclusively depicted as a big seated figure made in the round (nos. 135–140, and heads nos. 104–106). Kubera is two-armed and holding, as a rule, a cup and a longish object, presumably representing a mongoose purse. Quite a number of fragments from bodies (nos. 162–183 and 184–185) might be parts of such Kubera figures.

For the Boyish Figures of nos. 156–161 the necessary has been said below in the introduction to this group.

Human Heads

99. Head of a female(?) figure. Hand-modelled, solid core. Thick but short lips set in a deepening merging into the otherwise plump cheeks. Nose partly damaged. Characteristic features are the large open eyes with pupils denoted by pierced holes and the deeply incised double eyelids and eyebrows. The hair is elegantly parted in two flat bulges framed by bead-strings. The parting is decorated with a chain of jewels increasing in size towards the forehead. The ears are adorned with large circular ear-rings ornamented with two rows of holes. The back of the head is flattened, showing hair by incised lines.

H. 13.5cm. Colour: brown, traces of red slip.
No. So I 260. FS. 2 V 14.8/Cb 17.8, H. 20.20m.
Early Kuṣāṇa. L.22

100. Female bust. Hand-modelled, carbonized core. Eyeballs strongly pierced. Eyelids and eyebrows deeply incised; the latter joining in an uninterrupted line. Small mouth in a deepening. Hair-strands laid sideways, framing the forehead. In the middle an ornament shaped like a double-comb. Above it, head-dress (or crown?) mostly damaged. In the ears, marked by a perforation, broad pendants are hanging. Two almost horizontally arranged necklaces reach from shoulder to shoulder and rest on the breasts only the left one of which is preserved. The upper necklace consists of a row of plane discs while the lower one is shaped as a garland. Back smooth, slightly rounded.

H. 11.2cm. Colour: red-brown. No. So I 251.
FS. 2 V 20.0/Cb 15.0, H. 20.80m. Early Kuṣāṇa. L.22/21

101. Female head. Hand-modelled, solid. Half of the face and most of the hair lost. Face shows plump cheeks, thick-lipped mouth, strong nose and incised eyelids and eyebrows around sharply pricked eyeballs. Below the browline of the right eye traces of hair are visible. The incisions are altogether more carefully done than in nos. 99–100. A number of curls remain of the hair. Several small holes on the head indicate that an ornamental application was fitted. Back smoothly rounded.

H. 12.2cm. Colour: brown, red-slipped.
No. So I 304. FS. 2 V 9.9/Cc 0.3, H. 20.70m.
Early Kuṣāṇa. L.21

102. Male head. Hand-modelled, carbonized core. Weatherworn face with presumably incised eyelids. Above low forehead a wreath of crown with round jewel in centre. Ears adorned with cylindrical pendants. Back smoothly rounded.

H. 6.9cm Colour: red-brown. No. So I 291.
FS. 2 V 2.3/Cc 5.8, H. 20.28m. Early Kuṣāṇa. L.22

a) Weatherworn head of a male. Facial features and head-dress similar as in no. 102.

H. 5.2cm. Colour: brown. No. So I 81.

FS. 2 I 16.0/Bd 15.5, H. 20.0m (Trench 4).

Early Kuşāṇa. L.22

b) Weatherworn male head. Punctured beard. Right ear-lobe shaped as a loop. Central ornament in incised head-dress.

H. 11.5cm. Colour: brown. No. So III A 2895.

FS. 2 IV 14.1/Ca 17.1, H. 21.40m. Early Kuşāṇa. L.22

103. Small mutilated human head. Hand-modelled. Eyebrows and eyelids incised. Pupils denoted by pierced holes. Nose showing nostrils. Thick-lipped deep-set mouth.

H. 4.2cm. Colour: yellow-brown. No. So III A 1349.

FS. 2 V 5.6/Ca 15.8, H. 21.20m. Early Kuşāṇa. L.22/21

104. Mutilated male head with moustache. Hand-modelled, core carbonized. Eyebrows and doubly edged eyelids incised, eyeballs protruding, pupils denoted by pierced holes. Mouth partly surrounded by curved moustache. Left ear broken off, right one damaged. Above low forehead vertically arranged strands of hair with traces of a fillet. Upon the head a hollow space is visible in the damaged hair-part. As the back is rough and convex in shape the head served possibly as decoration of a vessel.

H. 8.7cm. Colour: brown, traces of red slip.

No. So I 241. FS. 2 V 8.2/Ca 9.8, H. 21.65m.

Kuşāṇa. L.21

105. Head of a man with moustache. Hand-modelled. Eyebrows, eyelids, (traces of) ear-rings and the upturned hair altogether marked by sharply incised lines. Eyes arranged slantingly, pupils in protruding eyeballs denoted by pricked holes. Moustache indicated by three horizontal strokes each on both the cheeks. From the mouth downwards a semicircular incision presumably indicating a double-chin. Hair above low forehead is given in simply incised upright strokes. Broadly projecting ears with a pierced hole on the upper edge. Similar holes, but doubled, to both sides of the forehead. Back mutilated. Tenon for the insertion of the head into the body sticking out of neck. For the type of figure see no. 135.

H. 11.2cm. Colour: grey-brown. No. So III A 2582.

FS. 2 V 3.0/Cc 0.5, H. 20.70m. Kuşāṇa. L.21

106. Male head with moustache. Hand-modelled, core carbonized. In all facial features similar to no. 105. In addition an incised horizontal line, ending in a sort of small bulges, is visible above the upturned hair. The holes in the ears are here accompanied by a single prick at the root of the nose. For the type of figure see no. 135.

H. 11.2cm. Colour: red-brown. No. So I 285.

FS. 2 III 17.5/Cb 6.7, H. 22.35m. Kuşāṇa. L.19

107. Crowned head of a male with moustache. Hand-modelled, solid. Broad face with overemphasized features. Strong eyebrows decorated with incised strokes. Deep-set eyeballs framed by convex eyelids. Large circular iris. Moustache decorated like the eyebrows. Mouth deepened and slightly open. Traces of a semicircular incision starting on one side of the mouth, indicating a double-chin as in nos. 105–106. Left ear preserved as a small projection standing out sideways, showing a pierced hole as with the ears in nos. 100, 105, 106. The man wears a tripartite crown above the extremely low forehead. This crown is shaped like a three-stepped wall-crest in its centre. Back smoothly rounded.

H. 10.7cm. Colour: red. No. So I 250.

FS. 3 I 0.5/Cb 15.2, H. 21.25m. Filling. Kuşāṇa.

108. Head of a crowned male with moustache. Hand-modelled, solid. Eyebrows edged by incised line, below it traces of vertical

decorative strokes. Eyelids incised, eyeballs pricked. Curved moustache above slightly open mouth. Large ears drawn sideways. Above the low forehead a lofty crown consisting of three sectionally punctured bands, giving the impression of a metal diadem, topped by a central head-piece. At the back vertical strokes indicating combed hair.

H. 13.5cm. Colour: brown-red. No. So I 182.

FS. 2 III 4.3/Cc 7.4, H. 22.30m. Kuşāṇa. L.18

109. Pyramidal object with male head. Hand-made. A hollow conical stand with unproportionally large head. The stand itself is decorated as if forming the bust of the figure. Large incised eyes with pierced eyeballs under elevated eyebrows shortening the forehead to nil. Nose partly broken off. The upper lip above thick-lipped and slightly open mouth is denoted by an incised vertical stroke. The moustache extends in two wavy lines to the ears. A greater number of dots marks a goatee all around the chin. A semicircular incision leading from the sides of the lips downwards is possibly marking a double-chin. Above the nearly vanished forehead a ring of vertically lined upturned hair (or diadem) is visible, topped by a now broken off object (turban-cloth?).

H. 16.6cm. Ø 7.9cm. Brown, red slip, blackened by fire.

No. So I 171. FS. 2 IV 6.0/Ca 8.5, H. 22.65m. Kuşāṇa. L.19

110. Small human head. Weatherworn face. Hair cloth-covered with low central bulge. Ear-ring in left ear.

H. 3.2cm. Colour: yellow-brown. No. So I 200.

FS. 2 IV 14.25/Cb 11.85, H. 21.90m. Kuşāṇa. L.20

111. Head of a soldier with helmet? Hand-modelled. Eyebrows and eyelids incised. The weatherworn condition of the piece does not permit to recognize the details of the face and head-dress. The upper part looks like a helmet with vertical incised lines. The projection in front and the transition from the lower part of the head-dress to the helmet remains indistinct.

H. 7.4cm. Colour: light brown. No. So III A 1154.

FS. 2 IV 5.2/Ca 18.3, H. 22.80m. Kuşāṇa. L.18

112. Human head. Hand-modelled. Plump cheeks lifted up. Extremely broad incised eyes with large semicircular pupil. Wide mouth. Nose and forehead broken off. Root of nose and eyebrows in angular connexion. Auricle of naturally shaped left ear showing incised lines; ear-disc with concentric circles. Remains of a ribbon, chipped off above forehead, visible on back of the head.

H. 7.5cm. Red-brown, green and darkbrown spots.

No. So I 186. FS. 2 V 6.2/Cb 16.4, H. 21.50m.

Kuşāṇa. L.19

113. Mutilated human head. Hand-modelled, solid. Broad face with plump cheeks and large open eyes. Eyelids incised, eyeballs pricked. Thick lips with a vertical groove in the centre. Auricle of remaining left ear showing incised lines; ear-discs adorned with concentric circles. Of the head-dress traces only are left, indicating a diadem-ring or multiple garland with frontal ornament. This ring extends from ear to ear, the remaining part of the head being completely undecorated. The back is clumsily rounded.

H. 9.5cm. Brown, blackened by fire. No. So I 233.

FS. 2 IV 5.3/Ca 9.85, H. 22.85m. Kuşāṇa. L.18

114. Face of a hollow human figure. Perforation from ear to ear. Filled with sand. Plump cheeks, large open eyes. Eyelids incised. Eyeballs scratched, nose widely broken off. Mouth unusually small and flat. One ear-disc only is preserved. Ring of diadem with central jewel above extremely low forehead. Back smoothly rounded.

H. 9.5 cm. Red-brown, blackened by fire. No. So I 161.
FS. 2 IV 14.85/Cb 12.1, H. 22.80 m. Late Kuṣāṇa. L.17

115. Head of human figure. Hand-modelled, solid. Plump cheeks, incised eyebrows and eyelids. Iris underlined by semi-circles, pupils punctured. Uprturned nose above pouted lips. Ears shaped like those in nos. 112–113 with incised lines in auricles and adorned with concentrically grooved ear-discs. Broad neck with three incised horizontal folds. Above the low forehead a sliced band, now chipped off, seems to have been applied, a small piece of which is retained on the smoothly rounded back of the head.

H. 10.3 cm. Colour: brown. No. So I 385.
FS. 2 IV 12.7/Be 8.5, H. 23.60 m. Late Kuṣāṇa. L.16

Goddesses and Gods

116. Encrusted right upper corner of a plaque depicting the six-armed Durgā Mahiṣāsuramardīnī (DMM) in the act of killing the buffalo-demon. Defaced head slightly inclined towards the upturned muzzle of the buffalo's head behind which the back left arm is raised in order to hold the garland above her head. The middle left arm is bent upwards, its hand holding a shield. The lower left hand, formerly grasping at the neck of the Mahiṣa, is broken off.

H. 9.0 cm. Colour: reddish with mica. No. So III A 1662.
FS. 2 V 1.2/Ca 19.1, H. 21.10 m. Kuṣāṇa. L.21

a) Fragment of six-armed DMM-plaque. Weatherworn head of the goddess and right middle hand holding the garland on the head of Durgā. Eyeballs pierced.

H. 6.8 cm. Colour: red-brown. No. So III A 1690.
FS. 2 IV 6.9/Cb 12.8, H. 21.55 m. Kuṣāṇa. L.21.
Found immediately south of Apsidal Temple no. 1.

117. Fragment of weatherworn plaque of the six-armed Durgā killing the buffalo-demon. Bust of the goddess turned towards the uplifted head of the animal. The raised back hands hold the garland above the head of Durgā. In the middle right hand the shaft of presumably a dagger is visible, the middle left hand holds a shield. The lower right arm is turned down, its hand originally placed on the spine of the buffalo. Of the lower left hand, strangling the neck of Mahiṣa, no traces are to be seen. Face and bust of the goddess are too much worn to recognize details.

H. 12.6 cm. Colour: grey-brown. No. So III A 1664.
FS. 2 IV 8.0/Cb 15.5, H. 21.85 m. Kuṣāṇa. L.20/19
Found immediately south of Apsidal Temple no. 1.

118. Upper part of mould of a plaque showing six-armed Durgā killing the buffalo-demon Mahiṣa. Eyes and eyebrows depicted in the typical Kuṣāṇa mode of stone sculptures. In the left ear she wears a small, in the right a suspended ear-ring. A plain necklace winds between the breasts, the nipples of which are shaped as a circle with central point. The hair is arranged in horizontal strands towards the sides and overlapped by a vertically stringed hair-bulge in the centre. As far as visible, all the arms are adorned with four armllets and bracelets each. The back arms support a garland above the head of Durgā. The hands of the bent middle arms hold a dagger and an upturned three-pronged triśūla respectively. While the hand of the right front arm is pressed on to the (broken off) back of Mahiṣa, the lower left hand is squeezing his neck. The muzzle of the buffalo stands slightly open with the tongue protruding. The large right eye and the parting horns of the animal are visible along the left side of the goddess.

H. 13.0 cm. Colour: grey. No. So I 221.
FS. 2 V 19.2/Cb 17.6, H. 21.20 m. Kuṣāṇa. L.20/19

119. Upper part of a plaque with the bust of the six-armed Durgā. Whole part with the buffalo and the left arms of the goddess chipped off. Facial features and head-dress same as described in no. 118. As the eyes are slipped, the originally pricked eyeballs look blind now. The ear-rings do not seem to differ. The nipples of the breasts are indicated by pricked holes. The preserved right arms show an arbitrary number of incisions indicating armllets and bracelets. The back hand supports an ornamented garland, the middle hand holds a dagger with blade upwards, and the front arm is lowered towards the broken off back of the buffalo.

H. 14.0 cm. Brown, red slip with mica. No. So I 191.
FS. 2 IV 13.3/Ca 15.25, H. 22.30 m. Kuṣāṇa. L.19

120. Upper half of a plaque depicting six-armed Durgā killing the buffalo-demon. Face retouched. Large eyes, eyeballs pierced. A hole in the centre of forehead. Smaller ear-ring in the left, a larger one in the right ear. Necklace depicted as consisting of beads. Breasts pricked. As far as visible, all the arms adorned with an inconsistent number of incised armllets and bracelets. Back hands support a garland above the Durgā's head, middle hands hold a dagger (proper right) and a shield respectively. Right front arm lowered to the spine of the Mahiṣa, hand of the left arm grabs the neck of the buffalo whose muzzle stands open with the tongue protruding between the lips. Two holes in the muzzle denote the nostrils, the animal's left eye is given as a longish slit. The structure of the horns is marked by horizontal strokes. Back of the plaque plane.

H. 13.2 cm. Red-brown, dark brown slip. No. So I 166.
FS. 2 IV 8.0/Ca 3.8, H. 23.20 m. Kuṣāṇa. L.17

a) Fragment of a DMM-plaque. Weatherworn bust of the goddess with upturned head of the buffalo and the three left arms in the usual position: back hand supporting garland, middle hand holding a shield, lower hand grabbing the neck of the animal. Back flat.

H. 11.0 cm. Colour: red-brown. No. So III A 1663.
FS. 2 III 5.5/Cc 4.0, H. 22.60 m. Kuṣāṇa. L.18/17

121. Fragment of a plaque showing the six-armed goddess Durgā from breast to knees pressing her lower right hand on to the spine of the buffalo. The corresponding left hand is missing but the upper left hands hold garland and dagger. The buffalo is standing on his hind legs with head uplifted in front of the goddess and body stretched across her thighs, his tongue protruding. The horns and one ear is clearly visible. At the right side of the plaque part of the edge is bent to front showing concave roundish marks. Back flat.

H. 14.3 cm. Colour: red-brown. No. So III A 1072.
FS. 2 IV 17.1/Cb 19.7, H. 22.50 m. Kuṣāṇa. L.17
Found within Apsidal Temple 1.

a) Lower part of a DMM-plaque. Hind-legs of the buffalo and anklet-adorned feet of the goddess.

H. 8.9 cm. Colour: brown. No. So III A 1040.
FS. 2 III 7.5/Cc 5.3, H. 22.91 m. Kuṣāṇa. L.17

b) Small fragment of DMM-plaque. Left back hand supporting garland and left middle hand holding dagger(!).

H. 6.3 cm. Colour: brown. No. So III A 564.
FS. 2 IV 16.4/Cb 19.45, H. 24.05 m. Late Kuṣāṇa.
L.16/15. In area of Apsidal Temple 1.

122. Fragment of upper left corner of a DMM-plaque. Defaced head of the originally six-armed goddess with slantwise striped garland supported by the right back hand. Traces of the right middle hand holding dagger. Back flat.

H. 8.5 cm. Colour: red-brown. No. So III A 968.
FS. 2 IV 16.7/Cb 8.85, H. 23.05 m. Late Kuṣāṇa.
L.17/16. In area of Apical Temple 1.

123. Unstratified upper part of a plaque showing the four-armed goddess Durgā in the act of killing the buffalo-demon Mahiṣa. The oval face of the goddess is heavily eroded. Her hair is incised as if combed in vertical strands arranged in two steps one above the other. At the neck she wears a tight-fitting collar punched with circlets. The nipples of her full breasts are denoted by pricked holes, a triangular navel is conspicuously cut into the stomach of the slim-waisted figure. The right front arm is lowered to the broken off back of the buffalo whose upturned muzzle is just preserved on the front left arm. Both the back arms are bent, the raised hands holding a short-shafted trident-like object with prongs pointing downwards and an indistinct attribute marked by four horizontal lines, presumably a shield. Back unmodelled. In an article titled *Early Durgā Mahiṣāsuramardinī Images – A Fresh Appraisal*, delivered for a felicitation volume for Klaus Fischer already in 1987, the author discusses the probability that the object in the right hand might be a vajra rather than a triśūla. P.S. Just released, see Härtel 1992.

H. 8.8 cm. Colour: grey with red slip. No. So I 226.
FS. Surface find, therefore out of context. On the analogy of style and iconography the piece can safely be assigned to the later Kuṣāṇa period.

124. Plaque showing the four-armed Durgā in the act of killing the buffalo-demon. Composed of two pieces found in different spots of the excavation area but fitting together perfectly. Durgā is ready to attack the buffalo standing on his hindlegs with head uplifted in front of the goddess and body stretched across her legs. Her right front arm is lowered to the back of the animal with the hand pressing on its spine while the left lower hand grabs its neck. The upper two arms are raised in an unusual position holding a trident-like object with both the hands above the head, ready to strike down into the body of Mahiṣa.

This plaque is a rather popular product and no doubt of poor artistic quality, but its iconographical features give it an unexpected importance, the more so as the piece is safely datable. As to the object in the upper hands the author refers to the remarks in no. 123 and to the article mentioned therein, in which a fragment of a huge stone sculpture of a DMM of late Kuṣāṇa Mathura style is published showing clearly a vajra in the upper two hands in front of the forehead of the goddess.

H. 18.3 cm. Colour: red-brown. No. So I 143.
FS. 2 IV 1.9/Ca 6.45, H. 23.45 m.
2 IV 8.75/Cb 8.1, H. 24.10 m. Late Kuṣāṇa. L.16

125. Upper part of a popularly styled plaque with the bust of goddess Durgā combatting the buffalo-demon Mahiṣa. The goddess is four-armed, her face looks strange because of the broadly applied pierced eyes. The low forehead is crowned with a horizontally striped head-dress with central ornament. The neck is adorned with a tight-fitting collar decorated with incised strokes. The bulgy front arms are lowered to the broken off back of the buffalo (right arm) and to the neck of the animal whose muzzle is turned up. The right back arm is bent up and holds a short-shafted trident with its three prongs pointing upwards. The impression of a longer stick along the edge of the plaque is wrong. Unfortunately, the object in the left back arm can not be identified with certainty.

H. 8.8 cm. Brown, blackened by fire. No. So I 137.
FS. 2 IV 2.5/Ca 12.25, H. 23.70 m. Late Kuṣāṇa. L.16

126. Unstratified fragment of popular type of the goddess Durgā, probably depicting her as fighting the buffalo-demon. Of the four-armed deity the head and the right back arm only are preserved. The head is surrounded by a sort of niche or baldachin as known from many female stone figures of the Kuṣāṇa period. The face is awfully plastered with patches for the eyes, eyebrows and mouth. A large round ring hangs in the right ear. Her matted hair is arranged in two steps. The right front arm shows by its fracture that it was stretched downwards. In the hand of the raised right back arm the goddess holds a short-shafted trident with prongs turned upwards. Back unmodelled.

H. 6.9 cm. Colour: brown, red slip, crusted. No. So I 314.
FS. Surface find. Because of the short-living mode of depicting Durgā holding a short-shafted trident with prongs upwards this popular plaque can safely be dated to the Kuṣāṇa period.

127. Upper part of a plaque showing four-armed goddess Durgā. Face worn, back hands and attributes mutilated. Hair combed in vertical strands arranged in two layers one above the other. The figure is embellished with ear-rings, bracelets and a long necklace reaching down between the breasts to the side of the navel. Over the left shoulder hangs a folded shawl. Three of the arms are bent upwards, the lower right hand holding a wavy dagger or a short-shafted trident, the upper right a shield and the upper left an indistinct object with a longish shaft of stalk decorated like a garland. The left front arm is lowered, its hand seems to touch something or someone stretched horizontally across the body of the goddess, reminding one of the position of the buffalo in the DMM-plaques. Here it would make sense only if we accept the goddess as holding the animal by the tail (see horizontal stripes), but such an interpretation would not fit with the situation of attributes and number of arms. Strongly chaff-tempered.

H. 11.5 cm. Brown, blackened by fire. No. So I 214.
FS. 2 V 11.8/Cb 11.2, H. 21.60 m. Kuṣāṇa. L.20/19

128. Upper part of a plaque depicting two-armed female. Breasts and right arm mutilated. Lenticularly shaped eyelids with convex pupils under horizontal eyebrows. Circlet of diadem over cloth-covered hair. Large pendant in left ear. Pleated garment arranged on left shoulder over left upper arm. Breasts seem to protrude from under the garment. The hand of the raised right arm presumably holds a sword. Unusually sharp-edged plaque.

H. 10.2 cm. Dark brown, core carbonized. No. So I 156.
FS. 2 IV 9.6/Ca 14.45, H. 23.65 m. Late Kuṣāṇa. L.16

129. Plaque with two-armed standing goddess. Face and attributes chipped off. Circlet around upturned hair-strands. Vertically striped collar. Shawl over left shoulder, lower garment kept by a girdle. Full breasts with nipples denoted by holes. Right arm bent upwards, hand holding a sword presumably. Left arm akimbo. Above it a defaced lenticular object, perhaps a shield in profile. Back unmodelled. Strongly chaff-tempered.

H. 20.0 cm. Colour: light brown. No. So I 163.
FS. 2 V 10.25/Ca 15.8, H. 22.97 m. Late Kuṣāṇa. L.17/16

130. Fragment showing parting upper arms of four-armed figure with incisions of armllets.

H. 7.3 cm. Colour: grey-brown. No. So III A 2660.
FS. 2 III 10.5/Cb 16.5, H. 21.80 m. Kuṣāṇa. L.20/19

131. Mutilated torso of a four-armed goddess. Of the arms, the fractured surface only of the point of projection is visible. Garland hanging from right shoulder. Vertically grooved girdle applied loosely from hip to hip. Three-stringed cloth wound around waist. No other marks of identification. Unfortunately, this piece could not be described on the basis of the original.

1 H. 7.3 cm. Colour: brown. No. So III A 1350.
FS. 2 III 6.7/Cc 3.8, H. 22.70 m. Kuṣāṇa. L.18/17

132. Fragment of a plaque showing seated Mother Goddess with child in her lap. Head, left arm and greater part of legs broken off. Necklace of beads winds between breasts. Right arm bent, hand pressing left breast. Armlet and bracelet incised. Clumsily shaped child being held with left hand. Eyes and mouth of child indicated by simple strokes. Back unmodelled. Strongly chaff-tempered.

H. 10.0 cm. Colour: red-brown. No. So III A 1049.
FS. 2 IV 12.2/Cb 19.0, H. 22.42 m. Late Kuṣāṇa. L.17
Found at the entrance side of Apsidal Temple no. 1.

133. Fragment of a plaque showing seated Mother Goddess with child in lap. Resembling no. 132 but made from different mould. Head and left arm broken off. Right arm bent, its hand touching left breast. Armlet and bracelet incised. Bent legs set apart. Child lies in the lap, supported by the left hand of the mother. Face of child rendered better than in no. 132. Fingers of left hand marked by incisions. Back flat. Strongly chaff-tempered.

H. 9.2 cm. Colour: red-brown. No. So III A 1023.
FS 2 IV 13.0/Cb 10.0, H. 23.05 m. Late Kuṣāṇa. L.17/18.
Found within Apsidal Temple no. 1.

134. Two fitting fragments of a seated female figure. Hand-modelled. Head, arms and left leg broken off. Of the decorations, the lower part of a necklace with oblong pendant is preserved. Folds of the garment are visible on the left shoulder, in the lap and on the outside of the bent right leg. Above the damaged feet an anklet is applied. At the back in height of the breast a horizontal three-stringed elevation is shown, marking skin folds presumably. Strongly chaff-tempered.

H. 17.5 cm. Colour: brown. No. So III A 891.
FS 2 IV 8.58/Ca 7.7, H. 23.35 m.

2 IV 9.5/Ca 2.9, H. 23.62–27 m. Late Kuṣāṇa. L.16

135. Bust of a pot-bellied male figure. Hand-modelled, solid. Forehead and head-dress broken off. Deeply incised slanting eyelids, eyeballs pierced. Nose chipped off. Three-stringed horizontally combed moustache. Semicircular incision below the mouth indicates a double chin. Broad-winged ears with two holes each, one above the other. Large and richly ornamented ear-rings. A split at the neck shows the junction point of head and body. The head being lifted, the tenon becomes visible. Extending from shoulder to shoulder two necklaces are seen lying on the fat belly so prominent by its large navel pit. The upper necklace consists of a ribbon decorated with punched circles, the lower one is depicted as a precious chain composed of horizontal strings separated by vertical links punched with circlets. An indistinct piece of punched ribbon and two plane discs are resting on the left shoulder. Both the arms are bent, the right hand holding an oblong object, the left a mutilated bowl. The figure was, in all probability, seated. The back is flat.

Judging by the pot-belly and the objects in the hand one is inclined to identify the figure as Kubera. If so, the oblong piece in the right hand may be taken as the mongoose purse of this god. It is highly probable that all the larger seated male figures described here under nos. 135–140 represent the same god. It just remains to be noted that in case of no. 139 the purse (or flask?) is held in the left hand.

H. 17.5 cm. Colour: brown, red slip. No. So I 272.
FS. 2 V 10.45/Cb 12.3, H. 21.25 m. Kuṣāṇa. L.20

136. Body of a seated male figure. Hand-made, hollow, core of legs carbonized. Head, left arm and leg broken off. Figure is pot-bellied showing a big navel pit. Between belly and breast a con-

cave two-stringed band is wound around the chest. The right arm is adorned with two rings and rests on the right thigh. The hand is damaged but obviously held an object. Below the hand the folds of the garment are visible on the knee. Some more folds are broadly arranged between the legs. A vertically incised necklace surrounds the neck. Of the seat, only a small part is retained under the right thigh. Surface and inside of the figure show the typical rough Kuṣāṇa chaff-temper.

H. 21.8 cm. Colour: red-brown. No. So I 183.
FS. 2 IV 6.6/Ca 8.7, H. 21.75 m. Kuṣāṇa. L.21

137. Fragment of a seated male figure joined together by pieces found in two different spots of the excavation area. Hand-made, hollow. Left side only with shoulder, breast, arm and part of bent leg preserved. Remains of an ear-ring and a necklace, both adorned with incised strokes. Slightly elevated nipple marked by an impressed circle. Left arm rests on thigh, hand holds a bowl. Strongly chaff-tempered.

H. 26.3 cm. Colour: red-brown. No. So III A 952.
FS. 2 V 3.65/Ca 13.9, H. 21.80 m.
2 V 3.60/Ca 14.5, H. 21.75 m. Kuṣāṇa. L.20

138. Torso of seated male figure. Hand-made, solid. Huge pot-belly with large navel pit. Arms and legs broken off, so that the stem of the seat, identical with the extended back, stands in the open. Strongly chaff-tempered.

H. 15.8 cm. Colour: grey-brown. No. So III A 2233.
FS. 2 V 14.9/Cb 19.2, H. 20.85 m. Kuṣāṇa. L.21

a) Torso of seated male figure as no. 138. Huge belly, large navel pit, indication of nipples.

H. 6.8 cm. Colour: red. No. So III A 1832.
FS. 2 IV 8.6/Ca 16.7, H. 21.80 m. Kuṣāṇa. L.21

b) Mutilated torso of seated male figure. Hand-made, solid. Details worn.

H. 13.0 cm. Colour: red-brown. No. So III A 1412.
FS. 2 V 0.5/Ca 14.2, H. 21.20 m. Kuṣāṇa. L.21

139. Seated headless male figure. Hand-modelled, solid. Traces of ear-rings resting on the shoulders. Horizontally arranged necklace extending from shoulder to shoulder, decorated by vertically incised strokes. Small nipples above a horizontal fold of skin visible over the remarkable pot-belly prominent by its large navel pit. The arms, adorned with two bracelets each, are bent and lying on the knees. The right hand keeps a bowl, the left one an indistinct object, presumably a mongoose purse or flask (see no. 135). The seat is compact and U-shaped. Back unmodelled.

H. 19.2 cm. Brown, red slip, white spots. No. So I 238.
FS. 3 I 4.0/Cb 4.0, H. 19.45 m (pit). Kuṣāṇa. L.19

140. Rump of a seated male figure. Hand-modelled, solid, carbonized core. Head, arms and the whole leg-part broken off, laying bare the fractured seat. Quite similar to no. 139. Necklace and nipples above double-fold of skin over pot-belly.

H. 25.8 cm. Colour: red-brown. No. So I 121.
FS. 2 IV 10.75/Ca 2.7, H. 22.60 m. Kuṣāṇa. L.19/18

141. Fragment of an ogre. Moulded plaque. Head and shoulders of a frightful looking demon with wrinkled face, broad nose, goggle eyes and wide open mouth. His head-dress consists of two layers of hair and a sort of garland upon it. To the sides of his neck and head two arms are raised of a human figure pressed against the demon's body, leaving the naked back exposed. The head of the human figure seems to vanish in the mouth of the ogre.

H. 6.0 cm. Colour: grey-brown, red slip. No. So I 289.
FS. 2 III 14.3/Cb 17.35, H. 21.95 m. Kuṣāṇa. L.20

142. Mould of fraction of a medallion depicting half of a seated Nāgarāja. Left side of cobra-hood, face and body of the Nāga. The face shows the features of the Kuṣāṇa stone figures of Nāgas with sharply carved eyes and protruding eyebrows. The hair is vertically striped giving the impression of being upturned. Of the hood three cobras are left rising to the side and behind the head. The Nāga is adorned with ear-ring, necklace, armband and bracelet. The left arm is akimbo with the hand not touching the hip but holding an indistinct object. The left leg, set wide apart, is placed in front of a coil of the serpent, reminding of the coils projecting behind stone images of standing Nāgas. The background of the medallion is decorated with lotus leaves arranged as a rosette edged by a plain border.

Considering the size and design this mould had obviously been modelled from a sūcī or stambha of a stone railing.

H. 18.0 cm. Colour: grey. No. So I 286.

FS. 2 V 5.65/Cb 15.15, H. 20.75–19.75 m.

Kuṣāṇa. L.(22)/21

143. Fragment of a mould similar to no. 142. Part of half a medallion with proper left side of cobra-hood, face and shoulder of a Nāga. In the background the petals of a lotus rosette.

H. 15.5 cm. Colour: grey. No. So I 287.

FS. Exactly same as no. 142.

144. Fragment of a larger plaque showing a standing male from shoulders down to knees. Right knee slightly bent. The man is wearing a dhotī with a shawl winding from the left shoulder over the left arm towards the right knee while the lower part of the garment is fastened by a girdle. The right arm is raised, its hand held in the mudrā usually named as *abhaya*, but with the palm turned inwards (*vyāvṛtta* position), indicating a royal gesture. The left hand holds a flask. Although the background of the plaque is in bad condition, traces of two incised small circles can be made out on the right side. They permit us to conclude that serpent-coils were depicted at the sides of the man, identifying him as a Nāga.

H. 13.8 cm. Colour: red-brown. No. So I 146.

FS. 2 IV 10.7/Ca 16.8, H. 23.40 m. Late Kuṣāṇa. L.17/16.

On account of its style the plaque might have originated from an earlier Kuṣāṇa level.

a) Unstratified standing male with damaged head. Heavy ear-rings. Right arm raised, hand turned inwards. Left hand rests on thigh. Long garment, bulky scarf around hips. Back flat.

H. 12.0 cm. Colour: brown. No. So III A 532.

FS. Surface find. Out of context.

Stylistically clearly Kuṣāṇa.

Miscellaneous Objects and Figures

145. Fragment of a handle showing front and back of a couple under a tree. Made from two moulds. The woman stands to left, the man to right. Both the faces are well-worn, the man's partly scraped off. The woman's hair is artfully laid in loops on the forehead, most of them taken backwards in a large lateral bulge ending on the back in an unusual strong and long plait. She is adorned with ear-rings and a plain necklace falling over the breasts. Her raised right hand holds a flower on the shoulder. She is leaning against the tree, putting her left arm around the trunk with the hand appearing between the branches in front. The man, embellished with a peculiar stringed necklace, holds the right hand to his chest. His hair seems to be arranged in curls. With the exception of the plain ribbon of the necklace the back is undecorated. The tree is full of leaves and fruits on both sides. As there is no other object hanging in the branches it does not look like a *kal-*

pa-vrkeṣa. On the edges the joint of the two sides of the plaque is to be seen as a broad band. The fabric is rather fine.

H. 6.8 cm. Colour: red-brown. No. So I 336.

FS. 2 III 8.8/Cc 8.2, H. 21.00 m. Kuṣāṇa. L.21

146. Mutilated hollow round plaque. Moulded thin-walled and provided with a perforated triangular lug, so that the piece could be worn on a string or chain. On the rim beside this lug there is a small hole through which globules or pebbles were inserted for the object to serve as a rattle. The obverse side shows a group of figures, superbly shaped, depicting an ensemble of bodies consisting of one lower and four upper parts joined in an intriguing manner. Each figure performs a different movement. Thus, the whistling man near the lug seems to be sitting, while the clapping figure on the left appears to float. The other two figures are given in dancing or singing postures. The representation of whistling, clapping, singing and dancing people on the plaque is certainly in harmony with its function as a rattle. The reverse side shows the remains of a lotus decoration (see no. 147).

Ø 10.5 cm. Depth 3.5 cm. Grey, red slip. No. So I 194.

FS. 3 I 4.3/Ca 13.9, H. 21.40 m. Kuṣāṇa. L.21

147. Fragmentary hollow round plaque. Moulded as no. 146. Lug and hole for filling lost. The obverse side shows a headless but beautifully shaped couple with the male to left. His raised right hand is held towards his chest, the left arm embraces the woman. One spiral ear-ring and one solid bangle are the only remains of adornment. He wears a lower garment indicated by folds and a bulky scarf around his hips. The woman wears spiral ear-rings, an ensemble of bangles on the lowered arm, anklets, and a girdle fastening the short garment of thin fabric. Her right arm vanishes behind the back of the man. The scene extends to the garland border framing the rattle. The reverse side of the plaque is decorated with a full-blown lotus in the centre and floral patterns in concentric bands.

Ø 10.5 cm. Depth 3.3 cm. Grey, red slip. No. So I 193.

FS. Found side by side with no. 146. Kuṣāṇa. L.21

148. Solid round plaque showing on the obverse a study of a ferocious lion standing over its prey. The lion stretches across the whole width of the plaque with the head turned backwards and mouth open. On the shoulder the mane is incised in vertical lines. The tail seems to be in brisk movement. Under the legs two wild boars and, on the lower edge, an iguana is depicted. On the reverse is shown a floral design consisting of twelve flowers sharing their four petals. The narrow edge is decorated with a finely carved creeper all around.

Ø 9.0 cm. Depth 2.0 cm. Brick-red. No. So I 301.

FS. 2 IV 19.7/Ca 9.5, H. 22.24 m. Kuṣāṇa. L.19

149. Lower part of a plaque with the legs of a couple. Man to left, woman to right. He wears short garment with fillet in front. His left knee is bent, the leg set slightly sideways. She is clad in a pleated lower garment kept by a girdle and standing with the left leg crossing her right leg. Her left arm is lowered, the hand touching the left thigh. An anklet is applied to the right foot only.

H. 7.3 cm. Colour: brown-red. No. So I 230.

FS. 3 I 4.4/Cb 2.7, H. 20.65 m. Kuṣāṇa. L.21(1).

a) Worn fragment of a plaque with legs of couple. Man and woman in same position as in no. 149. Details corroded.

H. 7.4 cm. Colour: red-brown. No. So III A 1225.

FS. 2 IV 9.5/Cc 8.3, H. 21.20 m. Kuṣāṇa. L.21

150. Fragment of the back of a seated couple. Made from two moulds. Heads, legs and whole front missing. Back of man to

right, woman to left. She seems to sit on the left thigh of the man. His left arm lies on her back covered partly with long plaits of her hair. She wears a three or four-stringed girdle, his lower garment is kept by a double ribbon wound around the hips.

H. 5.0 cm. Colour: brown. No. So III A 677.

FS. 3 I 1.3/Cb 4.95, H. 22.85 m. Kuṣāṇa. L.18/17

Perhaps a relict of an earlier level.

151. Fragment of a seated headless drummer beating a drum with both hands. Broad collar decorated with vertical grooves. Left leg broken off. Horizontal break in the back indicates the figure having been part of an ensemble sitting against a wall.

H. 8.6 cm. Red-brown, encrusted. No. So I 11.

FS. Trench 1, C13, H. 23.30 m. Kuṣāṇa. L.17

152. Foot upon six-pronged object. No toes visible. Two rings adorn the ankle. The prongs show rounded tips, they are not continuing to the sides. The upper and lower tines to left display two sharp folds on their inside. In the centre a semicircular patch is visible. The lower edge of the piece is broken off and the back as rough as if split away. This fragment is perhaps part of a terracotta relief.

H. 6.5 cm. Colour: red-brown. No. So I 299.

FS 2 IV 7.5/Cb 9.65, H. 22.05 m. Kuṣāṇa. L.18

153. Bust of a male figure. Type of rider. Face moulded. Turban with bulge to right. Long-drawn ears with ear-rings. Narrow face. Deep-set eyes with thick eyelids and protruding eyeballs under pronounced brows. Circular collar decorated with punched holes. Right arm broken off, left upper arm bent forward. Back smoothly rounded. Traces of a hair-strand on flattened back of head.

H. 8.0 cm. Red, strong mica slip. No. So I 167.

FS. 3 I 7.0/Ca 18.3, H. 20.95 m. Kuṣāṇa. L.21(1)

154. Seated man with (broken off) legs apart. Decorative object. Hand-modelled. Right hand on breast, stump of left arm stretched sideways. Body broad-hipped, ending in a sherd of a pipe or vessel. Back of the figure unfinished, obviously joined to some device previously. Head flat, face triangular. Thick lips. Eyes applied as broad patches, pupils indicated as pierced holes. Sharp-cut eyebrows under low forehead. Head-dress broken off. Broad ears marked by a perforation. Coarse fabric, chaff-tempered.

H. 17.7 cm. Grey-brown, red slip. So I 204.

FS. 2 IV 7.4/Ca 11.95, H. 22.20 m. Kuṣāṇa. L.19

155. Unstratified fragment of a plaque. Lower part of a scene. At the bottom a 2.6 cm high comb border. On the left traces of a floral edge. In the centre a female figure kneeling on her left knee. Body broken off above hips. She wears a five-stringed girdle with an ornamental buckle in the centre. On the feet traces of anklets. To the right and left worn legs of accompanying figures.

The position of the woman reminds one strongly of the famous so-called Bacchanalian relief from Mathura (National Museum New Delhi).

H. 5.3 cm, B. 7.7 cm. Colour: brown. No. So I 4.

FS. Stray find. Out of context, but certainly Kuṣāṇa.

Boyish Figures

There is a small group of terracotta figures of a type which V. S. Agrawala (1984, fig. 39, p. 32) describes as "Terracotta Yakṣa showing a corpulent boyish figure with a bell round the neck, the hands pressed against the breast and conspicuous genitals". While Agrawala dates this type as Śuṅga, all the specimens from Sonkh

have been found in Kuṣāṇa levels exclusively. As it is doubtful whether these figures, in spite of their pot-belly, can be taken as Yakṣas, they are registered here as BOYISH FIGURES. This type should not get mixed up with that of the Nude Dwarfs to be found frequently and over a longer time between the Mitra and late Kuṣāṇa periods, discussed below in Appendix I.

156. Headless boyish figure. Made from two moulds. Slightly pot-bellied. Clenched fists pressed against the breast. Traces of a necklace with a bell hanging in front. The boy wears bracelets, girdle of globules and anklets. He is bow-legged with a plain space of clay in between on which the genitals are conspicuously displayed.

H. 5.9 cm. Colour: red. No. So III A 1682.

FS. 2 V 14.0/Ca 17.4, H. 21.18 m. Kuṣāṇa. L.21

157. Boyish figure with clenched fists on breast. Made from two moulds. Big longish head. Thick eyelids and protruding eyeballs. Loosely combed strands of hair divided in the middle but without parting. Only traces of the ears. Necklace with bell round the neck. Armlets and bracelets. Pot-belly with navel. Girdle consisting of globules. Prominent genitals. Legs broken off.

H. 6.8 cm. Colour: red. No. So III A 1921.

FS. 3 I 4.5/Cb 5.0, H. 21.18 m. Kuṣāṇa. L.21

158. Headless boyish figure with clenched fists raised to the breast. Moulded. Frontal string of necklace with a bell as pendant. Pot-belly with fleshy fold above. Navel. Armlets, bracelets, anklets. Girdle of boxes. Figure bow-legged with plain space of clay in between. Genitals less noticeable than in nos. 157–157.

H. 7.3 cm. Colour: red. No. So III A 2165.

FS. 2 V 4.8/Cb 1.2, H. 21.25 m. Kuṣāṇa. L.21(2)

159. Fragment of headless boyish figure. Made from two moulds. Clenched fists raised to the sides of the breast. Frontal part of necklace with bell pendant. Grooved fold above pot-belly. Navel. Worn girdle of globules. Right thigh and rest of the legs broken off. Traces of the genitals.

H. 6.9 cm. Colour: red. No. So III A 1683.

FS. 2 III 7.8/Cc 4.3, H. 22.35 m. Kuṣāṇa. L.18

160. Head of boyish figure. Moulded, back flat. Hair-do and facial features as in no. 157 but with circular pupils. Spiral-shaped ear-ring in right ear.

H. 3.2 cm. Colour: light brown, traces of red colouring.

No. So I 169. FS.2 IV 3.3/Cb 4.0, H. 23.15 m. Kuṣāṇa. L.17.

Presumably originating from L.21.

a) Head of boyish figure. Hair-do similar to nos. 157 and 160. Low forehead. Ear-drops.

H. 3.5 cm. Colour: brown. No. So I 154.

FS. 2 IV 4.97/Ca 10.33, H. 23.89 m. Late Kuṣāṇa. L.16

161. Worn fragment of headless boyish figure. Moulded. Arms bent upwards, hands broken off. Pot-belly with round navel pit. Girdle as in no. 158. Bow-legged with plain space of clay in between. Remains of genitals. Back flat.

H. 6.5 cm. Colour: brown. No. So III A 697.

FS. 2 IV 10.0/Ca 7.45, H. 24.40 m. Late Kuṣāṇa. L.15

Fragments of Human Bodies

The excavation yielded a large number of arms and legs broken off from mostly larger hand-modelled figures produced from the end of the Kṣatrapa to the end of the Kuṣāṇa periods. It is useful

to take note of the main shapes of these extremities. A few remarkable details require attention.

1. The *arms* from Levels 23–22/21 are either stiffly made or strongly curved and often tapering towards the hand. They are adorned with one or more undecorated bulgy bangles. The fingers are, with the exception of the two earliest pieces, dismembered or not marked at all.

2. The *legs* from Levels 23–22/21, shown as a rule as seated, follow the shape of the arms, i.e. they are tapering from thigh to ankle. The thighs are extremely thick, the feet often dismembered, the toes indicated by grooved strokes.

3. The *arms* found in Levels 21 to 18 hail obviously all from large Kubera figures, showing incised decorations and a bowl or purse in the hand. The fingers are either given in natural shape or indicated by incisions.

4. The *legs* found in Levels 21 to 18 avoid the thick thigh but are shaped often quite unnatural, sometimes even square. The same goes with the feet, often shaped extremely flat and showing conspicuously marked toes, either grooved or carved normally.

5. The large figures to which the bodily fragments belonged were mostly seated on prefabricated square and hollow *bases*, two specimens of which are selected here. But when wheel-made, the bases are rendered round (cp. no. 183).

a) Fragments of Arms

162. Lower arm with hand of a human figure. Hand-modelled. Five plain bangles adorn the stiffly shaped wrist. The fingers are partly chipped off, they were divided by deep grooves.

L. 8.3 cm. Colour: red-brown. No. So III A 2637.
FS. 2 V 12.3/Cb 12.0, H. 19.45 m. Kṣatrapa. L.23

163. Wrist and hand of a human figure. Hand-modelled. One plain but bulgy bangle. Fingers marked by grooved lines.

L. 5.6 cm. Colour: brown. No. So III A 2561.
FS. 2 V 13.0–15.0/Cb 15.8–16.2, H. 19.60–19.25 m.
Kṣatrapa. L.23

164. Curved arm of human figure. Hand-modelled. Tapering towards the hand. Two plain bangles. Hand shaped like a claw.

L. 5.1 cm. Colour: brown. No. So III A 2455.
FS. 2 V 2.0–10.5/Ca 9.5–11.1, H. 20.55–20.35 m.
Late Kṣatrapa/Early Kuṣāṇa. L.23/22

165. Curved hand-modelled arm of human figure. Tapering towards the hand. One plain bangle. Hand shaped like a closed fist without partition of the fingers.

L. 6.0 cm. Colour: brown. No. So III A 3214.
FS. 2 IV 8.8–10.5/Ca 13.9–19.0, H. 21.55–21.30 m.
Kuṣāṇa. L.21

166. Wrist and hand of right arm of a human figure. Hand-modelled. Two plain bulgy bangles. Hand bent, partition of fingers worn, thumb broken off.

L. 6.9 cm. Red, traces of dark red slip. No. So III A 1697.
FS. 2 V 18.5/Ca 19.2, H. 21.15 m. Kuṣāṇa. L.21

167. Mutilated left arm of a human figure. Hand-modelled. No bangles on wrist. Hand holds a longish object, presumably a mon-goose purse.

L. 12.3 cm. Colour: brown. No. So III A 2821.
FS. 2 IV 5.5/Cb 1.8, H. 21.55 m. Kuṣāṇa. L.21

168. Lower right arm with hand resting on remains of right leg. Hand-modelled. One bangle, decorated with grooved strokes. Hand encircles an object not identifiable anymore.

L. 13.5 cm. Colour: red. No. So III A 1852.

FS. 2 V 15.8/Ca 10.1, H. 22.00 m. Kuṣāṇa. L.20/19

169. Left arm of a human figure. Hand-modelled. Five grooved lines around lower arm and one bulgy bangle incised with slanting strokes. Hand holds a partly damaged bowl.

L. 9.0 cm. Colour: red. No. So III A 2117.
FS. 2 V 13.0/Cc 8.1, H. 21.12 m. Kuṣāṇa. L.20

170. Mutilated wrist and hand of a human figure. Hand-modelled. Remains of one bulgy plain bangle. Hand holds a bowl.

L. 5.3 cm. Colour: brown. No. So III A 2786.
FS. 2 IV 0.8/Ca 1.3, H. 21.53 m. Kuṣāṇa. L.21/20

171. Lower left arm of a human figure. Hand-modelled. Traces of one incised bangle. The stiffly cut fingers of the hand hold a bowl.

L. 8.7 cm. Colour: red. No. So III A 1810.
FS. 2 V 11.4/Cc 4.1, H. 21.50 m. Kuṣāṇa. L.20/19

b) Fragments of Legs

172. Monstrous leg of a seated human figure. Hand-made. Tapering from thigh to ankle. No anklet. Extremely small foot with traces of indented toes.

H. 7.0 cm. Colour: brown, red slip. No. So III A 3116.
FS. 2 V 10.5/Cb 9.5, H. 19.35 m. Kṣatrapa. L.23

173. Leg of a seated human figure. Hand-modelled. Tapering from thigh to foot. Bulge on thigh seems to be the remains of a hand. One plain applied anklet. Toes of small foot marked by deep grooves.

H. 11.7 cm. Colour: brown. No. So III A 2722.
FS. 2 V 5.5/Cc 4.0, H. 20.00 m.
Late Kṣatrapa/Early Kuṣāṇa. L.23/22

174. Massive leg of a seated human figure. Hand-modelled. Tapering from thigh towards foot. One bulgy but plain anklet. Toes marked by deep grooves.

H. 10.2 cm. Colour: red-brown. No. So III A 2828.
FS. 2 V 7–9/Cb 16.15, H. 19.90–19.70 m. Kṣatrapa. L.23

175. Lower part of a leg of a human figure. Hand-modelled. Misshapen bulgy ankle with applied plain anklet. Flat foot with toes marked by grooves.

H. 5.8 cm. Colour: red. No. So III A 1696.
FS. 2 V 15.4/Ca 10.5, H. 20.70 m. Early Kuṣāṇa. L.22

176. Fragment of a human leg. Hand-modelled. One bangle. Foot crusted.

H. 4.6 cm. Colour: red-brown. No. So III A 2384.
FS. 2 V 14.0/Cb 14.5, H. 20.38–20.10 m. Early Kuṣāṇa. L.22

177. Big human foot. Hand-modelled. Two bangles applied one above the other but connected by grooves. Massive flat foot with grooved toes.

L. 4.0 cm. Colour: dark grey. No. So III A 1723.
FS. 2 V 1.5/Cb 15.5, H. 20.90–20.60 m. Kuṣāṇa. L.21

178. Foot of a human figure. Hand-modelled. Naturally shaped.

L. 5.8 cm. Colour: brown. No. So III A 1746.
FS. 2 V 2.1/Cb 12.3, H. 20.95–20.60 m. Kuṣāṇa. L.21

179. Monstrous human leg. Hand-modelled. Leg and foot rectangularly shaped. No anklet. Toes marked by deep grooves.

H. 7.6 cm. Colour: brown. No. So III A 1022.
FS. 3 II 8.7/Ca 18.0, H. 20.63 m. Kuṣāṇa. L.21

180. Misshapen leg of a seated human figure. Hand-modelled. Almost rectangularly shaped but flatter than no. 179. Disc-like object on knee. Applied plain bangle chipped off now. Toes indicated by grooves.

H. 8.2cm. Colour: red. No. So III A 1555.

FS. 3 I 0.5/Ca 12.0, H. 21.80–21.50m. Kuṣāṇa. L.21

181. Leg of seated human figure. Hand-modelled. Traces of garment hanging over the knee. No anklet. Leg shaped flat and partly rectangular. Foot set off against the leg by an indented line. Toes marked by deep incised strokes into the flat and thick foot.

H. 8.2cm. Colour: brown. No. So III A 2780.

FS. 2 IV 1.3/Ca 13.1, H. 22.20m. Kuṣāṇa. L.20/19

182. Fragment of lower part of a sitting human figure. Hand-modelled, inside pot-shaped. Preserved are two bent legs on a flat pedestal and remains of the mutilated arms resting on the thighs. Legs shaped clumsily (cp. no. 180). Toes indicated by sharply grooved lines.

H. 12.0cm. Colour: red. No. So III A 1313.

FS. 2 IV 18.2/Ca 12.9, H. 22.17m. Kuṣāṇa. L.19

183. Fragment of a seated male figure. Hollow, partly wheel-made. Head, left arm and leg broken off. Mutilated right arm resting on thigh, the hand holding a longish object, presumably a mongoose purse. Leg shaped like nos. 180 and 182. Seat formed like a bowl placed upside-down.

H. 14.8cm. Colour: brown. No. So III A 3327.

FS. 2 IV 5.0/Cc 4.1, H. 16.55–16.25m (deep pit).

On stylistic grounds undoubtedly Kuṣāṇa.

c) Bases of seated Figures

184. Square hollow base with remains of a leg of a seated figure.

7.1 × 6.4 × 4.8cm. Brownish. No. So III A 2421.

FS. 2 V 14.0/Cb 2.0, H. 19.95m. Kṣatrapa. L.23

185. Square hollow base for a seated figure.

8.1 × 6.6 × 5.8cm. Colour: brick-red. No. So II 2452.

FS. 2 V 12.0/Cb 13.3, H. 19.20m. Kṣatrapa. L.23



99



100



102



103



101



104

1



105



106



107



108



109



110



111



112



113



114



116



115



117

1



118



118a



119



121



122



120



123

1



124



125



126



128



127



130



129



131



132



133



134



135

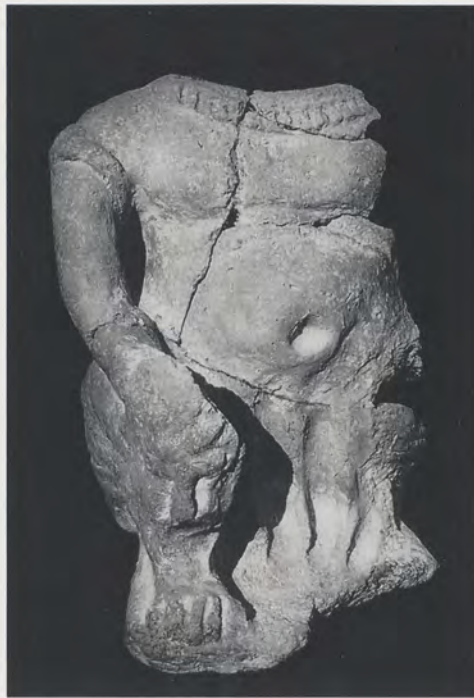

136



137



138



139



140



Pot-bellied Male Figurine. Period V, no. 135

1



141



142



144

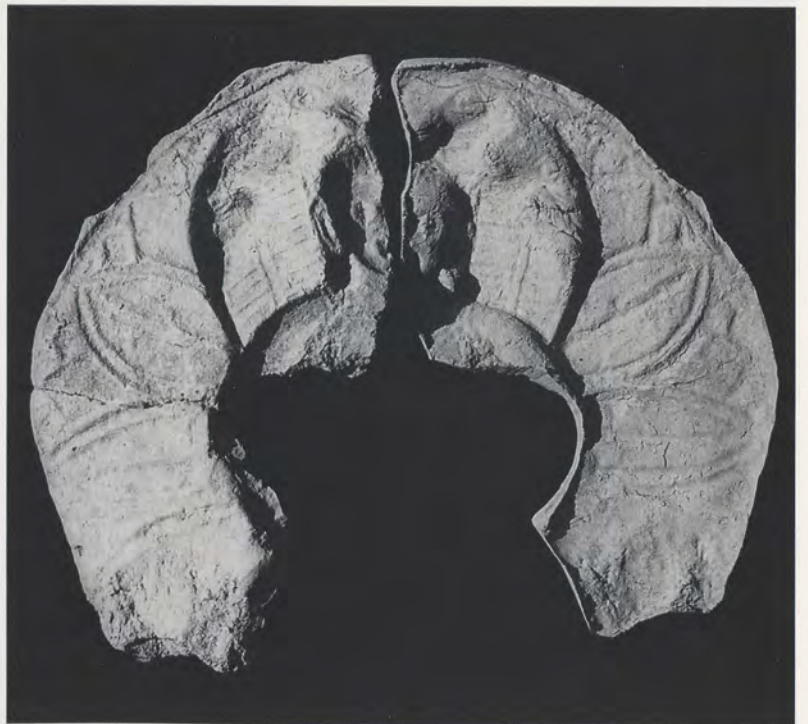

143



145



145 R



146



147



147 R

1



148



149



148 R



150



152



151



153



154



155

1

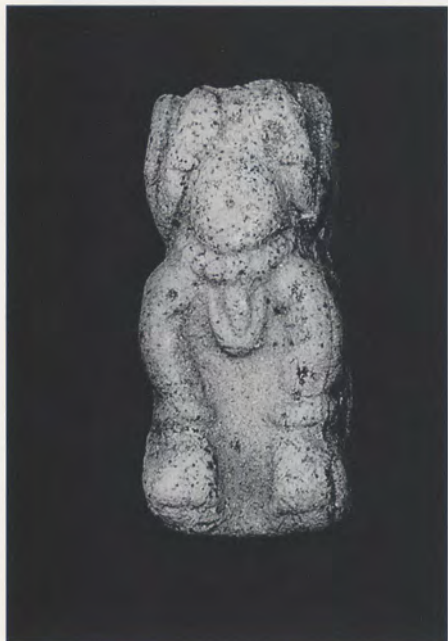

156



157



158

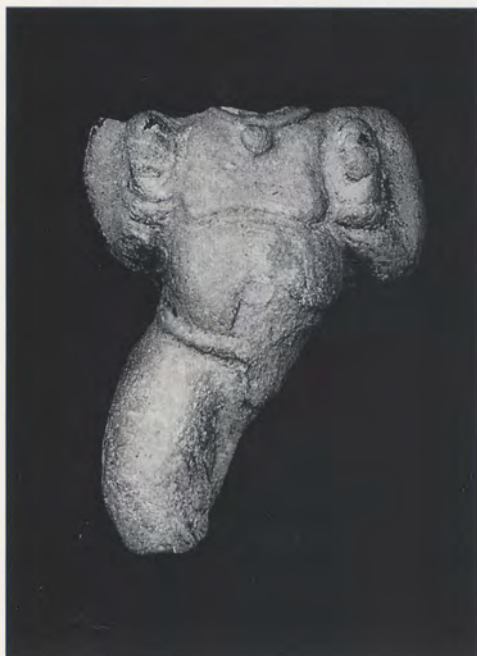

159



160



161

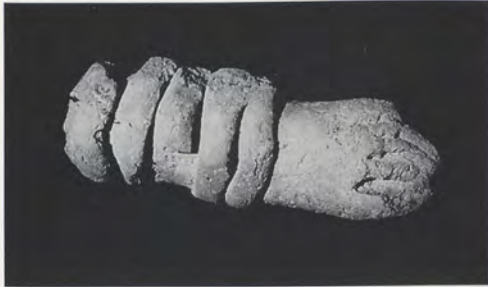

162



163



164



165



166



167



168



169



170



171



172



173

1



174

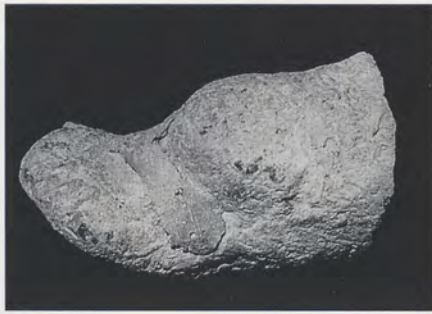

175



176



177



178



179



182



180



181



184



185



183

Periods VI–VIII. Figurines from Levels 15 to 1

The outcome of finds of terracotta figurines and fragments in the horizons above the latest Kuṣāṇa Level 16 is very limited, due to the destruction of structural remains through warlike actions and other catastrophes striking the citadel of Sonkh during the later centuries. Altogether twenty specimens are worth to be described.

The fragment of a larger terracotta relief (no. 186) depicting a Makara, on which presumably the figure of Gaṅgā was standing and, secondly, the very much worn fragment of a female perhaps representing the scene of a woman feeding a parrot with a fruit (no. 187) are doubtlessly of Gupta origin. No specimens of the well-known figures or heads with the typical Gupta hair-dressing have been found in Sonkh. To the Post-Gupta levels belong the fragments of female and male worshippers (nos. 188–89) as well as, already merging into early medieval times, the specimens of couples (nos. 190–91) named as *Sattī-sattā* plaques by V. S. Agrawala, 1948, p. 178.

The only medieval terracotta figures from Sonkh are the paltry lower parts of two more *Sattī-sattā* plaques (nos. 192–93) and the female worshipper of no. 194 together with two fragments of females (nos. 195–96). The latest Period VIII is represented by figures and heads of riders (nos. 197–200) and a variety of male heads (nos. 201–03; 205) of the type with the “blind eyes”.

Period VI. Levels 15 to 12

186. Left lower corner of a terracotta relief showing head, fore-leg and part of the body of a *Makara* in profile. The animal is depicted in a ferocious mood, indicated by the open jaws and the twisted round eyes. All the details, as mouth, teeth, eye, ear, claw, skin-folds and diverse wrinkles are worked out by incisions, the pupil being marked by a deep hole. On the animal's back stand the remains of a human leg and foot. The left edge of the relief is bordered by a single grooved line. Iconographically the relief might have depicted the goddess Gaṅgā on her *vāhana*, the *Makara*.

19.0 × 19.0 × 8.5 cm. Brick-red. No. So I 127.
FS. 2 V 10.2/Ca 6.15, H. 24.50 m. Gupta. L.14

187. Fragment of a female figure. Moulded. Face and one breast damaged. Right arm lowered to a bulgy elevation joining the thigh. Left arm bent, hand near belly. Surface too much worn to recognize details. Perhaps the scene of woman feeding a parrot with a fruit.

H. 8.5 cm. Colour: light brown. No. So III A 684.
FS. 2 IV 3.6/Ca 19.8, H. 24.50 m. Gupta. L.14/13

188. Lower part of a female figure standing on a base plate. Garment consisting of a long dress being flounced at the lower end. Remains of the upper scarf visible on the woman's left side.

H. 4.3 cm. Colour: light brown. No. So III A 907.
FS. 2 V 7.5/Cc 5.0, H. 23.60–23.00 m. Gupta. L.14

189. Fragment of a plaque showing a female figure wearing a long dress reaching down to the feet. The ends of the scarf are hanging to the sides of the legs standing on a flat base plate. Most of the details are blurred by the crusted surface. The right hand seems to hold a fruit, the left is placed on the hip.

H. 7.0 cm. Colour: brown. No. So III A 508.
FS. 2 V 12.9/Ca 17.8, H. 23.00 m (pit). Late Gupta.

190. Mutilated fragment of a *Sattī-sattā* plaque, showing a man and remains of a woman standing side by side. They stand facing, with the left arm of the male and the right arm of the woman crossing at the back, the hands placed on each other's shoulder.

The male, standing to left, wears plain hair with a turban-like bulge. All other details are blurred. Plaque presumably rounded on top.

H. 4.4 cm. Colour: light brown. No. So I 91.
FS. 2 IV 2.5/Ca 14.0, H. 24.75–25.05 m. Post-Gupta. L.12

191. Fragment of a *Sattī-sattā* plaque as no.190. Crudely styled couple with man to left. Arms crossing at the back as before, hands on each other's shoulder. Plaque rounded on top.

H. 4.5 cm. Colour: brown. No. So III A 584.
FS. Filling in 2 IV/Ca, H. 23.70–24.00 m. Post-Gupta.

Period VII. Levels 11 to 8

192. Lower portion of a *Sattī-sattā* plaque. Legs and right arm of a man standing to left. Woman from waist to feet clad in a long garment reaching to the ankles. Left arm hanging down. Grooved lines border the plaque.

H. 3.2 cm. Colour: light brown. No. So III A 304.
FS. 7.5–9.5/Ca 14.0–19.5, H. 24.85–25.15 m.
Early Medieval. L.12/11

193. Lower half of a *Sattī-sattā* plaque. Surface corroded. Preserved are the legs of the man with his right hand on the thigh. The woman stands to right wearing a long garment reaching down to the ankles. Left hand is visible on her thigh. Plaque being framed by a border of two parallel grooved lines. Base partly broken off.

H. 4.7 cm. Colour: grey-brown. No. So III A 287.
FS. 2 IV 3.0/Ca 8.55, H. 25.45 m. Medieval. L.11

194. Plaque showing a standing female. Thickset figure with large head but corroded face. Head-dress consisting of some sort of a crown adorned with a triangular jewel. Plain ear-rings, necklace. Figure clad in a short lower garment, the shawl-ends of which are hanging over the lower arms. In the middle of this skirt-like dress a thick vertical fold is shown. The arms are bent, the hands holding objects: the left hand a cup or small bowl, the right a corroded something. The feet under the edge of the garment are given as stumpy rectangles. The figure stands on a protruding base of the plaque which in itself is tapering towards the rounded top. Back flat.

H. 9.3 cm. Colour: light brown. No. So I 86.
FS. 2 IV 7.48/Ca 12.03, H. 24.95 m. Medieval. L.11

195. Weatherworn lower portion of a plaque with the legs and feet of a woman exactly like no.194. To the sides the shawl-ends of the garment.

H. 4.5 cm. Colour: light brown. No. So III A 901.
FS. 2 IV 0.5–9.5/Ca 19.5-Cb 0.5, H. 24.86–25.21 m.
Medieval. L.11

196. Fragment of a female figure. Preserved is the lower part of the legs covered with a long dress under which the feet are visible on a rounded base-plate. On the side of the left leg a corner of the upper garment is hanging down.

H. 4.0 cm. Colour: brown. No. So III A 244.
FS. 2 IV 5.5–9.5/Ca 0.5–9.5, H. 25.80–26.40 m.
Late Medieval. L.(9)/8

Period VIII. Levels 7 to 1

197. Head of a rider. Long-drawn face, broad mouth, thick nose and protruding eyes under curved eyebrows. On top a flat bowl-shaped cap. Back of head flat.

1 H. 4.0 cm. Brown, traces of black paint. No. So III A 161.
FS. 2 IV 8.12/Ca 13.72, H. 26.25 m. Jat. L.6/5

198. Rider on horse. Head of the man exactly of the type of no.197. Upper body ascending directly from the animal's back with arms curved and hands touching the horse's neck. The horse itself is going to be described under ANIMAL FIGURES.

H. (with horse) 14.1 cm. Red-brown. No. So I 102.
FS. 2 IV 19.9/Ca 14.06, H. 25.35 m (pit from L.5). Jat.

199. Head of a rider with flat bowl-shaped cap as no.197.
H. 4.7 cm. Colour: red-brown. No. So III A 541.
FS. Filling. Out of context.

200. Mutilated bust of a rider as nos.197–199.
H. 6.2 cm. Colour: red-brown. No. So III A 171.
FS. Surface find. Out of context.

201. Head of a man with blade of a sword. Protruding "blind" eyes in a face with plump cheeks, broad nose and thick lips. To the side of lips a pricked hole each. Of the hair-dress a bulgy ribbon is preserved. The blade of the sword touches the head. Back of head chipped off.

H. 4.8 cm. Colour: red-brown. No. So III A 535.
FS.2 III 19.5/Ca 3.46, H. 25.40 m (pit from L.5). Jat.

202. Head of a male figure. Head-dress chipped off. Large, protruding eyes, broad nose and mouth, thick lips. Long neck. Pupils painted. Right ear sticking out, small ear-ring.

H. 4.5 cm. Brown with red paint. No. So III A 143.
FS. 2 V 3.32/Ca 15.22, H. 26.45 m. Jat. L.5

203. Head of a male figure. Facial features as no.202 with large and protruding "blind" eyes. Head-dress shaped like, or covered by, a flat cap.

H. 3.7 cm. Colour: dirty brown. No. So I 56.
FS. 2 V 3.95/Cb 8.44, H. 27.00 m. Jat. L.4

204. Head of a child. Plump face with extremely small mouth. Remains of curly hair. Back unmodelled.

H. 4.1 cm. Colour: red. No. So I 3.
FS. Uppermost wall in 3 I/Ca. Jat. L.3–1

205. Head of a male figure with longish head and facial features as nos.202–203. Small right ear. Broadbrimmed conical hat. Pointed tenon for insertion into a separately shaped body.

H. 5.3 cm. Colour: grey. No. So III A 3258.
FS. Ditch find. Out of context but certainly Jat.



186



187



190



191



188



189

1



192

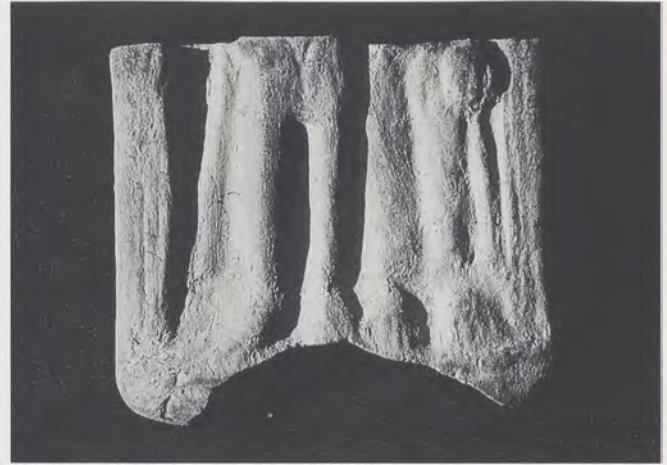

193



194



195



196



197



198



199



200



201



202

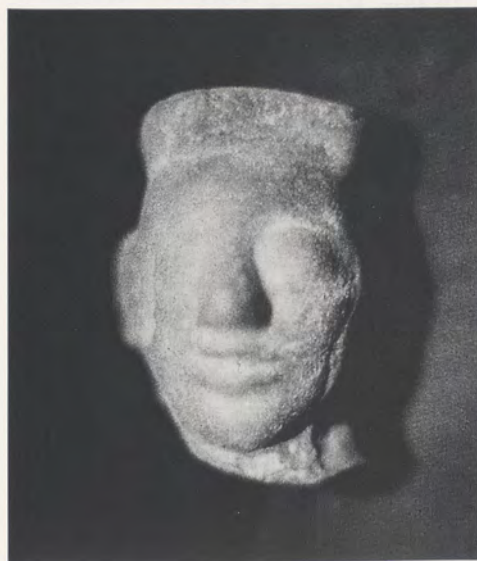

203



204



205

TERRACOTTA HUMAN FIGURINES: APPENDIX 1

Nude Dwarfish Male Figures

As mentioned in a postscript to no. 78 first specimens of a type of nude dwarfish male figures appear in Sonkh as early as Period III but have been found furthermore in most levels of the Periods IV and V. This type is iconographically different from that of the Boyish Figures (nos. 156–161) the finds of which are restricted to the Kuṣāṇa times. Because of the relatively long lasting occurrence of the nude dwarfs through at least three periods in Sonkh this group has been separated and is going to be dealt with here as Terracotta Appendix 1.

The normal type is that of a naked bow-legged male figure with feet joined so that the legs roughly form a rhombus. The space in between the legs is, as a rule, filled with a thin layer of clay on which the genitals are conspicuously displayed. The only exception is the oldest piece found in Level 26 (no. 206) showing a rhomboid free space instead of a clay filling. Unlike the Boyish Figures mentioned above the Nude Dwarfs are normally not really pot-bellied. As far as the mostly headless finds permit a reconstruction, the figures are depicted with shaven head, sometimes with a pointed skull, and short projecting ears. The hands are throughout shown as clenched fists.

Most of the figures are solid and made from two moulds. None of the pieces shows the “round holes pierced between the flexed elbow and the armpit” as in the comparable types from Ahichchhatra (V. S. Agrawala, 1948: pl. XXXVI, p. 119).

The different positions of the hands help to classify the figures under the following subtypes:

1. Clenched fists near hips and groin
2. Clenched fists near waist
3. Clenched fists on chest
4. Right fist on chest

The earliest piece of a nude dwarfish figure appears, as already mentioned, in Level 26, i.e. the time of the Mitras of Mathura. The most frequent finds come from the Kṣatrapa Level 23. The occurrence of the type ends in the latest Kuṣāṇa Level 16.

Subtype 1: Clenched Fists near Hips and Groin

206. Headless, bow-legged nude dwarfish male figure with open space between the legs. Heels joined, arms lowered, clenched fists placed near the hips and groin. Genitals worn. Traces of decorative ribbons below neck and around waist. Back modelled by a second mould.

H. 12.1 cm. Colour: grey, dirty. No. So III A 2372.
FS. 3 I 3.5/Cb 4.0, H. 18.70 m. Mitra. L.26

207. Mutilated fragment of a nude dwarf, made from two moulds. Head and legs broken off. Arms lowered, clenched fists near the hips and groin. Remains of the genitals.

H. 6.7 cm. Red, traces of red paint. No. So III A 1346.
FS. 3 II 8.1/Ca 18.8, H. 19.05 m. Mitra. L.25

208. Mutilated fragment of a bow-legged nude dwarfish male. Made from two moulds. Found in two pieces from different find spots. Head, right arm and feet broken off. Arms lowered, clenched fists near the hips and groin. Flat piece of clay between the legs. Genitals clearly displayed. Buttocks conspicuously carved.

H. 8.6 cm. Colour: red. No. So III A 1759.
FS. 3 I 1.0–4.0/Ca 5.0–9.8, H. 19.90–20.14 m.

3 I 2.2/Ca 8.6, H. 19.80 m. Early Kṣatrapa. L.24

209. Fragment of a bow-legged nude dwarf without head and feet. Made from two moulds. Arms curved, clenched fists placed near the hips and groin. Worn genitals on flat piece of clay between the remains of thighs.

H. 5.2 cm. Colour: grey-brown. No. So III A 2831.
FS. 2 V 2.5–5.0/Cb 10.5–12.6, H. 19.80–19.95 m.
Kṣatrapa. L.24/23

210. Fragment of a nude dwarfish male. Made from two moulds. Head and legs broken off. Arms lowered, clenched fists near the hips and groin. Remains of part of the genitals.

H. 4.5 cm. Grey, traces of white paint. No. So III A 2782.
FS. 2 V 5.5/Cc 4.0, H. 19.70 m. Kṣatrapa. L.23

a) Fragment of bow-legged feet with space of clay and lower part of the genitals.

H. 4.3 cm. Colour: grey. No. So III A 2383.
FS. 2 V 14.1–15.7/Cc 3.2–5.0, H. 19.80–20.10 m.
Late Kṣatrapa/Early Kuṣāṇa. L.23/22

211. Fragment of bow-legged nude dwarf. Made from two moulds. Head and lower legs broken off. Chest slightly modelled. Right arm and thigh damaged. Clenched fists near hips and groin. Genitals above space of clay between thighs.

H. 11.3 cm. Colour: red-brown. No. So III A 3170.
FS. 2 III 9.78/Cc 7.18, H. 21.64 m. Kuṣāṇa. L.20/19

212. Mutilated bow-legged nude dwarf. Head, right leg and lower left leg broken off. Tall upper body. Cross-shaped navel? Arms bent, clenched fists near hips and groin. Traces of genitals on damaged space of clay between legs. Back roughly modelled.

H. 6.7 cm. Colour: red. No. So III A 1155.
FS. 3 I 4.0–6.0/Ca 19.5–Cb 0.5, H. 22.80–23.70 m.
Late Kuṣāṇa. L.16

Subtype 2: Clenched Fists near Waist

213. Bow-legged nude dwarfish male figure. Made from two moulds. Surface corroded. Bald head with skull pointed at the back. Arm bent with clenched fists placed near the waist. Genitals above space of clay between legs. Feet broken off.

H. 5.8 cm. Colour: brown. No. So III A 3056.
FS. 2 V 10.2/Cb 6.3, H. 19.48 m. Kṣatrapa. L.23

214. Fragment of mutilated nude male figure. Head and legs broken off. Round navel. Arms bent with clenched fists near the waist.

H. 5.4 cm. Colour: brown. No. So III A 3005.
FS. 2 IV 12.2–14.5/Ca 6.2–9.5, H. 21.00–21.12 m.
Kuṣāṇa. L.(22)/21

215. Bow-legged nude dwarfish male. Made from two moulds. Lower legs broken off. Bald head, chest and back modelled. Round navel. Arms bent, clenched fists raised near to the waist. In the hip area incised horizontal line indicating belt. No such incision on the back. Genitals clearly displayed above space of clay between thighs.

H. 8.8 cm. Brick-red, whitish paint. No. So I 179.
FS. 2 IV 12.2/Cc 1.1, H. 21.36 m. Kuṣāṇa. L.20

Subtype 3: Clenched Fists on Chest

216. Corroded fragment of a bow-legged nude dwarfish male figure. Made from two moulds. Head and part of left leg broken off. Arms bent with clenched fists on the chest. Remains of genitals on space of clay between legs.

H. 4.9cm. Brown, traces of white paint. No. So III A 1719.
FS. 3 I 5.7/Ca 7.0, H. 19.95m. Early Kṣatrapa. L.24

217. Corroded nude male. Legs broken off. Long protruding ears give head triangular shape. Arms bent with clenched fists on chest. Paunchy abdomen. Remains of genitals.
H. 5.4cm. Colour: brown. No. So III A 2899.
FS. 2 V 9.6/Cb 7.25, H. 19.55m. Kṣatrapa. L.23

218. Fragment of a nude dwarfish male figure. Made from two moulds. Head and legs broken off. Paunchy abdomen. Arms bent, clenched fists on breast.
H. 6.6cm. Colour: brown. No. So III A 2796.
FS. 2 III 12.0/Cc 4.5, H. 21.60m. Kuṣāṇa. L.20/19

219. Fragment of a nude dwarfish male figure as before.
H. 6.1cm. Colour: red. No. So III A 980.
FS. 2 IV 6.15/Cb 19.93, H. 23.12m. Kuṣāṇa. L.17

a) Mutilated fragment of a nude dwarfish male with clenched fists on the chest.
H. 8.8cm. Colour: brown. No. So III A 3190.
FS. 2 III 9.5/Cc 7.2, H. 21.05m. Kuṣāṇa. L.21

Subtype 4: Right Fist on Chest

220. Headless naked bow-legged male figure. Right arm bent with clenched fist on chest. Left arm lowered, hand resting on thigh. Round navel. Genitals on space of clay between legs. Feet broken off.
H. 11.4cm. Colour: brown. No. So III A 2730.
FS. 2 V 8.75/Cc 3.0, H. 19.58m. Kṣatrapa. L.23(2)

Miscellaneous Fragments

221. Lower portion of figure showing moulded buttocks and bowed legs with plain space of clay in between. Feet broken off.
H. 6.2cm. Colour: brown. No. So III A 2151.
FS. 2 IV 10.75/Ca 6.1, H. 19.94m. Kṣatrapa. L.23

222. Corroded back of a bow-legged nude figure. Head and legs broken off. Arms bent. Buttocks marked. Remains of plain space of clay between thighs.
H. 6.1cm. Colour: grey. No. So III A 3395.
FS. 2 V 5.5/Cb 18.2, H. 19.22m. Kṣatrapa. L.23

a) Corroded back as no. 222.
H. 6.3cm. Colour: brown. No. So III A 648.
FS.2 III 17.8/Ca 13.9, H. 23.75m. Late Kuṣāṇa. L.17/16

223. Head of a male figure. Round face, protruding ears and shaven skull as with the bow-legged nude dwarfs.
H. 3.0cm Colour: yellowish. No. So I 361.
FS. 2 V 6.7/Cb 17.9, H. 18.85m. Late Mitra. L.25

224. Corroded head with protruding ears as before.
H. 3.9cm. Colour: brown. No. So III A 2132.
FS. 2 V 13.7/Ca 19.15, H. 20.10m. Kṣatrapa. L.(24)/23

225. Head of a male figure as nos. 223–224.
H. 3.3cm. Colour: red. No. So III A 3123.
FS. 2 V 9.8/Cb 16.8, H. 19.25m. Kṣatrapa. L.23

226. Corroded head of a male figure as before. Made from two moulds. Distinct cleft running behind ears around the back of the head.
H. 3.5cm. Colour: light brown. No. So III A 1045.
FS. 2 IV 13.5/Ca 15, H. 22.50–22.80m. Kuṣāṇa. L.19/18

227. Dwarfish male figure. Different from the types of the nude dwarfs or the boyish figures with bell-necklace. Face shows pricked pupils. Head-dress consists of a turban with central bulge. Figure wears ear-rings and a long three-stringed necklace with cylindrical pendants. Hands seem to touch each other above pot-belly. Remaining thighs have bow-legged position with plain space of clay in between and genitals upon it.
H. 7.0cm. Red, traces of mica. No. So I 205.
FS. 8.5/Cc 5.9, H. 21.55m. Kuṣāṇa. L.20/19

1



206



207



208



209



210

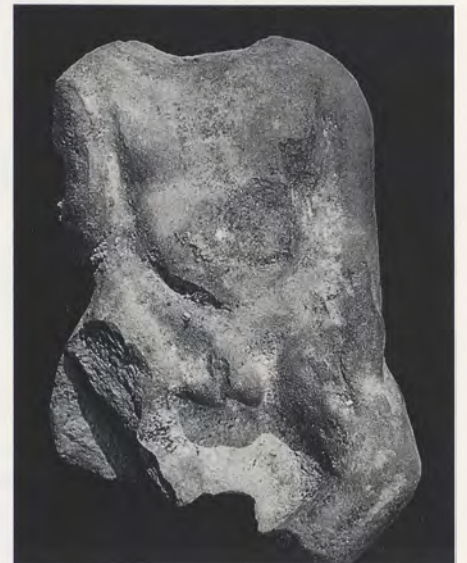

211



212



213

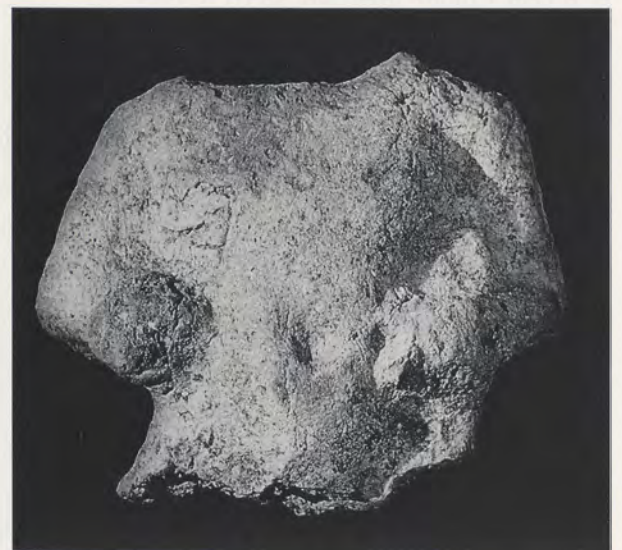

214

Terracotta Nude Dwarfish Male Figures



215



216



217



218

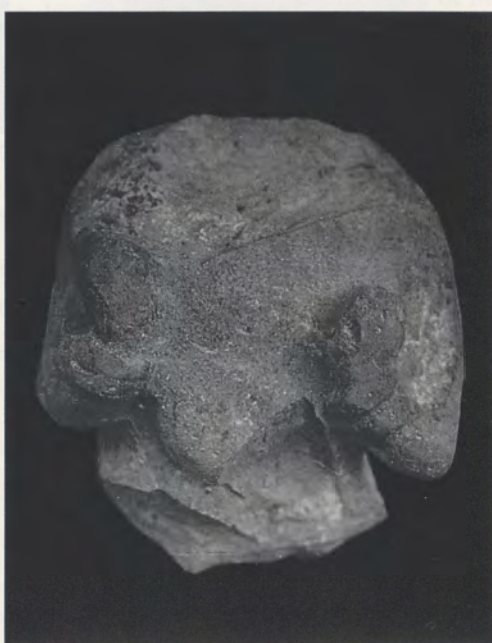

219



220

1



221



222



223



224



225



226a



226b



227

TERRACOTTA HUMAN FIGURINES: APPENDIX 2

Tribal Figures

The terracotta figurines nos. 1–227 represented art objects which, one way or the other, were links of a chain strung together during the times of constant development of the terracotta art in Sonkh and which on the basis of its stratigraphic datas could be classified according to style, iconography and fabric. But there remains a group of hand-made figures and fragments so much different from the normal products that they had to be separated from the main strand. The divergence is caused by the simple fact that these terracottas have been formed by people who were no artists and, in a part, by children, and therefore represent figures which are individual products and in this sense unique. They are not “timeless” but embedded in the stream of everlasting activities century after century. Although presented here entirely according to their stratigraphic provenance, these figures from Sonkh prove that a “Zeitgeist” is immanent even in such undeniably poor products. In want for a more appropriate word the term “tribal” has been accepted for this individualistic type of art production and will be used here too, but one should always be aware of its wider meaning beyond the limited sense of the word.

228. Bust of a female figure. Right side of face and right arm broken off. Remaining part of face shaped similar to beak-type figures with dominating pinched out nose. Eyes and mouth indicated by concave impressions. Large loop applied at the side of left ear. Collar and part of necklace chipped off. The breasts are placed unbalanced. Left arm stretched sideward.

H. 7.3 cm. Colour: grey. No. So III A 2996.

FS.2 IV 9.0/Be 18.2, H. 18.85 m. Advanced Śuṅga C.P., L.30

229. Fragment of a rider. Shapeless face dominated by broad horizontally cut mouth. Figure wears sort of a turban and a bulgy necklace. Arms broken away. Cavity between thighs extends as deep cleft up to the stomach (cp. nos. 58 ff.).

H. 7.1 cm. Colour: brown. No. So III A 3678.

FS. 2 IV 1.4/Cc 3.5, H. 17.86 m. Mitra. L.27/26

230. Upper part of a female figure. Head without head-dress. Mammoth eyes and mouth carelessly hollowed out. Left arm stretched sideward, partly broken off right arm presumably held forward. Remnants of applied breasts.

H. 5.6 cm. Colour: brown. No. So III A 3645.

FS. 3 I 1.3/Cb 9.9, H. 18.15 m. Mitra. L.27/26

231. Bust of human figure. Pinched out face, mutilated nose-ridge extending up to the head. Mouth presumably indicated by a depression. Eyes marked by vertically scratched eyelids and pricked pupils. Arms were stretched forward (as with riders) but now broken off.

H. 5.3 cm. Colour: brown. No. So III A 1957.

FS. 3 I 3.3/Ca 14.5, H. 19.65 m. Late Mitra. L.25

232. Head of a male figure. Eyes applied as large patches with pricked pupils. Broad nose with pierced nostrils. Mouth above long-drawn chin marked as a grooved hole. Ears protruding to the sides, adorned with small round ear-rings. From upper edge of left ear winds a strand of hair down to the neck. Head-dress wound like a turban cloth. Back unmodelled.

H. 5.0 cm. Colour: grey-black. No. So I 198.

FS. 3 II 19.2/Ca 5.0, H. 19.98 m. Early Kṣatrapa. L.24

233. Flat female figure. Pinched out nose dominates the face. Nearly invisible eyes marked as small encircled pricks. Ears pro-

truding straight to the sides. In place of mouth a shallow depression. Traces of hair on the head. Stumpy arms stretched out to the sides. Small pointed breasts. Broad round hips and parted shortened legs. Back flat.

H. 15.0 cm. Colour: brick-red. No. So I 298.

FS. 2 IV 5.8/Be 17.7, H. 20.40 m. Early Kṣatrapa. L.24/23

234. Bust of a female figure. Face marked as a large grooved shallow depression. Head-dress and ears indicated as protruding parts of the head. Short stumpy arms stretched out to the sides. Applied breasts mutilated. Back unmodelled.

H. 5.5 cm. Colour: brown. No. So III A 2907.

FS. 2 V 14.3/Cc 2.5, H. 19.05 m. Early Kṣatrapa. L.24

235. Head of a human figure. Broad face with protruding ears similar to the type of nude dwarfish males. Long-drawn eyelids, mutilated nose, thick-lipped mouth. Presumably bald head.

H. 4.8 cm. Colour: brown, white paint. No. So III A 2997.

FS. 2 V 0.9/Cb 13.5, H. 19.15 m. Early Kṣatrapa. L.24

236. Crusted and worn seated human figure. Right arm stretched forward, left arm kept in a lowered position. Parted stumpy legs. Head partly damaged. Pinched out face, deep-set grooved eyes.

H. 8.7 cm. Colour: red under mud. No. So III A 1693.

FS. 3 I 8.2/Ca 8.3, H. 20.65 m. Kṣatrapa. L.23

237. Crude male figure. Damaged head shows remains of applied eyelids. Large nose above broad-cut mouth. Right ear-ring preserved. Cap-like head-dress with traces of adornments. Left arm broken off. Right arm bent towards chest. Plump body, deep-bored navel with thrown-up edges. Legs missing.

H. 12.0 cm. Colour: brown. No. So III A 2772.

FS. 2 V 13.5/Cb 12.2, H. 19.30 m. Kṣatrapa. L.23

238. Fragment of a human figure. Pinched out face with no markings of eyes. Nose-ridge extends right up to the pyramidal protuberance of head. Traces of a depression in place of mouth. No decorations. Large deep-bored navel with thrown-up edges.

H. 5.6 cm. Colour: brown. No. So III A 3264.

FS. 2 IV 15.1/Cc 6.2, H. 17.75 m (ditch from 23).

Kṣatrapa. L.23

239. Mutilated seated figure which because of the size of the applied breasts might be taken as a female. The face shows pricked eyes, a long nose with clear nostrils and pouted lips. The protruding ears are pierced at the upper edge. The figure wears a bulgy necklace and an *upavīta*, the latter reaching from left shoulder to right hip. The arms are stretched forward. A flatly hollowed navel is visible above the parted but broken off legs. A special feature of this figure is a hood raising from the middle of the back in a fan-like shape upwards to the back of the head spreading there like a halo. The way this hood is applied permits one to identify the figure as that of a Nāginī (or perhaps Nāga).

H. 12.5 cm. Colour: Red with red slip. No. So I 282.

FS. Stray find. On the analogy of the Mother Goddess figures from votive tanks from the Levels 24/23 (nos. 79 ff.) this piece has to be dated to the Kṣatrapa period.

240. Bust of a female figure. Dominant nose reaching from mouth to ribbon around head. Eyes applied as round patches. Breasts and right arm broken off. Left arm lowered in bent position.

H. 6.6 cm. Grey-brown, black slip. No. So III A 1854.

FS. 2 IV 5.1/Cb 18.5, H. 21.05 m. Kuṣāṇa. L.22/21

241. Corroded head of a human figure. Broad face with protruding ears. Eyes applied as lenticular lids with pricked eyeballs.

1 Mutilated nose extends up to hair-level. Nostrils indicated by pricked holes. Mouth shaped as a round cavity. Necklace decorated with punched holes.

H. 13.0 cm. Colour: brown. No. So III A 1666.

FS. 2 V 14.3/Ca 8.5, H. 20.70 m. Early Kuṣāṇa. L.22

242. Bust of a female figure. Crudely shaped face: nose indicated as a deep cavity, eyes as flat round dips and mouth as a large hole. Stumpy arms stretched out to the sides, wearing one plain armlet. Applied breasts unbalanced.

H. 6.1 cm. Colour: brown. No. So III A 2177.

FS. 2 V 9.0/Ca 19.3, H. 20.70 m. Early Kuṣāṇa. L.22

243. Curiously shaped female figure. Mouth and nose indicated as large cavities, eyes scratched slantingly in the narrowing edges of the face. Breasts given as longish depressions. Right arm bent towards hip, lowered left arm broken off. Area of the armpits perforated.

H. 5.5 cm. Colour: grey-black. No. So III A 1420.

FS. 2 V 2.8/Ca 4.8, H. 21.13 m. Kuṣāṇa. L.21(1)

244. Seated male figure of grotesque build. Broad cheeks, narrow forehead. Huge dominating nose. Preserved right eye applied. Mouth depicted as a triangular cavity, under the nose a horizontally scratched line indicating a moustache. Left lower arm broken off. Right arm bent forward holding a round object decorated with punched circlets in his hand (shield?). The stomach seems to be sunk. Both legs broken off.

H. 8.7 cm. Colour: brown. No. So III A 1247.

FS. 2 V 19.2/Ca 17.1, H. 21.60 m. Kuṣāṇa. L.21(2)

245. Bust of a female figure. All details of the face and the decorations crudely applied. On top some sort of a diadem. Around the neck a necklace consisting of a chain of round discs. From the left shoulder winds an *upavīta* down between the conspicuously applied breasts.

H. 7.5 cm. Colour: brick-red. No. So 338.

FS. 2 IV 10.5/Ca 13.2, H. 21.75 m. Kuṣāṇa. L.21

246. Bust of a human figure. Crudely pinched out face with dominating nose, receding cheeks and an edgy forehead under which the eyes are indicated as vertically incised strokes. To the right a pointed bulge on head. Mouth seems to have been given as a flat depression under the nose-wings. Right arm broken off, left arm bent downwards.

H. 3.5 cm. Colour: grey. No. So III A 2936.

FS. 2 IV 6.1–9.5/Cb 5.0–6.5, H. 21.30–21.15 m.

Kuṣāṇa. L.21

247. Upper half of a curiously shaped human figure. The head shows (visible on the left) an inverted face with eyes and mouth indicated by pricked holes. A large ring adorns the left ear, a pendant hangs in the right one. A sort of crown consisting of perforated peaks covers the head. The body is heavily smeared, the left arm broken off. The stumpy right arm is slightly bent and shows armlets.

H. 6.25 cm. Colour: grey. No. So III A 1396.

FS. 2 IV 0.5/Cb 10.5, H. 21.85–21.55 m. Kuṣāṇa. L.21/20

248. Fragment of a male figure (rider?). Simple pinched out face with dominating nose. No eyes indicated. Mouth shaped as a shallow round depression. On top a turban-like head-dress. Broken off arms were originally stretched forward.

H. 7.8 cm. Colour: red. No. So III A 2701.

FS. 2 III 10.5/Cb 16.5, H. 21.90–21.60 m.

Kuṣāṇa. L.20

249. Crudely shaped *Ekamukhalinga*. Eyelids smeared towards the sides, pupils presumably pricked. Mouth below huge nose given as a hole. An *upavīta* hangs slanting from right to left on the linga-shaft.

H. 10.8 cm. Colour: grey. No. So III A 1235.

FS. 2 IV 12.2/Cc 5.8, H. 21.40 m. Kuṣāṇa. L.20

250. Fragment of a hand-made plaque showing a female figure. Right arm bent, palm of the hand facing upwards. Left arm lowered to the hip. Crudely shaped face with pricked eyes and nostrils. Head-dress and right ear-ring showing incised decor. Traces of a necklace. Breasts and navel pricked. Girdle and short dress marked by incised lines.

H. 11.4 cm. Colour: red. No. So I 235.

FS. 2 IV 10.4/Ca 9.0, H. 22.28 m. Kuṣāṇa. L.19

251. Head of a human figure. Eyes and nose applied to an otherwise plain tapering head-piece of clay. Mouth incised as a sharp horizontal stroke. At the lower edge a spot of fracture to the left. Therefore an identification as *Ekamukhalinga* seems to be out of question.

H. 5.2 cm. Colour: red. No. So III A 1360.

FS. 2 III 15.8/Ca 14.8, H. 22.64 m. Kuṣāṇa. L.19

252. Seated male (?) figure. Upper part of face broadly extended to the sides including the ears. Lower face consisting of a very narrow chin with open mouth and protruding tongue. Eyelids applied lenticularly, pupils pricked in disc-shaped iris. Head ends in a protuberance on top. A plain necklace hangs down over the nipples. The whole left and the lower right arm as well as both legs are broken off. The right arm extended towards the knee. The figure is pot-bellied with large navel pit. At the bottom part of the round stand is visible.

H. 21.8 cm. Colour: red. No. So III A 1073.

FS. 2 III 18.4/Ca 18.2, H. 22.90 m. Kuṣāṇa. L.19

253. Head of a male figure. Narrow forehead with broken off protuberance above it. Eyes incised under edging brows. Nose with nostrils mutilated. Applied moustache above bordered mouth. Ears protruding to the sides reaching from the level of the forehead down to that of the chin.

H. 10.1 cm. Colour: brown. No. So III A 1292.

FS. 2 IV 4.2/Cb 10.8, H. 22.25 m. Kuṣāṇa. L.18

254. Fragment of the bust of a male figure. Bald head with protruding long ears. Narrow forehead with sharp-edged brows under which the eyelids are applied around incised eyeballs with pricked pupils. Long dominating nose above bordered mouth which seems to be opened. At the left shoulder hangs a bulgy object, presumably cloth.

H. 6.5 cm. Colour: brown. No. So III A 1039.

FS. 2 III 7.3/Cc 8.2, H. 22.67 m. Kuṣāṇa. L.18/17

255. Head of a human figure. Broad head, face overlapping with the protruding ears. Sharp-ridged nose dominates face up to the forehead. Eyes incised, pupil marked by pricks. Mouth inverted in a shallow depression.

H. 2.6 cm. Colour: brown. No. So III A 1038.

FS. 2 IV 16.5/Ca 17.5, H. 22.75 m. Kuṣāṇa. L.18

256. Mutilated, presumably seated figure of a female. Pinched out face with nose-ridge reaching to the forehead. Eyes and mouth incised. Protruding ears showing a perforation near upper and lower edge. The ridge of the ears extends to the head where it joins the ridge of the nose. The meeting-point is adorned with an applied punctured disc. A necklace consisting of applied round pearls hangs down to the mutilated breasts. Arms broken off.

Traces of a large navel pit. Whole part of legs chipped off. It looks as if legs were bent in seated position. At the back, long strands of hair and a chain of discs hangs down from the head to the otherwise flat rear. Below, a girdle stretches horizontally from hip to hip. The figure ends in two angular stumps. Judging from both the sides, reverse and obverse, one is inclined to see in these stumps stands only for a seated figure, not stumpy legs.

H. 23.0cm. Colour: brown. No. So I 144.

FS.2 IV 9.0/Ca 15.8, H. 23.45m. Late Kuṣāṇa. L.16

257. Fragment of a terracotta plaque showing two female figures side by side and hand in hand. Details of faces and bodies to a large extent corroded. Ear-rings, necklaces and traces of girdles recognizable. Legs slightly bent as if indicating a seated position. Toes crudely marked by incisions. Perhaps part of a *Mātrkā* panel.

H. 19.5cm. Colour: brick-red. No. So I 142.

FS. 2 IV 8.65/Ca 15.3, H. 23.55m. Late Kuṣāṇa. L.16

258. Crudely shaped head with horns of a ram. Eyelids incised nearly parallel, eyeball elevated, pupils pricked. Mouth roughly cut. Ears protruding to the sides. Horns of ram winding from head and behind ears towards mouth. Back unmodelled.

Ht. 9.2cm. Colour: brick-red. No. So I 147.

FS. 2 IV 3.5/Ca 2.15, H. 23.85m. Late Kuṣāṇa. L.16

259. Upper part of a hollow male figure. Crude but expressive work. The laughing face shows a curved nose, large incised eyelids and pricked pupils. The mouth is broadly incised and a moustache indicated by slight scratches. In the right ear a hole is marked. The figure is adorned with some sort of diadem on the head and an incised necklace with pricked holes. The stumpy arms seem to have been raised above the conical upper body.

H. 14.0cm. Colour: brick-red. No. So I 136.

FS.2 IV 13.4/Ca 12.25, H. 24.10m. Late Kuṣāṇa. L.16/15

260. Small figure of Kubera? Long round head with applied eyebrows and eyeballs. Thick nose above small deepened mouth. Head-dress chipped off. Body slightly pot-bellied. Right elbow missing. Both hands raised to chest. Left hand holds an object (purse?). Position of legs unclear, figure perhaps seated. Back unmodelled.

H. 7.4cm. Colour: brown. No. So I 118.

FS. 2 V 6.3/Cb 1.75, H. 24.10m. Gupta. L.14

261. Human head. Long dominating nose. Applied upper eyelids cover two third of the eye, lower lid marked as an upturned edge only. Lips pushed forward. Head-dress and ears broken off.

H. 4.5cm. Colour: brick-red. No. So III A 413.

FS. 2 V 9.0/Ca 2.5, H. 24.45m. Gupta. L.14

262. Three-legged headless female figure with dangling breasts. Thin arms lowered, hands placed together upon stomach. Left leg broken away, stump of third leg on back.

H. 8.5cm. Colour: brown. No. So III A 437.

FS. 2 III 19.8/Cb 12.0, H. 26.35m. Filling.

263. Plaque showing kneeling hunter with bow and arrow in shooting position on the one, and an unidentified animal on the other side.

H. 12.3 × 8.4cm. Colour: red. No. So III A 6.

FS. Surface find. Out of context. Late.

1



228



229



230



231



232



234



235



236



233



237



238



239



240



241



242



243



244

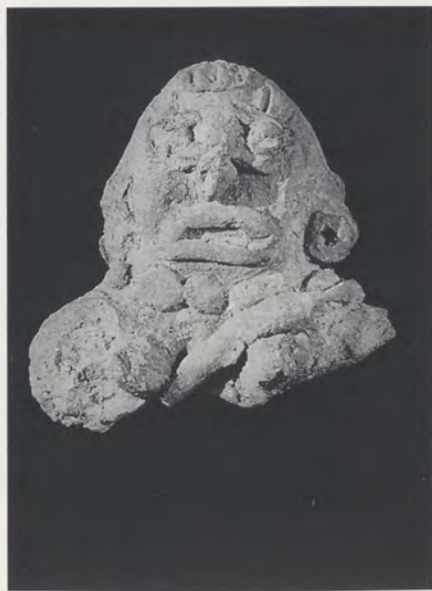

245

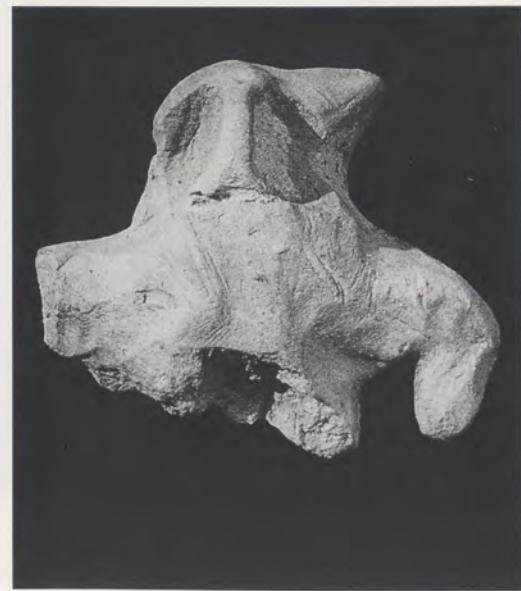

246

1



247



248



249



250

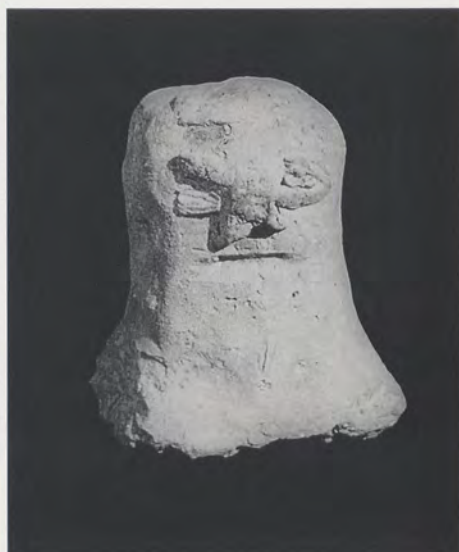

251



252



253



254



255

27 Terracotta Animal Figurines

The examples include 30 animal groups and figurines of 100% of which are to be identified and named as follows:



256a



256b



257

Kam
Autopsy
Lince
Indigum



259a



259b

with the VII and VIII and the first three pieces. The animal and human forms have been grouped according to their origin. The first group is the group of the animals, especially with regard to the head and the body to be studied by comparison of their appearance in the region of the...



258



260

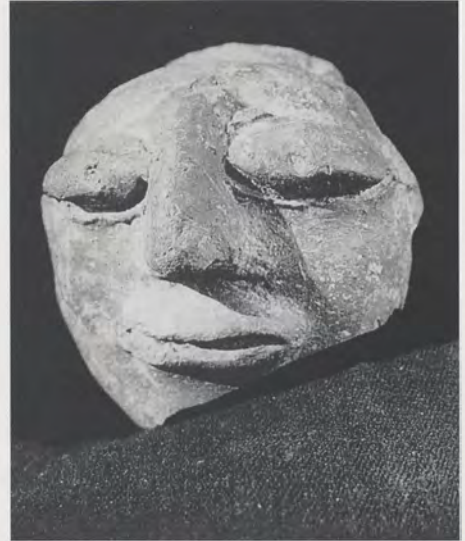

261



262



263a



263b

2. Terracotta Animal Figurines

The excavation yielded 306 animal figurines and fragments of such, of which 166 are going to be described and depicted and another 140 will be allotted to these types. Moreover, not less than 455 irrelevant tiny fragments, (parts of legs, bodies, tails, trunks etc.) mainly of later levels, have been registered. The types of animals among the described and allotted specimens are distributed to the different periods as follows:

Type	I	II	III	IV	V	VI	VII	VIII	Total
Elephant	—	12	22	5	4	2	1	—	46
Horse	—	4	23	4	1	23	3	7*	65
Humped Bull	2	3	12	26	29	17	1	1	91
Crouchant Bull	—	—	—	—	—	4	4	—	8
Monkey	(?)1	—	14	—	—	—	—	—	15
Bird	—	3	11	5	6	—	—	—	25
Dog	—	2	—	—	1	5	—	4	12
Snake	—	1	—	—	3	1	—	—	5
Camel	—	1	5	—	1	—	1	—	8
Buffalo	—	—	—	1	1	1	—	—	3
Deer	—	—	(?)1	—	—	—	—	—	1
Boar	—	—	(?)1	—	—	—	—	—	1
Lion	—	—	—	1	—	2	—	—	3
Ram	—	—	—	—	3	1	—	—	4
Antelope	—	—	—	—	1	—	—	—	1
Goose	—	—	—	—	—	—	—	1	1
Indistinct	—	3	2	2	5	3	—	2	17
Total	3	29	91	44	55	59	10	15	306

*) Plus a great quantity of hollow legs and parts of hollow bodies of horses.

Notwithstanding the arbitrary nature of this list of finds there seems to be no doubt that the elephant was the favourite animal depicted in Period II, the time of the Mauryas and the Śuṅga Cultural Phase, while in the Mitra Period III the horse becomes as frequently modelled as the elephant, followed by an increasing number of humped bulls and birds. Most surprising is the fact that monkeys appear exclusively in this Period III, if we ignore that doubtful lump of clay from Period I. As far as the condition of the fragments allows to say, these monkeys were all three-legged. In the Kṣātrapa and Kuṣāṇa Periods IV and V elephant and horse seem to have gone out of fashion; they are replaced by diverse types of humped bulls. But in the Period VI all of a sudden the horse is "in" again though now depicted differently compared with those of the preceding periods. For the outcome of Periods VII and VIII one has to bear in mind that these late levels were presumably cleared out by the inhabitants before leaving the place.

The animal figurines and fragments have been arranged here according to their stratification. Changes in style and decoration of the animals, especially with regard to elephants and horses, are best to be studied by comparison of their appearance in the succession of periods.

Rough drawings may show the types of humps characterizing the humped bulls.

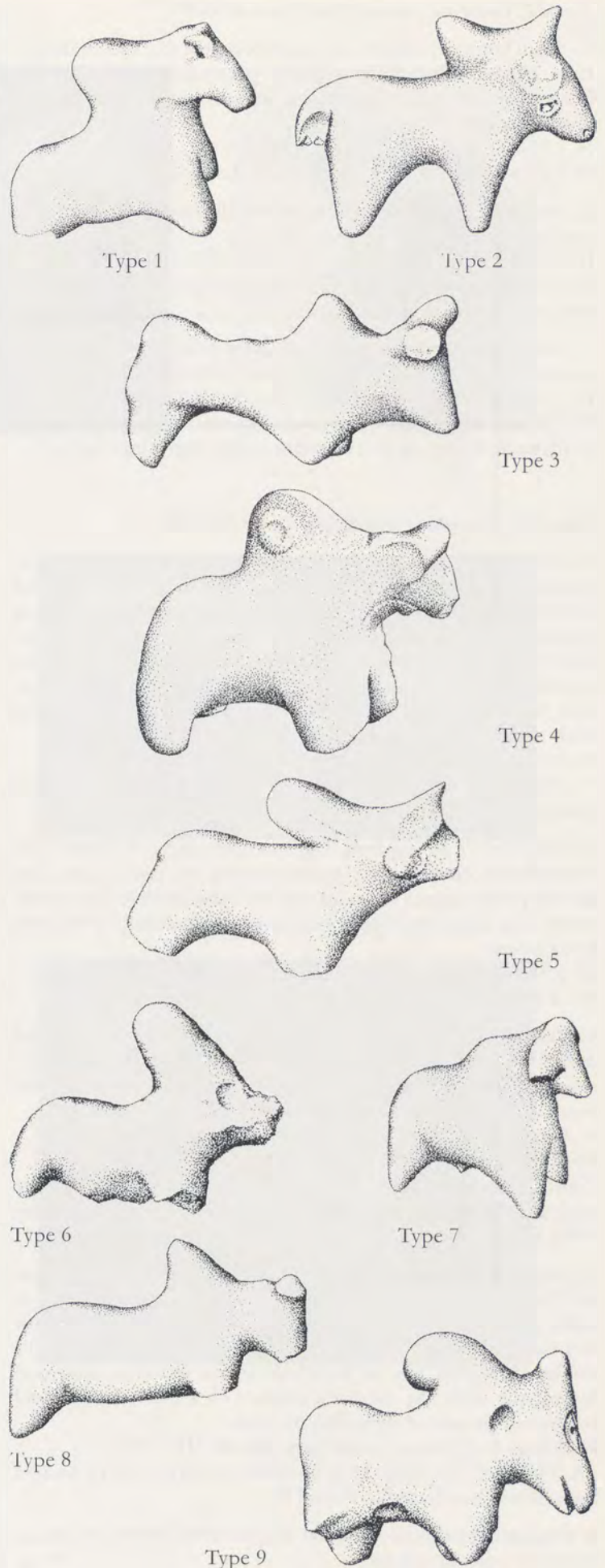

2
Period I. Terracotta Animals from Levels 40 to 37

1. Small lump of unburnt clay resembling the face of a monkey?. Eyes incised semicircularly above protruding jaw. Wrinkles between eyelids and horizontal line on forehead. Possibly the product of chance.

H. 1.7 cm. Colour: grey. No. So I 386.

FS 2 IV 8.7/Be 17.5, H. 15.42 m. PGW-Level 38/37

2. Neck of a bull? Slanting incised lines on neck and around the head-part where horns begin to protrude.

H. 3.9 cm. Colour: yellow-brown. No. So III A 3103.

FS. 2 IV 2.45–6.6/Be 18.0–19.5, H. 16.02–15.90 m. Uppermost level of PGW. L.37

3. Fragment of a bull's head. Left horn broken off. Right one incised with parallel lines. Eyes deep-set with elevated pupil.

H. 7.5 cm. Colour: yellow-brown. No. So III A 2065.

FS. Filling. On the analogy of no. 2 this piece has on the ground of its material, colouring and decoration to be dated into Period I.

Period II. Terracotta Animals from Levels 36 to 29

4. Elephant. Trunk bent downwards to ca 60°. Tusks shown as coming out of their root-sheaths but broken short. Preserved right ear protruding sideways showing an incised line dividing the ear in two halves. Eyes incised as lozenges within which the pupil is pricked. Decoration consists of punctured holes on the forehead and a band each hanging over the ears and ending in tassels. Another band decorated with incised strokes encircles the body of the animal in its back part just before the hind legs.

H. 7.0 cm. L. 14.5 cm. Colour: grey. No. So I 212.

FS. 3 II 3.8/Ca 18.2, H. 11.50 m in a well starting at 15.10 m, i.e. Early Maurya. L.35

5. Fragment of an elephant. Legs and part of trunk broken off. Trunk bent from horizontal position nearly in a right angle. Eyes shown within incised lozenges, the iris being indicated as an elevated ring. Head and upper part of trunk decorated with three lotus rosettes.

H. 6.9 cm. L. 16.1 cm. Grey with black slip. No. So I 377.

FS. 2 IV 0.95/Cc 1.35, H. 16.10 m. Maurya. L.32

6. Fragment of an elephant. Legs, trunk and part of head and neck broken off. Stumps of the tusks protruding from the root-sheaths. Eyes incised as lozenges with a cirlet indicating the pupil. Head and body entirely covered with punched circlets.

H. 9.4 cm. L. 12.9 cm. Grey, black-slipped. No. So III A 3045.

FS. 2 IV 9.7/Cc 15.7, H. 15.98 m. Maurya. L.32

Note: Further specimens of elephants of types no. 5 and 6 are registered as finds nos. So III A 507; 3015; 3045; 3287; 3326; 3364; 3529; 3620.

7. Fragment of an elephant. Trunk, part of head and legs broken off. Eyes shown as lozenges with cirlet for the pupil. Stumps of tusks protruding from their root-sheaths. From the broken off ears hang striped bands with large tassels down to the animal's thighs. A double row of punched circlets stretches aside and behind the neck. At the back remains of a band with incised strokes are preserved encircling the body.

H. 8.1 cm. L. 11.3 cm. Colour: grey. No. So III A 1014.

FS. 3 I 0.5–4.5/Ca 17.0–19.5, H. 22.50–22.20 m. Out of context but safely to be allotted to Period II.

8. Fragment of a humped animal. Head entirely broken off. Short but thick legs, stumpy tail.

H. 6.8 cm. L. 10.5 cm. Colour: red. No. So III A 1958.

FS. 3 I 10.8–11.9/Ca 16.3–17.5, H. 15.00–14.70 m in a well starting at 15.85 m, i.e. Early Maurya. L.34

9. Humped bull. Hind legs broken off. Hump type 1.

H. 6.0 cm. L. 7.9 cm. Colour: grey. No. So III A 3407.

FS. 2 IV 14.8/Cc 7.0, H. 16.50 m. Śuṅga C.P., L.30

Note: Further specimen of humped bull of this type registered as no. So III A 2569.

10. Head of a horse with head-collar. Straps of the collar decorated with punched circlets. Eyes incised as lozenges with pricked pupils. Ears mutilated.

H. 6.1 cm. L. 9.1 cm. Grey, black-slipped. No. So I 201.

FS. 3 II 3.9/Ca 18.6, H. 16.40 m. Maurya. L.33

Note: Further specimen of same type as no. 10 registered under So III A 1288.

11. Mutilated small animal. Calf or horse. Traces of a mane (?) seem to indicate a horse. Transverse hole through the nose is evidently for fastening a string.

H. 3.3 cm. L. 4.1 cm. Colour: brown. No. So III A 1900.

FS. 3 I 9.1/Ca 16.8, H. 16.25 m. Maurya. L.33

12. Fragment of an animal figurine, probably a horse. Pointed skull (or head with hair bulge), longish mouth. Ears missing. Nose pierced for fastening a string.

H. 6.4 cm. Colour: brown. No. So III A 3014.

FS. 2 IV 7.0/Be 18.0, H. 18.60 m. Śuṅga C.P., L.30

13. Dog? Wrinkled forehead rather than grooved horns. Eyes pricked, mouth slightly open. Legs partly broken off.

H. 6.7 cm. L. 10.9 cm. Light brown, traces of red paint.

No. So I 231. FS. 3 I 12.0/Ca 18.5, H. 15.00 m in a well starting at 15.20 m, i.e. Early Maurya. L.34

14. Dog (?). Top of ears, mouth and the front legs broken off. Eyes incised as circles with convex centre. Thin line cut around neck.

H. 7.0 cm. L. 10.5 cm. Light brown. No. So I 19.

FS. Trench 1. 3 II/Ca. E 34. H. 16.10 m. Maurya L.33

15. Head of an animal without ears, horns or any other identification marks. Eyes entirely pierced. A hole also in tip of mouth or beak.

H. 3.5 cm. L. 3.6 cm. Colour: light brown. No. So I 18.

FS. Trench 1. 3 II/Ca. E 35. H. 16.10 m Maurya. L.33

16. Head and shoulder of a bird. Eyes incised as a circle with pricked pupil.

H. 5.8 cm. Colour: brown. No. So III A 3617.

FS. 2 IV 13.1/Cc 4.4, H. 15.60 m. Maurya. L.33

17. Head of an animal with pointed mouth or bill. Eyes pierced. A transverse hole near the tip of mouth for fastening a string.

H. 3.7 cm. Colour: red. No. So III A 1953.

FS. 3 I 11.3/Ca 16.5, H. 15.85 m (on edge of well 2).

Maurya. L.34

18. Head of a bird. Plain with pointed mouth of beak. Perforation for fastening a string. A circular spot indicates that the eyes may have been applied.

H. 5.3 cm. Colour: brown. No. So III A 3478.

FS. 2 IV 15.5–16.9/Cc 4.0–7.9, H. 16.15–16.00 m.

Late Maurya/Early Śuṅga C.P., L.32/31

19. Head and chest of a bird. Bill slightly open. Eyes applied in form of a ring.



1



2



3



4



5



6



7

Terracotta Animal Figurines. Period I (1, 2, 3), Period II (4, 5, 6, 7)

2



8



9



10



11



12



13



14



15



16



17



18



19



20



21



22

H. 4.5 cm. Colour: reddish. No. So III A 1660.

FS. 3 II 1.0/Ca 17.0, H. 16.85–16.60 m. Śuṅga C.P., L.31

20. Fragment of a snake? Tapering body, small pointed head. Eyes applied as discs with circular punch. Long neck shows vertical striations in front.

H. 6.2 cm. Colour: brown. No. So III A 3351.

FS. 2 IV 13.0–18.25/Cc 5.0–6.5, H. 16.90–16.75 m.

Early Mitra. L.29

21. Head and neck of an animal. Mouth slightly open. Eyes applied in shape of a disc.

L. 4.3 cm. Colour: red. No. So III A 1563.

FS. 3 II 2.0–5.0/Ca 17.1–19.5, H. 17.40–17.15 m.

Early Mitra. L.29

22. Fragment of a camel? Head and long neck. Part of eyes and ears broken off.

H. 4.9 cm. Colour: red. No. So III A 1711.

FS. 3 I 6.5–10.0/Ca 14.2–18.8, H. 17.50–17.20 m.

Early Mitra. L.29

Period III. Terracotta Animals from Levels 28 to 24

23. Fragment of head of a decorated elephant. Eyes are formed by convex discs within incised lozenges. Tusks broken off. Ears applied. Preserved part of head-collar shows one horizontal and one vertical band in the shape of adversifolious twigs.

H. 3.7 cm. L. 5.3 cm. Colour: brown. No. So III A 3460.

FS. 2 IV 12.7–13.6/Cc 2.0–4.5, H. 17.35–17.10 m.

Early Mitra. L.28

24. Fragment of head of a decorated elephant. Eyes incised as lozenges, pupils pricked. Right tusk broken off. Head-collar consisting of three horizontal and one vertical moulded band with geometrical pattern. Ears damaged.

H. 4.2 cm. L. 7.0 cm. Red-brown. No. So III A 3277.

FS. 2 IV 14.0–15.5/Cc 3.0–9.0, H. 17.35–17.20 m.

Early Mitra. L.28

Note: One further head of same type registered under So III A 1042.

25. Head of a decorated elephant. Eyes surrounded by incised lozenges. Circular ears. One vertical moulded and decorated band applied on forehead and down to the breakpoint of the trunk.

H. 4.2 cm. L. 7.3 cm. Colour: brown. No. So III A 3276.

FS. 2 IV 14.0/Cc 3.0, H. 17.20 m. Early Mitra. L.28

26. Trunk of elephant.

L. 8.0 cm. Colour: brown. No. So III A 2320.

FS. 3 I 7.0–9.0/Ca 9.4–10.4, H. 18.10–17.85 m.

Mitra. L.27

27. Fragment of mutilated decorated elephant with remains of a rider (mahout). Head defaced. Along the thighs and legs decorative moulded bands.

H. 10.2 cm. L. 9.6 cm. Colour: brown. No. So III A 2278.

FS. 3 I 2.3/Ca 11.6, H. 18.30 m. Mitra. L.27

Note: Further specimens of this type registered as finds nos. So III A 1065; 3000.

28. Mutilated elephant. Head in horizontal position, trunk presumably raised. Large round ears with a moulded rosette as decoration on the head. Traces of two decorated straps encircling the animal's body.

H. 8.7 cm. L. 12.0 cm. Red-brown. No. So III A 3292.

FS. 2 III 19.5–2 IV 0.5/Cc 1.9–9.5, H. 18.15–18.00 m.

Mitra. Ca L.26

Note: Further specimens of the type of no. 28 registered as finds nos. So III A 149; 195; 242; 249; 2075.

29. Undecorated elephant. Trunk and legs broken off. Eyes framed by incised lozenges, pupils pricked. Ears round. Body and head finely shaped.

H. 8.1 cm. L. 11.0 cm. Red-brown. No. So III A 2211.

FS. 3 I 9.0/Ca 14.2, H. 18.10 m. Mitra. L.27

Note: Further specimens of type of no. 29 registered as finds nos. So III A 415; 3060; 3068.

30. Back of an elephant with wagging tail. Traces of an applied decorated band.

H. 10.7 cm. Colour: red. No. So III A 2612.

FS. 2 V 13.0/Ca 6.6, H. 18.10 m. Mitra. L.27

31. Elephant with traces of a rider (mahout). Raised head damaged. Thighs and legs decorated with oblong chains of pinholes.

H. 7.3 cm. L. 9.5 cm. Colour: grey, black slip.

No. So III A 3669. FS. 2 V 8.5/Cc 8.3, H. 18.35 m.

Mitra. L.26. May originate from an earlier level.

32. Mutilated elephant. Legs and trunk broken off. Ears integrated with the upright forehead. Eyes applied. Traces of tusks. Sharp crest running from neck to tail.

H. 8.5 cm. L. 18.1 cm. Colour: red. No. So III A 1955.

FS. 3 I 5.0/Ca 15.8, H. 19.80 m. Late Mitra. L.25

33. Fragment of an elephant's saddle with pinhole decoration.

H. 4.1 cm. L. 3.1 cm. Colour: red-brown. No. So III A 3325.

FS. 2 V 13.0/Cb 14.35, H. 18.90 m. Late Mitra. L.25

34. Head of a horse with head-collar consisting of crosswise applied bands. Small bulgy head-dress on top, small ears, roundish mouth. Eyes incised as a simple slanting stroke.

H. 5.1 cm. L. 5.3 cm. Red-brown. No. So III A 3308.

FS. 2 V 12.8–14.0/Cc 6.7–9.5, H. 17.20–17.05 m.

Early Mitra. L.28

35. Horse with rider. Oversized neck. Head decorated with a head-collar consisting of applied straps in the shape of adversifolious twigs. Same sort of bands in front of right leg and behind the rider. Eyes incised as a slanting stroke. On top an upright bulge of mane. Head of rider broken off, his arms are fastened to the horse's neck.

H. 15.6 cm. L. 11.8 cm. Light brown. No. So I 320.

FS. 2 IV 3.3/Be 18.0, H. 19.80 m. Mitra. L.27

36. Head of horse. Decorated with head-collar of crossing adversifolious twig-bands. A large disc covers one of the cross-points. Small ears. Upright bulge of hair on top.

H. 8.2 cm. Colour: brown. No. So III A 3306.

FS. 2 IV 18.0/Cc 7.5, H. 17.20 m. Early Mitra. L.28

37. Horse with head-collar like no.35. Adversifolious twigs around neck and on back. Small ears, eyes framed by lozenges. Originally perhaps with rider, now missing.

H. 13.5 cm. L. 12.0 cm. Light brown. No. So I 246.

FS. 3 I 6.0/Ca 16.7, H. 17.90 m. Mitra. L.27

Note: Further specimens of horses of the type of nos. 35 and 37 are registered as finds nos. So III A 25; 298; 1452; 2241; 2246; 2581; 2721; 3043; 3044; 3100; 3275; 3282; 3290; 3331.

38. Mutilated horse with arched and crested neck. Eyes in lozenges. Traces of decorative bands only.

H. 9.4 cm. L. 11.9 cm. Colour: brown. No. So III A 3408.

FS. 2 V 17.0/Cb 16.9, H. 18.25 m. Mitra. L.27

Note: One more specimen of same type registered under So III A 2067.

39. Head of a horse without head-collar. Eyes in lozenges, extremely small ears. Finely modelled.

H. 2.3cm. L. 6.4cm. Light brown. No. So III A 2891.

FS. 2 IV 10.45/Be 19.0, H. 20.40m. Mitra. L.26

40. Head of a horse with head-collar and hair bulge between ears. Applied bands of collar plain with patchy ends. Eyes shaped as lozenges with prick. Pierced nostrils.

H. 7.4cm. L. 8.0cm. Colour: light brown. No. So I 274.

FS. 2 V 10.9/Ca 15.0, H. 19.30m. Late Mitra. L.25

41. Crested horse. Small ears. Eyes applied. Mouth slightly open.

H. 6.2cm. L. 8.0cm. Colour: red. No. So I 374.

FS. 2 V 13.5/Cc 5.0, H. 18.88–18.65m. Late Mitra. L.25

42. Mutilated humped bull. Part of mouth, horns and legs broken off. Eyes in incised lozenges. Horns showing parallel striation. Hump type 2.

H. 7.4cm. L. 10.4cm. Colour: brown. No. So III A 3273.

FS. 2 IV 13.6/Cc 3.3, H. 17.32m. Early Mitra. L.28

43. Humped bull. Left horn broken off. Eyes in lozenges. Tip of mouth pierced. Hump type 2; protruding straight from the neck.

H. 4.2cm. L. 5.6cm. Colour: grey. No. So III A 3438.

FS. 2 IV 5.0/Cc 0.5, H. 17.90–17.70m. Mitra. L.27

44. Humped bull. Hump type 3.

H. 7.5cm. L. 9.0cm. Colour: dirty. No. So III 1982.

FS. 3 I 8.3/Ca 11.8, H. 19.10m. Mitra. L.26

45. Small humped bull. Hump type 4.

H. 2.8cm. L. 3.5cm. Colour: brown. No. So III A 2474.

FS. 2 V 14.2/Ca 3.6, H. 19.15m. Mitra. L.26/25

Note: Further specimens of this conspicuously small type of bull in Mitra levels are registered as find nos. So III A 1980; 2196; 2197; 2204; 2774.

46. Humped bull with damaged head. Hump type 5.

H. 4.6cm. L. 7.6cm. Colour: red. No. So III A 3319.

FS. 2 V 2.5–5.0/Cb 9.5–12.5, H. 18.70–18.50m.

Late Mitra. L.25

47. Humped bull with slightly opened mouth. Hump type 1.

H. 5.4cm. L. 6.7cm. Blackened. No. So III A 1751.

FS. 3 I 1.6/Ca 8.8, H. 19.80m. Late Mitra. L.25

48. Crouching cow with splintering neck.

H. 7.8cm. L. 8.7cm. Colour: brown. No. So III A 2422.

FS. 2 V 15.0/Ca 16.1, H. 19.30m. Late Mitra. L.25

49. Three-legged monkey. Free-standing hand-made body and moulded face. Legs and arms partly broken off. A stiff tail serves as third leg. Face of unusual type: Eyes and nose form a deep-set triangle below narrow forehead. Eyes shaped as single circles, nose with large nostrils. Ears shown as two concentric rings. Three incised strands of hair cover the cheeks. The hair on the head is indicated by rows of punched holes. The back of the head is unmodelled and flat.

H. 10.5cm. Colour: red. No. So I 322.

FS. 2 V 7.0/Ca 6.1, H. 18.42m. Mitra. L.27

50. Three-legged monkey with hand-made body and moulded face. Left arm stretched sideways, right one broken off. From left shoulder to right hip runs an *upavīta*-like ribbon. Similar plain ribbon is applied as a girdle. Legs broken away from thighs. Moulded face differs from that of no. 49. The rather large eyes

consist of two concentric rings each. Two strokes are slantingly incised in the cheeks, indicating hair of the beard (cp. nos. 49; 53 ff.). The hair on the head is laid in parallel vertical strands. The back of the head is unmodelled and flat.

H. 10.0cm. Colour: red. No. So I 326.

FS. 2 V 10.3/Ca 14.5, H. 18.35m. Mitra. L.27

51. Three-legged monkey. Body hand-made, face moulded. Right arm broken off. Extremely long left arm reaching downward touching the genitals with the hand. Third leg on the flat back partly broken away. The moulded face is worn, eyes and hair seem to be similar to no. 50, but the lower jaw is put forward.

H. 13.3cm. Colour: brown. No. So I 368.

FS. 3 I 0.2/Cb 1.4, H. 18.00m. Mitra. L.27

52. Head of a monkey. Well-cut face with lower jaw sticking out. Low forehead, large eyes shown as elevated lids and eyeballs. Triangular nose with marked nostrils. Three strands of hair cover the cheeks like creases. Flat thick lips. Hair worn, originally arranged in vertical strands. Clay mixed with mica.

H. 4.5cm. D.3.7cm. Red with mica. No. So I 281.

FS. 2 V 12.7/Ca 4.5, H. 18.46m. Mitra. L.27/26

53. Three-legged monkey with moulded face. Arms and legs (incl. third leg) broken off. Face of a third variety: Jaws sticking out, mouth slightly open showing a row of teeth. Three strands of hair are running slantingly from the eyes to the lower jaw. The eyes are given as elevated rings with hole. Hair is upturned. Circular ears applied to the sides of the head. Back flat.

H. 9.1cm. Colour: brown. No. So I 310.

FS. 2 IV 3.9/Be 15.2, H. 20.00m. Mitra. L.27/26

54. Mutilated moulded head of a monkey with a tenon for insertion into the hand-made body. Eyes shaped as circles with central pellet. Right eye shows distinct rays radiating like eyelashes from the circle up to the double-lined brow. Between the eyebrows a hole is marked. Three nearly vertical strands of hair cover the cheeks. Jaws are sticking out, mouth is damaged. Above and along the narrow forehead rows of punched holes indicate hair.

H. 4.8cm. Colour: brown. No. So I 312.

FS. 2 V 6.5/Ca 3.5, H. 18.80m. Mitra. L.26

55. Moulded head of a monkey. Eyes in shape of two concentric circles embedded in the cavity above the sticking out jaws. Three strands of hair covering the cheeks. Traces of a row of teeth in the mouth. Head-hair upturned in parallel locks.

H. 3.2cm. Colour: brown. No. So I 321.

FS. 2 V 7.5/Ca 6.5, H. 18.60m. Mitra. L.26

Note: Further specimens of similar type of monkey heads registered as finds nos. So III A 1689; 3094; 3538; 3557; 3573; 3634.

56. Mould of a monkey's head. Eyes shaped as a ring with central pellet. Eyebrows dotted. Hair upturned. Two or three strands of hair on cheeks. Mouth slightly open, showing row of teeth.

H. 5.0cm. Colour: brownish. No. So III A 531.

FS. Surface find. Out of context.

57. Head and neck of a parrot. Plain bulgy ring around beak. Eyes applied in shape of discs. Tuft of hair on top. Perforation behind beak-ring for fastening a string. Further plain ring around neck.

H. 5.2cm. Colour: red. No. So III A 2358.

FS. 3 I 8.5/Ca 12.1, H. 17.85m. Early Mitra. L.28

58. Bird with long-drawn body pierced for a wheel-axle. Pointed beak, crested head. Perforation through head, perhaps marking eyes and serving for fastening a string.

- H. 5.5cm. L. 7.8cm. Colour: brown. No. So III A 3230.
FS. 2 V 17.5/Cb 0.8, H. 18.05m. Mitra. L.27
Note: More fragments of this type of toybird from Mitra levels registered as find nos. So III A 2974; 3113; 3283; 3338; 3441.
59. Fragment of a toybird pierced for wheel-axle. Short rounded beak and tufted head. Perforation for fastening a string, perhaps indicating eyes also.
H. 4.5cm. L. 9.2cm. Colour: brown. No. So III A 3334.
FS. 2 IV 11.4–12.85/Cc 5.0–9.5, H. 17.70–17.55m.
Mitra. L.27
Note: One more specimen of toybird of same type as no. 59 registered as So III A 2972.
60. Mutilated head of bird with pointed beak. Perforation for fastening a string.
H. 3.3cm. Colour: brown. No. So III A 3296.
FS. 2 IV 15.5–17.0/Cc 0.5–9.5, H. 17.50–17.35m.
Early Mitra. L.28/27
61. Head of a bird with crested head. Eyes perforated.
H. 3.2cm. Colour: grey. No. So III A 3166.
FS. 2 V 4.03/Cb 8.19, H. 17.70m. Mitra. L.27
62. Head of an animal. Lower jaw (?) broken off. Eyes applied in shape of flat discs.
H. 2.8cm. Colour: brown. No. So III A 3677.
FS. 2 V 6.9–10.7/Cb 14.0–16.5, H. 18.00–17.95m.
Mitra. L.27
63. Head of an animal with perforation for the eyes. Applied ears. Small hole in tip of mouth.
H. 4.3cm. Colour: brown. No. So III A 2988.
FS. 2 IV 4.5/Be 19.0, H. 19.35m. Early Mitra. L.28
64. Fragment of two-humped camel. Mouth and left hind leg broken off.
H. 12.4cm. Colour: red. No. So III A 2373.
FS. 3 I 1.4/Cb 4.5, H. 18.35m. Mitra. L.27/26
Note: One more specimen of two-humped camel registered under So III A 3670 (L.26)
65. Uplifted head of a camel with slightly opened mouth. Pierced eyes framed by a lozenge.
H. 3.0cm. Colour: brown. No. So III A 2953.
FS. 2 IV 7.7–10.2/Be 16.4–19.0, H. 19.52–19.40m.
Early Mitra. L.28/27
66. Head of an animal (camel?). Plain neck and head with small slits as eyes and applied small discs as ears. Mouth slightly open.
H. 2.7cm. L. 3.5cm. Colour: red. No. So III A 3663.
FS. 2 III 13.0–17.1/Cc 6.65–8.15, H. 18.63–18.50m.
Mitra. L.26
67. Fragment of a camel. Head and legs missing. Between hump and tail a bulgy band covering the rear part.
H. 3.7cm. L. 6.6cm. Colour: brown. No. So III A 2604.
FS. 2 V 14.0–3 I 0.5/Ca 16.8–18.0, H. 18.90–18.65m.
Mitra. L.26
68. Mutilated animal (deer?). Legs broken off. Uprturned horns (?), elevated eyes.
H. 4.4cm. L. 5.7cm. Grey. No. So III A 3654.
FS. 3 I 1.5–1.9/Cb 18.5–19.4, H. 18.10–17.95m.
Mitra. L.27
69. Boar (?) with prominent head and short legs. Eyes punched as holes, nostril and mouth marked in tip of muzzle. Ears broken off.

- H. 5.9cm. L. 9.0cm. Colour: red. No. So III A 3234.
FS. 2 III 18.5–19.5/Cc 0.5–9.1, H. 18.90–18.60m.
From Level 26, but found on the edge of a ditch, therefore a slightly later origin possible.



23



24



25



26



27



28



29



30

2



31



32



33



34



36



35

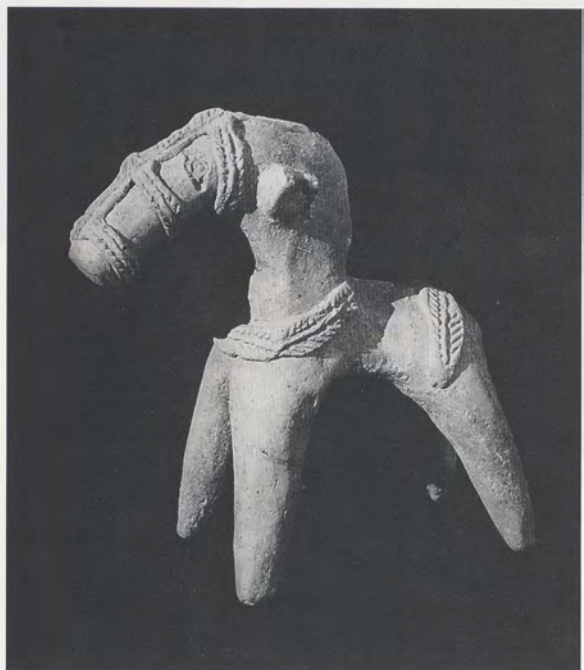

37



38



39



40



41



42



43

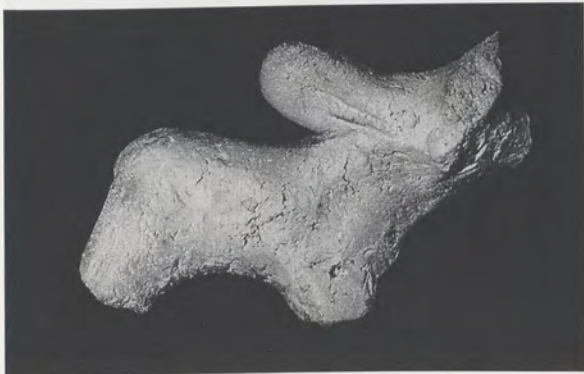

46



45



44



47



48



49



50



51

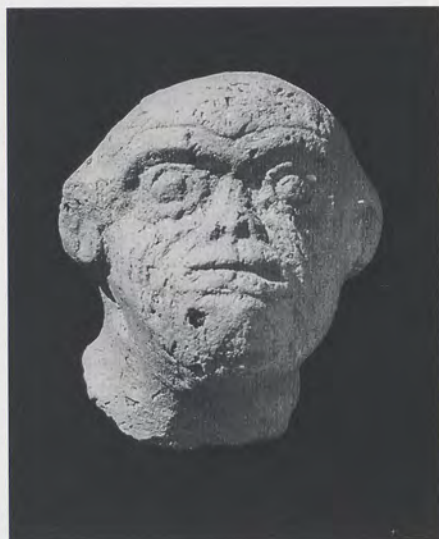

52



53



54



55



56



57



58



59



60



61

2



62



63



64



65



66



67



68



69

Period IV. Terracotta Animals from Levels 24 to 22

70. Fragment of an elephant. Mouth, trunk, tusks and legs broken off. Eyes lenticular with central pellet. Body plain.

H. 6.9cm. L. 11.5cm. Colour: brown. No. So III A 2662.

FS. 2 V 3.0/Ca 0.5, H. 19.90m. Kṣatrapa. L.24

Note: One more specimen registered as find no. So III A 2720.

71. Elephant. Trunk and head-bulges missing. Tusks broken off in their root-sheaths. Eyes punched as small holes with thrown up edges.

H. 4.7cm. L. 7.2cm. Colour: brown. No. So III A 3040.

FS. 2 IV 18.3/Ca 7.0, H. 20.90m. Kṣatrapa. L.23

72. Fragment of an elephant. Part of head and back. Bulgy skull. Traces of tusks. Eyes on lozenges within incised ellipse. Vertical row of punched holes from forehead to the fracture point of the trunk. Two such shallow holes above both eyes also.

H. 5.3cm. L. 9.4cm. Colour: red. No. So III A 2311.

FS. 2 V 1.2/Ca 6.0, H. 20.50m. Kṣatrapa. L.23

73. Headless fragment of an animal (elephant?). Body heavily stamped with an early Kuṣāṇa decorative pattern as found on the pottery often.

H. 7.0cm. L. 8.6cm. Colour: red. No. So III A 3251.

FS. 2 IV 10.95–16.8/Ca 6.4–8.3, H. 20.60–20.35m.

Kṣatrapa. L.23

74. Decorated horse with oversized neck. Applied head-collar consisting of differently patterned bands arranged crosswise, not in the parallel fashion of Mitra horses. Pointed tuft on top of head. Eyes given as punctured discs. Ears applied. One adversifolious band standing up on rear part.

H. 16.1cm. L. 13.3cm. Brown. No. So III A 3548.

FS. 2 III 16.8/Cc 8.9, H. 19.70m.

Kṣatrapa/Early Kuṣāṇa. L.23/22

75. Headless horse decorated with one rosette each applied to the thighs of the four legs.

H. 10.5cm. L. 8.7cm. Brown. No. So III A 3398.

FS. 2 III 17.7/Cc 9.2, H. 19.70m.

Kṣatrapa/Early Kuṣāṇa. L.23/22

76. Moulded figure of a horse. Made by use of two moulds. Details worn. Area between legs closed by a thin layer of clay.

H. 7.7cm. L. 6.8cm. Grey, white paint. No. So III A 2017.

FS. 3 I 0.1/Ca 9.5, H. 20.70m. Kṣatrapa. L.23

77. Fragment of a small horse with arched neck and crest. Head damaged.

H. 4.8cm. L. 3.6cm. Colour: red. No. So III A 1118.

FS. 3 II 5.0–9.5/Ca 16.0–17.7, H. 20.68–20.28m.

Early Kuṣāṇa. L.22

78. Humped bull with damaged head. Hump type 6.

H. 4.0cm. L. 4.7cm. Colour: brown. No. So III A 1906.

FS. 3 I 0.5–6.5/Ca 16.7–18.0, H. 20.15–19.75m.

Early Kṣatrapa. L.(25)/24.

Note: Two more specimens of same type registered under So III A 2815; 3141.

79. Small humped bull. Neck perforated for fastening a string. Hump type 1.

H. 4.0cm. L. 5.1cm. Blackened. No. So III A 2971.

FS. 2 V 6.0–10.5/Cb 13.3–14.5, H. 19.35–19.25m.

Kṣatrapa. L.24.

Note: Five more specimens registered under So III A 2106; 2170; 2535; 2619; 2852.

80. Small humped bull. Hump type 7.

H. 3.5cm. L. 3.75cm. Colour: red. No. So III A 1624.

FS. 3 I 7.5–9.4/Ca 7.0–10.0, H. 20.60–20.30m.

Kṣatrapa. L.23

81. Humped bull. Hump type 2.

H. 6.8cm. L. 6.6cm. Colour: brown. No. So III A 2873.

FS. 2 V 12.3/Cb 3.7, H. 19.25m. Early Kṣatrapa. L.24.

Note: Four more specimens registered as So III A 1901; 2199; 2491; 3458.

82. Small humped bull. Muzzle broken off. Perforation through neck for fastening a string. Hump type 3.

H. 4.1cm. L. 5.7cm. Colour: brown. No. So III A 2826.

FS. 2 V 7.9–9.9/Cb 16.15–18.35, H. 19.90–19.70m.

Kṣatrapa. L.23.

Note: Five more specimens of this type registered as find nos. So III A 2258; 2265; 2556; 2880; 3415.

83. Humped bull. Long stretched body. Hump type 3.

H. 3.7cm. L. 6.6cm. Light brown. No. So III A 2702.

FS. 2 V 0.5–10.5/Ca 9.5–10.5, H. 20.17–19.78m.

Kṣatrapa. L.24/23

84. Humped bull. Hump type 8.

H. 4.4cm. L. 6.4cm. Grey-brown. No. So III A 3631.

FS. 2 V 9.5–10.5/Cb 19.5–Cc 9.5, H. 19.20–18.95m.

Early Kṣatrapa. L.24

Note: Three more specimens of same type registered as find nos. So III A 1709; 2146; 3186.

85. Mutilated buffalo. Long stretched body. Perforation through neck for fastening a string. Muzzle broken away.

H. 3.6cm. L. 7.9cm. Colour: brown. No. So III A 3136.

FS. 2 IV 10.55/Cc 5.7, H. 19.45m. Kṣatrapa. L.23

86. Toybird with perforation for wheel-axle.

H. 6.3cm. L. 8.5cm. Colour: brown. No. So III A 2213.

FS. 2 V 13.7/Ca 17.5, H. 19.70m. Kṣatrapa. L.24

87. Bird with outstretched wings. From a votive tank.

H. 2.8cm. L. 5.1cm. Colour: brown. No. So III A 3178.

FS. 2 IV 14.0/Cc 4.5, H. 18.90m. Kṣatrapa. L.24

88. Head of a bird. Tip of beak broken off. Eyes depicted as large shallow holes.

H. 4.4cm. L. 4.4cm. Colour: greyish. No. So III A 2400.

FS. 2 V 6.5/Ca 11.1, H. 19.95m. Kṣatrapa. L.24/23

89. Head of a bird with semicircular crest.

H. 2.4cm. L. 4.3cm. Colour: brown. No. So III A 2832.

FS. 2 V 2.6/Cb 10.5, H. 20.00m. Kṣatrapa. L.23

90. Head and neck of a bird. Beak sticks out of a hood. Intentionally pierced hole on neck.

L. 4.3cm. Colour: greyish. No. So III A 2645.

FS. 2 V 0.5/Cb 4.5, H. 20.02m. Kṣatrapa. L.23

91. Head of indefinite animal. Perforation for eyes, mouth slightly open.

H. 5.0cm. Colour: red. No. So III A 2291.

FS. 2 V 13.1/Ca 3.2, H. 19.90–19.55m.

Kṣatrapa. L.24

92. Unproportioned lion with oversized head and short legs. Eyes and nose applied, mouth notched. In centre of mouth a large round hole. Hair on forehead and neck incised as strokes.

H. 10.6cm. L. 8.3cm. Colour: grey-brown. No. So I 294.

FS. 2 V 9.7/Ca 13.5, H. 19.65m. Kṣatrapa. L.24

2



70

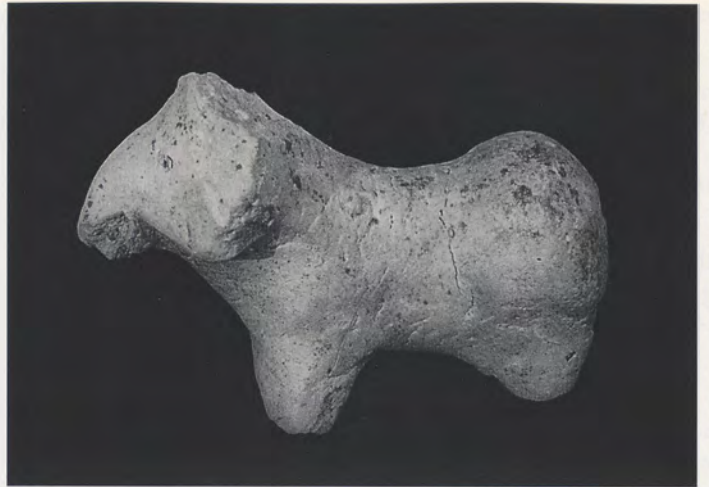

71



72

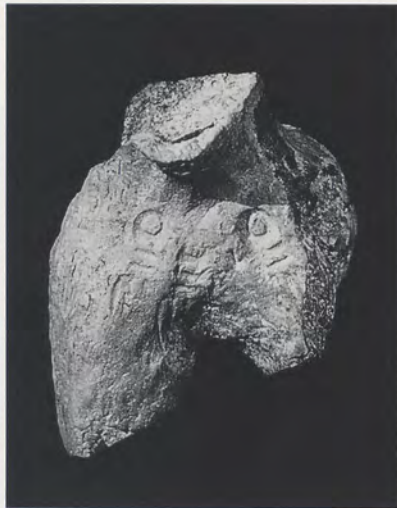

73



74



75



76



77



78

79

80



81

82

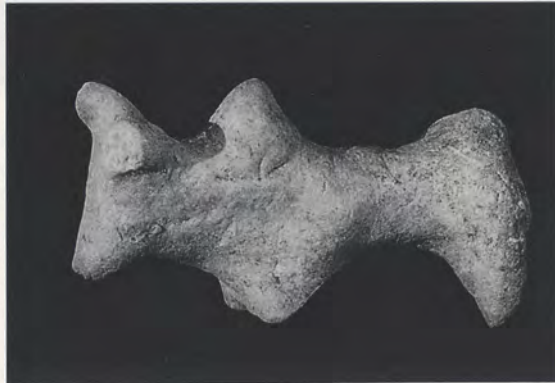

83

84



85



86

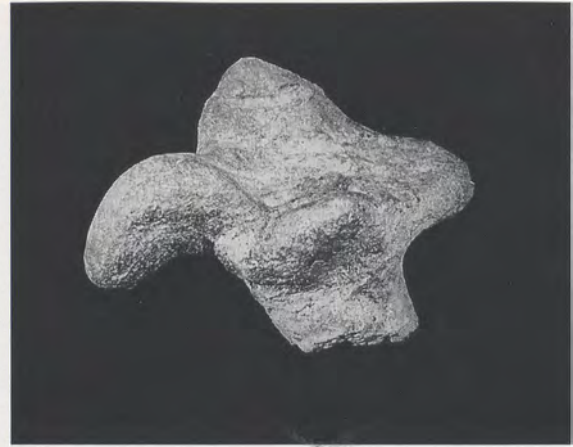

87



88



89



90



91

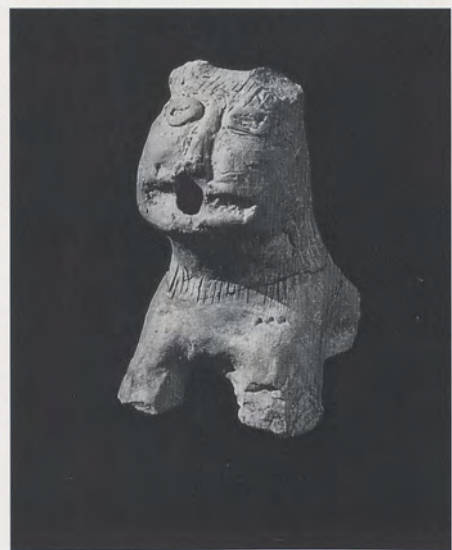

92

Period V. Terracotta Animals from Levels 22 to 15

93. Frontal part of elephant with complete trunk. Eyes inserted as holes. Bulges on head standing upright, being perforated in the centre. Ears stretched sideways. Root-sheath of tusks worn. H. 9.4cm. Colour: dirty brown. No. So III A 1250. FS. 2 V 16.0–19.5/Ca 13.25–19.5, H. 22.05–21.75m. Kuşāṇa. L.20

94. Trunk of an elephant with curved tip. H. 9.3cm. Colour: red. No. So III A 1132. FS. 3 II 4.9–9.5/Ca 18.0–19.5, H. 21.28–20.78m. Kuşāṇa. L.21

95. Rear part of an elephant with elaborated tassel. H. 5.7cm. L. 5.7cm. Colour: brown. No. So III A 1873. FS. 2 IV 4.2–6.2/Cb 16.6–19.5, H. 21.30–21.00m. Kuşāṇa. L.21

96. Fragment of an elephant. Bulgy part of head raised like a hood with perforation in its centre. Eyes seemingly circular with pellet. Root-sheaths of tusks worn. Trunk broken off halfway. On back markings of a saddle.

H. 7.3cm. L. 12.0cm. Colour: red, blackened by fire. No. So III A 2070. FS. 2 IV 7.0/Ca 9.55, H. 22.85m. Kuşāṇa. L.18

97. Head of a horse with arched neck. Short ears, eyes applied as discs. Mouth slightly open. H. 4.0cm. L. 5.6cm. Colour: red. No. So III A 1030. FS. 3 II 6.0–9.5/Ca 14.5–19.5, H. 21.48–21.18m. Kuşāṇa. L.21

98. Large buffalo. Two legs missing. Prominent hump. Eyes punched as circles, mouth slightly open. Ribbon around neck. H. 16.0cm. L. 18.5cm. Colour: red. No. So I 303. FS. 2 IV 5.85/Cb 4.8, H. 21.50m. Kuşāṇa. L.21

99. Small humped bull of unburnt clay. Small head, massive body. Hump with fracture. Hump type 5. H. 4.2cm. L. 5.4cm. Colour: grey. No. So III A 3145. FS. 2 IV 9.5–10.5/Cb 2.0–9.5, H. 21.55–21.40m. Kuşāṇa. L.21

100. Small humped bull with pierced eyes and perforations through neck and hump. Hump type 1. L. 4.3cm. Brown, traces of pūjā paint. No. So III A 1476. FS. 2 III 16.25–19.5/Ca 14.3–16.0, H. 22.30–22.00m. Kuşāṇa. L.20

101. Humped bull with perforation for wheel axles instead of legs. Curved hump of type 2. H. 4.2cm. L. 7.65cm. Dark grey. No. So III A 1387. FS. 2 IV 0.5–6.0/Cb 15.5–17.0, H. 21.55–21.30m. Kuşāṇa. L.21

102. Humped bull. Head broken off. Hump type 6. H. 6.0cm. L. 7.5cm. Colour: brown. No. So III A 958. FS. 2 V 12.0–12.5/Ca 10.5–14.5, H. 22.60–22.30m. Kuşāṇa. L.18

Note: Ten more specimens of this type registered as find nos. So III A 846; 894; 1293; 1393; 1831; 1850; 2539; 2727; 2784; 2879.

103. Humped bull. Perforation for eyes. Hump type 6. H. 4.0cm. L. 5.0cm. Yellow-brown. No. So III A 835. FS. 2 V 10.5–15.0/Cc 0.5–3.5, H. 23.20–22.80m. Late Kuşāṇa. L.16.

Note: One more specimen registered as find no. So III A 1808.

104. Humped bull. Small perforation through mouth, a larger one through neck. Hump type 3.

H. 3.5cm. L. 6.1cm. Colour: brown. No. So III A 3265. FS. 2 IV 9.5–10.5/Be 19.5–Ca 0.5, H. 21.65–21.30m. Kuşāṇa. L.21

Note: Four more specimens of same hump type registered as nos. So III A 1348; 2800; 2898; 2906.

105. Humped bull. Hump type 4 but perforated. H. 5.5cm. L. 7.5cm. Colour: brown. No. So III A 2087. FS. 2 IV 19.6/Ca 0.8, H. 22.10m. Kuşāṇa. L.20

106. Humped bull. Hump type 1. Legs perforated for insertion of wheel axles.

H. 4.5cm. L. 6.9cm. Colour: grey. No. So III A 3293. FS. 2 III 18.6/Cb 15.5, H. 21.60m. Kuşāṇa. L.21.

Note: One further specimen registered as find no. So III A 1550.

107. Forepart of a humped bull. Hump type 1. H. 5.5cm. L. 4.3cm. Light brown. No. So III A 1160. FS. 2 IV 2.0–9.5/Ca 6.0–9.5, H. 23.11–22.81m. Kuşāṇa. L.18.

Note: Three more specimens of same type registered as finds nos. So III A 970; 2111; 2329.

108. Humped bull. Hump type 7. H. 4.4cm. L. 6.8cm. Blackened by fire. No. So III A 656. FS. 2 III 18.0–2 IV 1.5/Ca 7.5–9.5, H. 24.30–23.90m. Late Kuşāṇa. L.16

109. Fragment of a ram with remains of axle-holes through legs. Head mutilated.

H. 5.0cm. L. 9.2cm. Brown. No. So III A 2159. FS. 7.8/Cb 1.1, H. 21.00m. Kuşāṇa. L.21

110. Head of a ram with licking tongue and large nostrils. Left horn preserved.

L. 6.5cm. Colour: red. No. So III A 1699. FS. 2 V 9.5/Cb 6.0, H. 21.60m. Kuşāṇa. L.20/19

111. Fragment of a ram. H. 8.5cm. L. 10.3cm. Colour: brown. No. So III A 791. FS. 2 IV 12.5/Ca 10.5, H. 23.45–22.90m. Kuşāṇa. L.18/16

112. Fragment of a bird with extended wings. H. 5.6cm. L. 9.2cm. Colour: brown. No. So III A 3243. FS. 2 IV 10.0/Ca 11.8, H. 21.40m. Kuşāṇa. L.21

113. Beak of a bird (Garuḍa?). Large lozenge-shaped eye on bulgy part of head.

H. 3.1cm. L. 5.3cm. Colour: red. No. So III A 1361. FS. 2 V 7.5–9.5/Ca 1.0–3.5, H. 21.65–21.35m. Kuşāṇa. L.21

114. Head and neck of an animal (bird?). Eyes indicated by perforation.

H. 5.7cm. Colour: brown. No. So III A 2804. FS. 2 IV 0.5–4.5/Cb 8.0–9.5, H. 21.65–21.30m. Kuşāṇa. L.21

115. Headless bird with incised feathers all over the body. H. 5.8cm. L. 9.6cm. Colour: brown. No. So III A 3183. FS. 2 III 8.0/Cc 0.9, H. 21.20m. Kuşāṇa. L.21

116. Head of a bird. Eyes shaped as incised rings with dotted eyeballs. Beak broken off.

H. 4.6cm. Colour: red with mica. No. So III A 1480. FS. 2 IV 10.5–15.0/Cc 9.5–10.1, H. 22.66–22.06m. Kuşāṇa. L.17

117. Head and neck of a bird. Eyes simply incised as uneven circles. Mouth slightly open.
H. 6.5 cm. Colour: red. No. So III A 1090.
FS. 2 V 19.05/Ca 19.3, H. 23.20 m. Late Kuṣāṇa. L.16
118. Spirally contracted object (snake?). Head broken off.
Ø 3.5 cm. Colour: red. No. So III A 3157.
FS. 2 IV 12.6/Cc 9.35, H. 20.95 m. Kuṣāṇa. L.22/21
119. Hood of an originally seven-headed cobra. Mutilated remains of four heads visible. On the reverse vertically incised lines indicating seven snake bodies.
H. 13.8 cm. B.16.6 cm. Colour: red. No. So III A 1276.
FS. 2 IV 7.2–9.5/Ca 11.0–16.0, H. 22.70–22.50 m.
Kuṣāṇa. L.19
Note: One more specimen of hood-fragment registered as So III A 1286.
120. Head of an animal (antelope?). Horns broken off. Eyes pierced, showing upturned edges.
H. 2.7 cm. Colour: grey-brown. No. So III A 3118.
FS. 2 IV 0.5–6.0/Ca 19.5-Cb 0.5, H. 21.90–21.70 m.
Kuṣāṇa. L.21
121. Head of an animal (camel?). Eyes marked as perforation. Ears applied as patches. Long neck slightly bent.
H. 5.7 cm. Colour: red. No. So III A 1115.
FS. 2 IV 4.5–7.0/Be 16.0–19.5, H. 22.60–22.30 m.
Kuṣāṇa. Ca L.20
122. Small indefinite animal with long-stretched, but worn head and pointed mouth. Ears upright. On back two holes.
H. 2.5 cm. L. 4.1 cm. Blackened by fire. No. So III A 959.
FS. 2 V 12.95/Cb 3.26, H. 22.57 m. Kuṣāṇa. L.18
123. Fragment of an indefinite animal (horse?).
H. 3.3 cm. L. 5.6 cm. Colour: red. No. So III A 1629.
FS. 2 III 11.0/Cb 16.5, H. 22.80–22.50 m. Kuṣāṇa. L.18/17
124. Head and neck of an indefinite animal. Eyes and ears impressed.
H. 5.9 cm. Colour: red. No. So III A 945.
FS. 2 V 2.5–7.5/Cc 8.5–10.5, H. 22.60–22.30 m.
Kuṣāṇa. L.17/16
125. Head of a fawn? Eyes in lozenges. Perforation in front part of head for fastening a string. Nostrils and mouth marked.
H. 6.5 cm. Colour: brown. No. So III A 1031.
FS. 2 IV 6.0–8.0/Cb 2.5–9.5, H. 23.53–23.28 m.
Late Kuṣāṇa. L.16
126. Mutilated animal (rat?). Eyes pierced.
H. 3.2 cm. L. 5.5 cm. Blackened by fire. No. So III A 965.
FS. 2 IV 7.5–9.5/Cb 10.5–16.5, H. 23.67–23.27 m.
Late Kuṣāṇa. L.16
127. Cheeky little dog? Head and ears upturned, tail upright. Eyes inserted as perforation.
H. 5.5 cm. L. 5.5 cm. Colour: brown. No. So III A 895.
FS. 2 V 2.5–7.5/Cc 8.0–9.5, H. 23.05–22.75 m.
Late Kuṣāṇa. L.16



93



94



95



96



97



99



98



100



101



102



103

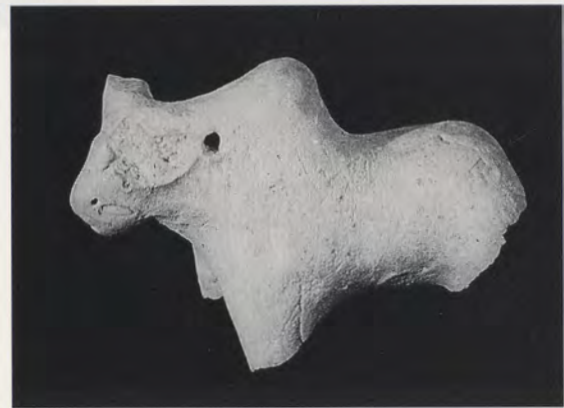

104



105



106



107



108

Terracotta Animal Figurines. Period V



109



110



111



112



113



114



115

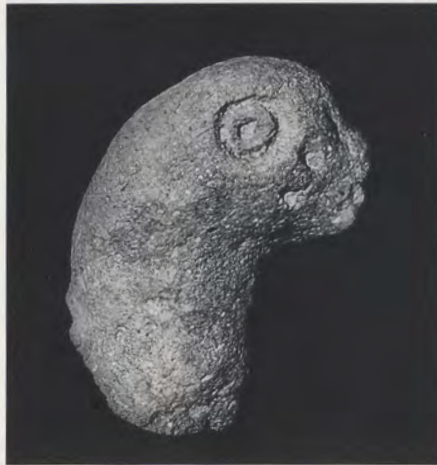

116



117



118



119

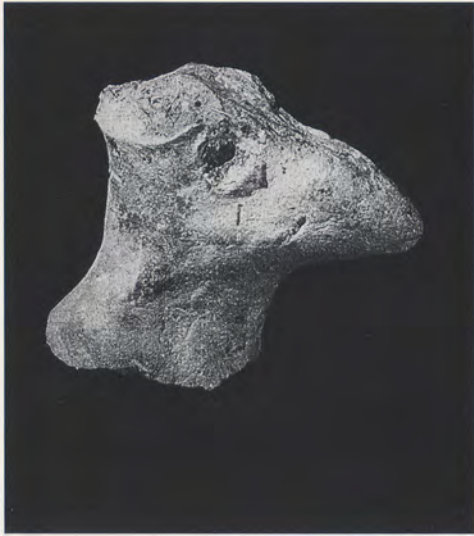

120

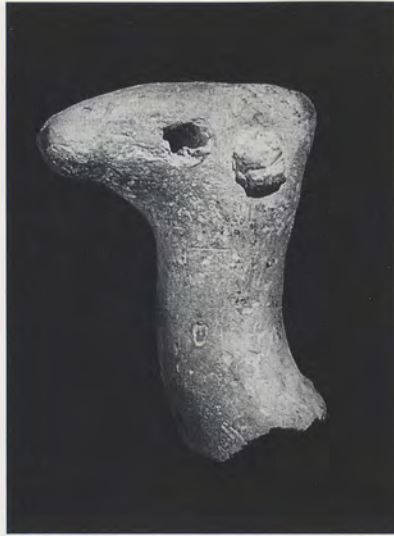

121

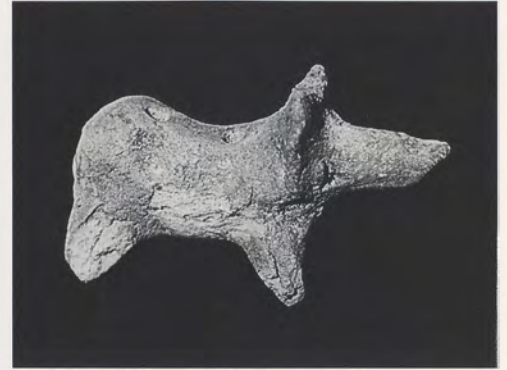

122



124



125

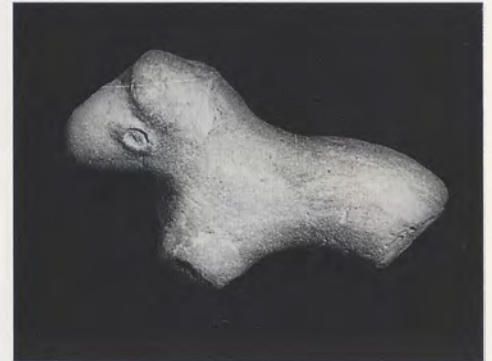

123



126



127

Period VI. Terracotta Animals from Levels 15 to 12

128. Fragment of an elephant with rider (mahout). Trunk and head of rider broken off. Rider's hands stretched out towards the animal's ears. Front legs of the elephant not separately shaped but shown as contracted. Hind legs missing.

H. 6.8cm. L. 8.2cm. Colour: brown. No. So III A 412.

FS. 2 V 8.6/Ca 5.7, H. 24.25m. Gupta. L.15

129. Fragment of an elephant composition moulded at both sides. Elephant obviously in a fighting position with open mouth and raised (but broken off) trunk. Adversary in front of him indistinct.

H. 4.0cm. L. 6.4cm. Colour: brown. No. So III A 561.

FS. 2 III 14.1/Cb 13.25, H. 24.25m. Ca L.15

130. Forepart of a horse. Small head directed downwards. Eyes applied in shape of a broadly rimmed ring. Mane incised as strokes on right side of the neck.

H. 8.7cm. L. 5.6cm. Colour: red. No. So III A 604.

FS. 2 IV 13.0–15.0/Ca 15.5–19.5, H. 24.30–24.00m.

Gupta. L.15

131. Head of same type of horse as no. 130. Mouth slightly opened.

H. 4.0cm. Colour: red. No. So III A 594.

FS. 2 IV 14.5–16.5/Ca 15.0–19.5, H. 24.70–24.00m.

Gupta. L.15/14.

Note: Four more specimens of this type of head registered as nos. So III A 414; 818; 1954; 3611.

132. Head of a horse with proudly arched neck and head. A stamped rosette of holes adorns neck and chest. Mane indicated by a crest. Traces of black painted lines on head and body.

H. 5.9cm. Colour: red. No. So III A 863.

FS.2 V 0.5–1.0/Ca 19.5-Cb 0.5, H. 24.50–24.20m.

Gupta. L.15/14

133. Horse of the head-type of nos. 130–131. The back might have carried a saddle now chipped off.

H. 5.7cm. L. 8.6cm. Colour: red. No. So III A 625.

FS. 2 IV 13.5–15.5/Ca 16.0–19.5, H. 24.20–23.70m.

Gupta. L.15/14.

Note: Three more specimens of this type registered as finds nos. So III A 960; 1322; 2060.

134. Mutilated horse with saddle. Head broken off. Mane incised as strokes on right side of neck. Body of the animal painted with broad black stripes.

H. 8.0cm. L. 11.0cm. Red, black paint. No. So III A 384.

FS. 2 V 17.0–19.0/Ca 10.5–19.5, H. 24.40–24.00m.

Gupta. L.15.

Note: Eight more specimens registered as finds nos. So III A 92; 173; 897; 961; 962; 1226; 1860; 2002.

135. Headless horse with painted, incised and punched decor. Mane shown on right side of neck only as parallel strokes filled with dots inbetween every second pair of lines. Rich patterns of punched holes all over the body.

H. 7.4cm. L. 8.0cm. Red, black paint. No. So III A 433.

FS. 2 V 0.5–2.0/Cb 0.5–4.5, H. 25.00–24.70m.

Late Gupta. L.13

136. Horse with perforation through neck for fastening a string.

H. 7.5cm. L. 10.0cm. Colour: red. No. So III A 892.

FS. 2 III 13.5–19.5/Ca 19.5-Cb 0.5, H. 25.83–25.00m.

Early Medieval. L.12

137. Horse with crested mane. Eyes applied as disc-like patches with incised stroke.

H. 6.4cm. L. 7.7cm. Colour: red. No. So III A 797.

FS. 2 III 19.5/Cb 6.0, H. 25.20–24.80m.

Early Medieval. L.12

138. Humped bull with straight horns. Legs set broadly apart. Eyes applied as small rings with central prick. Nostrils clearly marked, mouth slightly open. Punched pattern of holes between horns. Perforation through mouth for fastening a string. Hump type 2. Traces of painted black stripes.

H. 9.5cm. Red slip with black stripes. No. So III A 272.

FS. 2 IV 14.8–17.5/Be 17.0–20.0, H. 25.50–25.10m.

Gupta. L.15

Note: Twelve more specimens of this type registered as finds nos. So III A 487; 527; 725; 774; 910; 926; 927; 957; 1019; 1029; 1732; 1800.

139. Head of humped bull of the type of no. 138 but with richer decoration by punching holes along the horns and application of a ring between horns.

H. 3.1cm. Colour: red. No. So III A 1935.

FS. Stray find. Out of context.

140. Humped bull with mutilated head. Hump type 6.

H. 3.9cm. L. 4.3cm. Colour: grey. No. So III A 578.

FS. 2 IV 16.5–19.5/Ca 0.5–2.5, H. 24.30–24.00m.

Gupta. L.15.

Note: One more specimen registered as find no. So III A 455.

141. Extremely small humped bull. Hump type 1.

H. 2.0cm. L. 2.0cm. Colour: brown. No. So III A 635.

FS. 2 IV 8.3–9.5/Ca 4.0–9.5, H. 24.20–23.85m.

Gupta. L.15

142. Fragment of a ram. Perforation through head for fastening a string. Incised strokes on neck and right thigh indicating hair.

H. 7.0cm. L. 6.7cm. Colour: brown. No. So III A 1010.

FS.2 IV 11.0/Cb 19.5, H. 23.67–23.37m.

Late Kuṣāṇa/ Late Gupta. L.16–13

143. Fragment of an indefinite object with the depiction of a buffalo with striped horns.

H. 6.3cm. Colour: red. No. So III A 560.

FS. 2 IV 13.6/Ca 9.4, H. 24.00m. Gupta. L.15

144. Head and neck of a swan (?). Beak broken off. Eyes applied as round discs.

H. 8.0cm. Colour: light brown. No. So III A 991.

FS. 2 IV 9.5–10.5/Ca 19.5-Cb 0.5, H. 25.21–24.91m.

Early Medieval. L.12

145. Head and neck of an indefinite animal (fawn?). Ears applied in shape of flat discs, eyes incised as circles, mouth perforated for fastening a string.

H. 5.5cm. Colour: red. No. So III A 582.

FS. 2 III 10.0/Cb 19.0, H. 24.30–24.00m. Ca Gupta. L.15

146. Small dog. Perforated eyes, upright ears and tail.

H. 5.5cm. L. 4.8cm. Colour: brown. No. So III A 1009.

FS. 2 IV 10.5/Cb 9.5, H. 24.81–24.51m.

Late Gupta/ Early Medieval. L.13.

Note: Four more specimens of same type registered as finds nos. So III A 432; 583; 1934; 1937.

147. Fragment of a terracotta relief with the depiction of a Makara with human leg on his back. Already described under HUMAN FIG., no. 186

H. 19.0cm. B.19.0cm. Brick-red. No. So I 127.
FS. 2 V 10.2/Ca 6.15, H. 24.50m. Gupta. L.14

148. Fragment of a cobra-hood. Tip of mouth pierced. Eyes applied as flat discs. Vertically incised lines on the front side of the extended hood.

H. 2.9cm. B.4.6cm. Colour: brown. No. So III A 490.
FS. 2 V 5.0–7.0/Ca 16.5–19.5, H. 24.20–23.90m.
Gupta. L.15

149. Mutilated animal (fox?). Long stretched body and tail. Mouth broken short.

H. 4.2cm. L. 9.7cm. Brick-red. No. So III A 536.
FS. 2 III 19.8/Be 19.95, H. 24.55m. Ca L.14

150. Lion. Flat face showing two semicircles with one applied eye each. Mouth slightly open. Body and three legs broken off.

H. 7.5cm. Colour: brown. No. So III A 243.
FS. 2 IV 5.5–9.5/Be 14.5–17.5, H. 25.80–25.10m.
Late Gupta. Ca L.14

151. Lion similar to no. 150 but with more elaborate face.

H. 5.6cm. Colour: grey. No. So III A 732.
FS. Surface find. Out of context.

152. Small bull crouchant on flat base.

H. 4.1cm. L. 4.0cm. Colour: red. No. So III A 621.
FS. 2 IV 0.5–4.0/Cb 0.5–9.5, H. 24.70m.
Late Gupta/ Early Medieval. L.13.

Note: One more specimen of this type registered as So III A 522.

153. Hollow bull being used as a rattle. Made by two moulds. Sharp pointed horns, slightly opened mouth.

H. 8.2cm. L. 7.5cm. Colour: brown. No. So III A 585.
FS. 2 IV 2.85/Cb 2.77, H. 24.45m. Late Gupta. L.13

Note: One more specimen registered under no. So III A 503.

Period VII. Terracotta Animals from Levels 11 to 8

154. Mutilated moulded bull crouchant on a flat base.

H. 3.3cm. L. 3.4cm. Colour: brown. No. So III A 262.
FS. 2 IV 4.98/Ca 15.2, H. 25.20m. Medieval. L.11

Note: Three more specimens registered as finds nos. So III A 2012; 2013; 2025.

155. Horse with saddle. Head-type as no. 133 but eyes indicated by slits. Mane strokes on right side. Perforation through crest for fastening a string.

H. 6.8cm. L. 8.9cm. Red with mica. No. So I 96.
FS. 2 IV 17.3/Cb 0.5, H. 25.65m. Medieval. L.10

Note: Two more specimens of heads of same type registered as finds nos. So III A 211; 430.

156. Humped bull. Perforation through neck. Hump type 9.

H. 5.0cm. L. 6.0cm. Colour: brown. No. So I 8.
FS. Trench 1. D 10. H. 26.00m. Medieval. Ca L.10

157. Neck and head of an animal (camel?). Ears broken off. Mouth slightly open. Black stripes.

H. 4.2cm. Colour: red, black paint. No. So III A 224.
FS. 2 V 4.6–7.0/Ca 0.5–9.5, H. 25.60–25.20m.

Late Medieval. L.9

158. Mutilated plaque of four-armed Gaṇeśa seated on a flat base. Two hands on stomach, two arms raised.

H. 7.0cm. Colour: brown. No. So III A 1002.
FS. Filling. Out of context.

Period VIII. Terracotta Animals from Levels 7 to 1

159. Fragment of a dog. Ears uplifted, eyes applied in shape of discs with central prick. Perforation through mouth for fastening a string. Necklace of twisted ribbon. Legs broken off.

H. 4.3cm. Colour: red. No. So III A 156.
FS. 2 V 10.5–15.0/Ca 12.0–19.5, H. 26.00–25.50m.

Jat. L.7/6

Note: Two more specimens registered as finds nos. So III A 108; 545.

160. Horse with rider. Hollow and partly wheel-made.

H. 14.1cm. L. 12.7cm. Colour: red. No. So I 102.
FS. 2 IV 19.9/Cc 14.06, H. 25.35m (pit from 6). Jat. L.6

161. Neck and head of a moulded hollow horse.

H. 4.8cm. Colour: red. No. So III A 88.
FS. 2 IV 10.5–14.0/Cb 0.5–9.0, H. 27.75m.

Jat. L.4–2

Note: Five more specimens of same type registered as finds nos. So III A 55; 70; 110; 116; 166.

162. Head of a bull. Moulded and hollow. Right horn broken off.

L. 5.1cm. Colour: red. No. So III A 77.
FS. 2 IV 14.0–19.5/Ca 10.5–19.5, H. 27.50m.

Jat. L.3

163. Neck and head of a goose. Moulded and hollow.

H. 6.5cm. Colour: red. No. So III A 3515.
FS. 2 IV 12.0–15.5/Be 4.5–7.4, H. 26.55–26.25m.

Jat. L.6

164. Fragment of a dog with pointy ears. Eyes inserted as a perforation.

H. 3.9cm. L. 6.3cm. Colour: red. No. So III A 78.
FS. 2 IV 17.0–19.5/Cb 0.5–10.0, H. 28.00m. Jat. L.2

165. Head of an animal with large applied ears and incised strokes. Mouth slightly open.

H. 7.3cm. Colour: grey-brown. No. So III A 2570.
FS. Surface find. Out of context.

166. Fragment of an indefinite animal (horse?). Long mouth, uplifted ears. Two punched circles as decoration (?) on forehead. Eyes pricked. Where legs begin vertical strokes are incised nearly parallel.

H. 7.0cm. Colour: red. No. So III A 198.
FS. Surface find. Out of context.



128



129

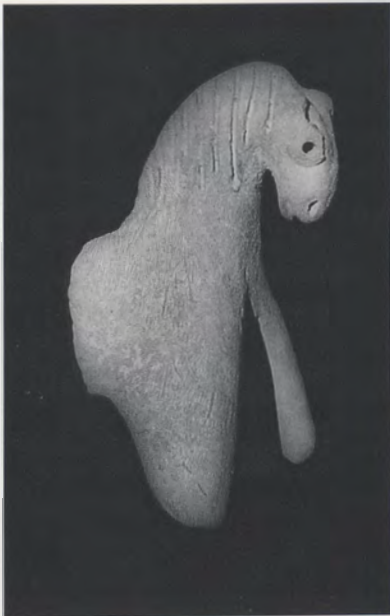

130



131



132



133



134

2



135



136



137



138



139



140



141

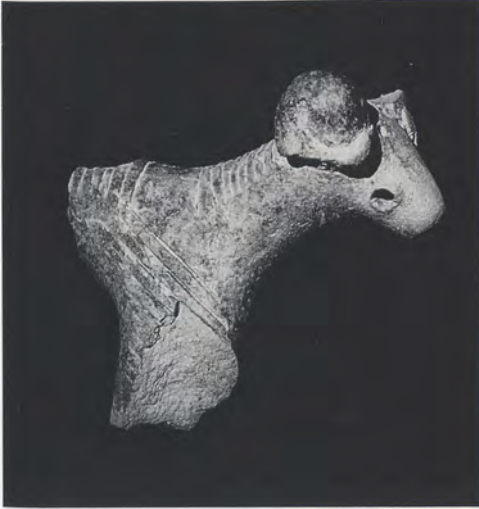

142



143



144



147



145



146

2



148

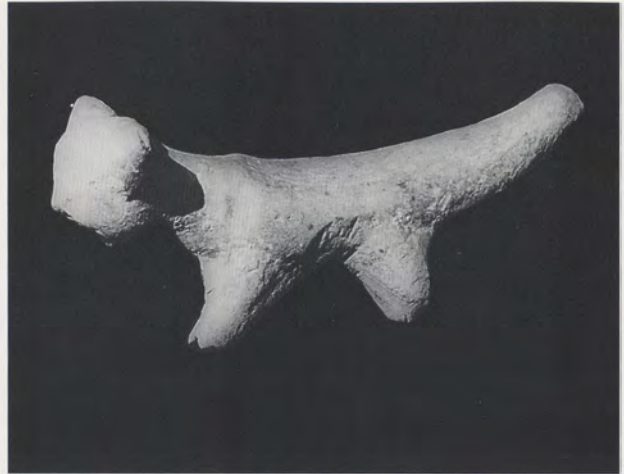

149



150



151



152



153



154



155



156



157



158

2



159



160



161



162



163



164



165



166

3. Miscellaneous Terracotta Objects

Votive Tanks

The excavations at Sonkh yielded altogether 266 fragments of votive tanks. Most of these objects consist of small pieces like parts of the tank wall with lamp or bird on the rim, with a ladder applied to the wall or of fragments of the tank bottom with the depiction of aquatic animals like snake, frog and fish or with remains even of seated human figures. Fortunately, a sufficient number of more complete vessels permits to differentiate between several varieties of votive tanks and to allot most of the fragments to their respective type. A selected group of better preserved tanks and details of such may represent and characterize these types.

The use of votive tanks for performing *pūjā* in the homes of people is not restricted to a short period as often meant. The finds at Sonkh cover the span of time from period II to period VII, i.e. more than a millennium. While a few fragments suggest the starting of votive tank *pūjā* as early as the Mauryas, the end is represented by two tanks of the late type found in level 11, belonging to the medieval period. But the bulk of the finds hails from period III, the time of the Mitras of Mathura in the first century BC which proved to be the most inventive phase for votive tanks.

The main types of votive tanks can be categorized as follows:

A. Round, wheel-made bowl with extended rim and an arbitrary number of lamp-cups applied to it. Inside of bowl just plain (e.g. nos. 1–3).

B. Rectangular or square water-tank with birds and lamps upon the rim and with an integrated building (temple) placed on a platform which is supported by pillars and can be reached by a staircase. A thick stem of lotus stands upright with opened blossom, to swim on the water when the tank was filled. On the ground, figures of snake, frog or fish are applied (e.g. no. 6). Subvariety: Round basin with temple integrated on the ground (no. 12)

C. Single type of a tank with houses built around a court (no. 13).

D. Round vessel with or without lamps upon rim, with a ladder applied to the inner wall and with snake, fish or frog depicted on the ground (e.g. no. 14).

E. Rectangular tank with Mother Goddesses seated along the inner wall carrying a child in their arm and a bowl in their lap (e.g. no. 16). Kṣatrapa/Kuṣāṇa version.

F. Round, wheel-made bowl with four birds on the rim and snake and frog on the ground. No ladder (e.g. no. 22). Kuṣāṇa only.

G. Rectangular tank with a spout, three ladders on the inner wall and a snake applied to the ground (nos. 26). Medieval version.

The majority of fragments from votive tanks found at Sonkh belong, as already mentioned, to a period prior to the Kṣatrapa levels 24/23. All but one of the lamp-and-bird type were intended to be filled with water as is proved by the placing of snake, frog and fish so often on the bottom of the vessel and by a stem of lotus, the open petals of which are meant for lying on the water when the tank is filled. The only exception is type C, a tank with houses arranged in the square but without a human figure in it. Votive tanks equipped with human figures seated along the inner walls in the mostly rectangular vessels firstly appear with the Kṣatrapas. This type has been copied in the Kuṣāṇa period at Sonkh but vanished soon. The water-tank remains the main type of votive tank till the end of finds in the medieval period.

Period II. Votive tanks from Levels 36 to 29

There are seven small fragments of votive tanks, such as lamp-cups, wall-piece with ladder and a bottom piece with applied frog.

All of them seem to come from round vessels. One piece with ladder has been found in a well used in level 34 only. This material points to an early use of votive tanks but does, in our opinion, not yet provide sufficient evidence for a final conclusion. The objects in question are registered as finds nos. So III A 1996; 1978; 3079; 3025; 2724; 2210; 3601.

Period III. Votive tanks from Levels 28 to 24

1. Round, wheel-made vessel with slantingly extended rim on which four lamp-cups are applied. The original number of lamps might have been eight.

Ø 15.8 cm. Colour: brick-red. No. So II 2234.

FS.3 I 6.0/Ca 16.7, H. 17.80 m. Early Mitra. L.28

2. Mutilated round votive tank. Wheel-made. Sharp-edged broadly extended rim on which twelve lamp-cups are preserved.

Ø 28.0 cm. H. 9.2 cm. Colour: brown. No. So III A 3710.

FS. 2 V 10.5–11.7/Cc 4.4–5.0, H. 18.45–18.35 m.

Mitra. L.26

3. Fragment of a votive bowl with extended rim and two lamp-cups.

H. 4.4 cm, L. 10.8 cm. Colour: brown. No. So III A 3064.

FS. 2 V 16.5–17.0/Cb 0.3–2.2, H. 18.75–18.45 m.

Mitra. L.25

Note: Further specimens of comparable rims with lamps registered as finds nos. So III A 1896; 1979; 3035; 3261; 3455; 3707.

4. Fragmentary rectangular votive tank with one lamp-cup preserved on the rim. Spots of fracture prove it to be a tank of type 2 with integrated temple and applied snakes etc on the ground. A whitish mark indicates the water level of the filled vessel. The fracture spots to the left of the lamp are remains of the platform fastened to the wall. The stub on the ground marks the end of the ladder reaching to the platform (cp. no. 6)

25.6 × 27.5 × 9.0 cm. Red-brown. No. So III A 2689.

FS. 2 V 10.5/Ca 15.6, H. 18.36 m. Mitra. L.27

Note: Further specimens of this type registered under So III A 2317; 2893.

5. Fragment of a votive tank with integrated temple on a pillar-supported platform.

27.5 × 27.0 × 9.6 cm. Brown. No. So III A 3081.

FS. 2 V 12.5/Ca 19.5, H. 18.20 m. Mitra. L.27

6. Mutilated votive tank of type B. The now widely damaged rims of the enclosure walls were originally carrying lamps and birds in regular intervals. Aquatic animals like snake, fish and frog are applied to the bottom of the vessel. A strong stalk-like pillar carries a lotus rosette in full bloom, which is to be imagined as floating on water. A platform rests on four thick columns as well as on one side of the wall. A ladder leads down to the ground of the vessel. An oval temple, now roofless, stands on the platform.

This vessel was used for the *pūjā* in a private house. Shaped as a water tank and showing a ladder from the ground to the platform, the belief that here a water-god was worshipped may be justified. It is even possible that this vessel was used for a *Nāga* ritual.

32.0 × 36.0 × 14.5 cm. Dirty brown. No. So I 275.

FS.2 V 2.1/Ca 14.0, H. 19.55 m. Late Mitra. L.25/24

Note: Further fragments of this type of votive tank are registered under nos. So I 247; So III A 2684; 3368.

7. Full-blown lotus on a thick stalk, from the bottom of a votive tank of type 2.

H. 8.7 cm. Colour: dirty grey. No. So III A 2322.
FS. 2 V 16.3/Ca 14.0, H. 19.65 m. Kṣatrapa. L.24
Note: Further lotus stalks of votive tanks of this period registered under So III A 2245; 3028.

8. Temple of a votive tank in the shape of a circular tent with pointed roof. The building rested on two columns one of which is preserved. The rear part was, as indicated by a fracture line on the base, fixed to the wall of the tank. The platform on which the building stands is broken away all around.

H. 14.9 cm. Temple 9.1 cm. Colour: light brown.
No. So I 10. FS. Trench 1, B. 35, H. 18.20 m.
Mitra. L.27

9. Fragment of a votive tank temple in shape of a hut. Platform broken away around the base of the building.

H. 7.5 cm. Colour: red. No. So I 222.
FS. 3 I 4.0–7.3/Ca 13.0–15.5, H. 18.95–18.65 m.
Mitra. L.26

10. Fragment of a small temple from a votive tank. Entrance modelled like a curved arc with three pinnacles. In the lower part the building was decorated with incised horizontal strokes.

H. 14.8 cm. Colour: red-brown. No. So III A 3109.
FS. 2 V 9.5–10.5/Cb 5.2–9.5, H. 19.40–19.22 m.
Kṣatrapa. L.24

11. Triangular temple from a votive tank. Platform missing. Two pinnacles on the ridge of the roof.

H. 5.8 cm. L. 6.2 cm. Colour: red. No. So III A 1975.
FS. 3 I 5.0–7.0/Ca 13.5–17.4, H. 19.60–19.40 m.
Late Mitra. L.25

Note: Two further specimens of this temple type registered under So III A 2250; 2251.

12. Fragmentary votive tank. Round basin with integrated round building (temple). On the ground a snake and a bird (or tortoise?). Upon the partly damaged rim of the enclosure one double-lamp is preserved.

H. 6.3 cm. Ø 27.8 cm. Colour: red. No. So I 323.
FS. 2 V 9.6/Ca 2.0, H. 18.95 m. Mitra. L.26

Note: One further fragment with temple integrated in the bottom is to be found registered as no. So III A 1995.

13. Votive tank in the form of a narrow yard with presumably four houses clustering around it. Three of the houses are fully preserved. They have domed roofs with three peaks each which correspond to the pinnacles on stable structures. The houses are joined in a right angle and encircle a small courtyard. Their outer walls merge together with the wall of the vessel. The yard has only one entrance which leads through a passage into the court from where the other houses can be entered. Remains of a staircase in front of the entrance and some markings at the base indicate that, originally, the vessel rested on supports. A tree seems to have grown beside the entrance; traces of its crown are still visible on the roof.

The features characteristic of a tank can only be made out at its corners and by its fractured edges, the use of this object as a votive tank cannot be doubted.

18.5 × 19.5 × 12.0 cm. Colour: red. No. So I 223.
FS. 3 I 3.6/Ca 16.9, H. 18.90 m. Mitra. L.26

14. Round votive tank. Two lamp-cups and traces of a third one are preserved upon the rim of the enclosure. One ladder is applied to the inner wall. On the ground two snakes and one frog are applied.

H. 9.2 cm. Ø 20.5 cm. Colour: brown. No. So III A 3227.
FS. 2 V 14.45/Cb 9.6, H. 18.75 m. Mitra. L.25

15. Round votive tank. Strongly chaff-tempered and hand-made. One ladder applied to the inner wall. Two snakes shaped on the ground.

H. 8.8 cm. Ø 28.7 cm. Red slipped. No. So I 257.
FS. 2 V 16.0/Ca 4.2, H. 19.40 m. Mitra. L.25

Note: Fragments of staircases registered under So III A 3130; 3453.

Period IV. Votive tanks from Levels 24 to 22

16. Fragmentary votive tank with the remaining four of originally seven or eight figures of Mother Goddesses seated on the bottom with a bowl in their lap. As to the figures and the use of the tank see the description under no. 79 of the human terracotta figurines.

26.0 × 26.0 × 14.8 cm. Colour: brown with red slip.
No. So I 325. FS. 2 V 1.3/Cc 5.5, H. 18.85 m.
Early Kṣatrapa. L.24

17. Mutilated basin of a votive tank of type B. Remains of two birds upon the rim of the enclosure walls. Fracture mark at the spot where the temple platform joined the walls and two stubs on the bottom, indicating columns which originally supported the structure. No aquatic animals on the ground.

31.3 × 24.5 × 9.6 cm. Colour: red. No. So III A 2688.
FS. 2 V 13.9/Cb 11.9, H. 19.25 m. Kṣatrapa. L.23

18. Fragment of a round votive tank with traces of two lamp-cups and a ladder applied to both sides of the wall.

H. 9.6 cm. L. 20.8 cm. Colour: red. No. So III A 3304.
FS. 2 IV 14.5–2 V 0.5/Ca 7.0–9.5, H. 20.35–20.05 m.
Kṣatrapa. L.23

Note: Further fragments with ladders on both sides registered as finds nos. So III A 1977; 3347.

Period V. Votive tanks from Levels 22 to 15

19. Fragmentary votive tank with four figures seated in rows of two on opposite sides of the enclosure. Three of the figures are preserved, of the fourth only traces are visible.

23.0 × 18.0 × 4.5 cm. Colour: brown. No. So III A 2037.
FS. 3 I 2.6/Cb 2.0, H. 20.63 m. Early Kuṣāṇa. L.21

20. Fragment of a votive tank with seated human figure of primitive shape.

H. 6.6 cm. B. 9.0 cm. Colour: red. No. So I 306.
FS. 2 IV 8.6/Ca 14.5, H. 21.60 m. Kuṣāṇa. L.21

Note: Further fragments of seated human figures from votive tanks of this period registered under So III A 2190; 3168.

21. Votive bowl. Wheel-made. Surface of vessel strongly grooved. Remains of a bird (?) upon broad rim.

Ø 28.4 cm. Colour: brick-red. No. So II 2129.
FS. 3 I 3.6/Cb 0.4, H. 20.40 m. Early Kuṣāṇa. L.22/21

Note: Further fragments of this type of bowl registered as finds nos. So II 1989; So III A 2295; 2368; 2817.

22. Votive bowl with four birds upon broad rim. Wheel-made, grooved as no. 21. On the ground a snake, frog and fish.

Ø 29.8 cm. Colour: brick-red. No. So I 199.
FS. 2 V 10.5/Cb 4.5, H. 21.85 m. Kuṣāṇa. L.20

Note: Further fragments of votive bowls of this type registered under So II 2098; So III A 1669; 2710.



1

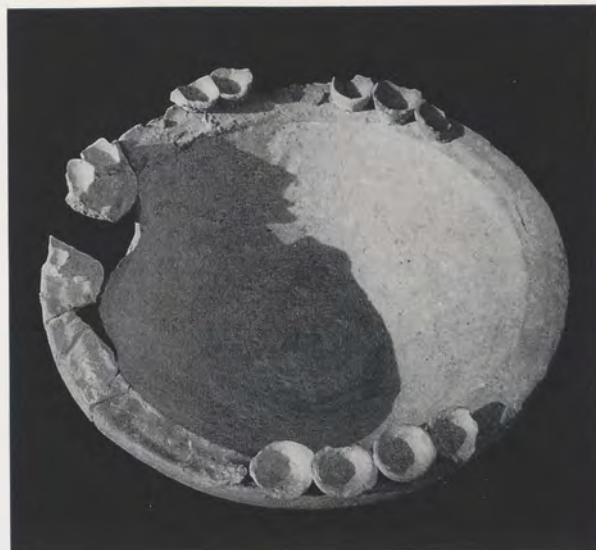

2



3



4



5

3

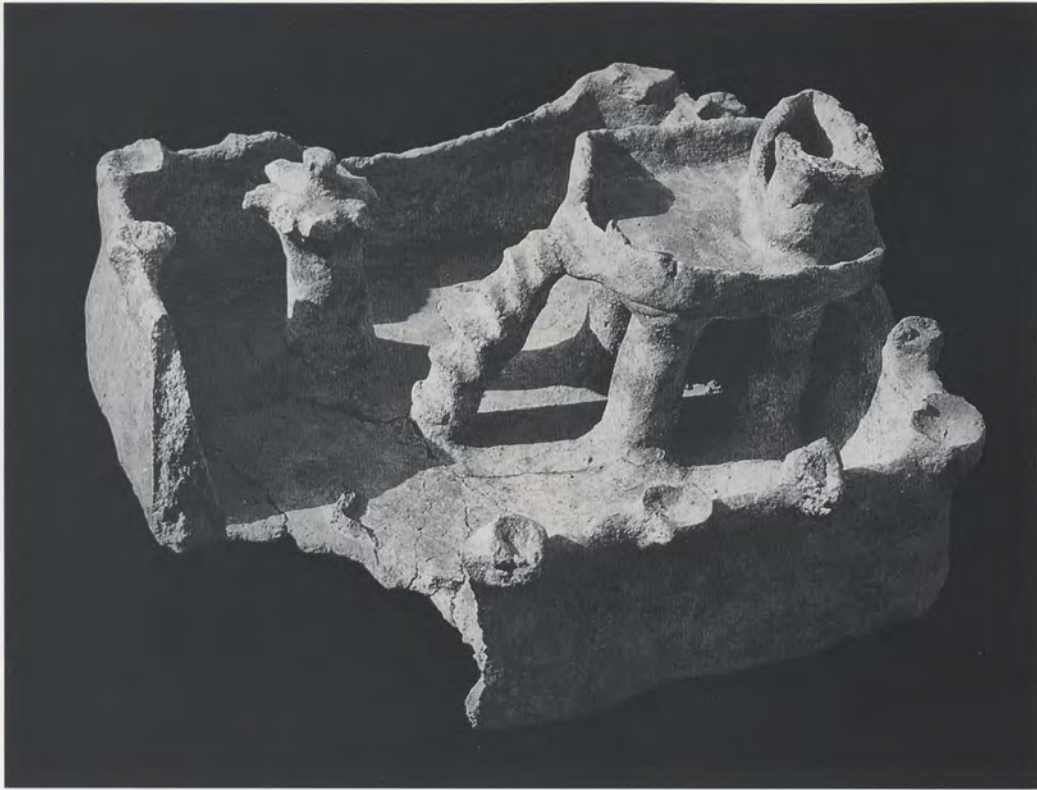

6



8



7



9



10



11



13a



12

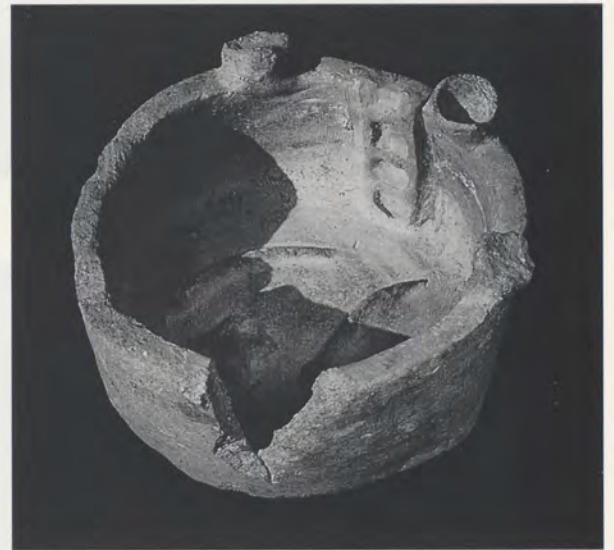

14



13b



15

3



16a



16b



17



18



19



20



21

3



22



23



24



25



26

23. Fragmentary votive tank of rectangular shape and with alternating birds and lamp-cups upon the rim. On the ground a snake and a tortoise facing each other.

H. 9.3cm. L. 29.0cm. Colour: brown. No. So I 148.

FS.2 IV 15.3/Ca 16.7, H. 23.60m. Late Kuṣāṇa. L.16

24. Fragment of rectangular votive tank with a ladder applied to the wall.

H. 8.2cm. B. 10.0cm. Colour: brown. No. So III A 1028.

FS. 2 IV 13.65/Cb 19.4, H. 22.80m. Kuṣāṇa. L.17

25. Fragment of a votive tank with ladder.

H. 5.8cm. L. 16.6cm. Colour: red. No. So III A 900.

FS. 2 V 0.5–5.5/Cc 0.5–5.5, H. 23.80–23.30m. L.15/14

Note: Further fragment with ladder and snake registered as find no. So III A 813.

Period VI. Votive tanks from Levels 15 to 12

26. Votive tank and water jug found side by side. Remains of birds or lamps upon rim which is provided with a spout on one side. One ladder each on the other three sides of the enclosure. A snake and frog (?) applied to the bottom.

31.5 × 31.0 × 8.5 cm. Jug: H. 18.5cm. Colour: brown, blackened by fire. No. So I 89–90.

FS. 2 IV 6.0–6.8/Ca 15.8–16.2, H. 25.20–24.80m.

Early Medieval. L.12

Note: One fragment of spouted votive tank similar to no. 26 registered as find no. So III A 306.

Toy-carts

The number of fragments of toy-carts found at Sonkh amounts to 41 altogether. They range from the Śuṅga Cultural Phase to the Kuṣāṇas. Many fragments are just crude parts of the platform, or the pole of a cart. Others belonged to more sophisticated and decorated types, esp. those found in the Mitra levels. These earlier carts are, as a rule, provided with not seldom impressive side-planks, either upright or slanting. The later type shows rows of holes in the platform indicating a more simple construction of the planks with the help of rods. There are no fragments of carts from Periods I and II and from a time later than the Kuṣāṇas.

Period III–IV. Toy-carts from Levels 29 to 24

1. Mutilated toy-cart with planks at the sides and in the rear. The rim of the side-planks swings outwards, being decorated with rosette-like discs. Same sort of decoration is applied to the outside of the planks, while the rear one is stamped with a grid-pattern. The axle-hole runs right through the bottom leaving a groove on the ground. On the bottom of the platform a fractured stub is visible, presumably remains of a driver. The pole of the cart is shaped like a bull's head with horns and a perforation. Curiously, two

horses were standing upon the coach-box one of which is sufficiently preserved for identification. At the rear of the cart, a hook is visible on the left while a second one is broken off on the right side. As to the wheels, see under WHEELS, no. 8.

9.0 × 16.3 × 9.0 cm. Brick-red. No. So I 203.

FS. 3 I 12.5/Ca 15.15, H. 16.60m (pit from 29).

Late Śuṅga C.P., L.29

2. Fragment of a toy-cart. Edges being decorated with impressed leaves.

H. 2.0 cm. L. 6.5 cm. Brick-red. No. So III A 3342.

FS. 2 IV 14.0–15.5/Cc 1.5–9.5, H. 17.20–17.05m.

Early Mitra. L.28

3. Fragment of a toy-cart showing curved pole ending in a hook. A perforation for the yoking runs through the pole, but those for the wheels are pierced through pending semicircular axle-holders attached to the middle of the cart.

L. 13.1 cm. B. 6.4 cm. Brick-red. No. So III A 2219.

FS. 3 I 6.0/Ca 16.7, H. 17.90m. Mitra. L.27

Note: Further fragments with pending axle devices from L.27 registered as nos. So III A 2167; 2217.

4. Thill of a toy-cart.

L. 6.7 cm. B. 6.1 cm. Brown. No. So III A 2166.

FS. 3 I 5.1/Ca 16.4, H. 18.05m. Mitra. L.27

5. Tongue of a toy-cart. Vertical perforation for yoking animals to the cart. Side-planks broken off.

L. 5.0 cm. B. 2.9 cm. Brick-red. No. So III 3003.

FS. 2 V 2.8–4.5/Ca 9.5–15.5, H. 18.64–18.40m.

Mitra. L.26

Note: One further specimen with perforated tongue registered as find no. So III A 3649.

6. Fragment of a toy-cart. Bottom decorated with stamped grid, slanting side-plank with vertical grooves. Outer sides plain. Traces of applied axle-holder on one side of the base.

L. 8.5 cm. B. 6.0 cm. Brick-red. No. So III A 3378.

FS. 2 V 10.5–16.2/Cb 13.4–16.0, H. 18.75–18.55m.

Mitra. L.25

7. Side-plank of a toy-cart decorated with moulded rosettes.

L. 8.4 cm. Colour: brick-red. No. So III A 2694.

FS. 2 V 2.0–4.0/Ca 12.3–15.0, H. 19.75–19.50m.

Kṣatrapa. L.24

Note: One further fragment with applied rosettes: So III A 2488.

Period V. Toy-carts from Levels 22 to 15

8. Platform of a toy-cart. Perforated for the axle in the middle of the length. On the long sides of the bottom a line of presumably eleven holes each for fastening rods.

8.1 × 5.7 cm. Colour: brick-red. No. So III A 1503.

FS. 2 IV 0.5–6.0/Cb 16.0–19.5, H. 22.02–21.57m.

Kuṣāṇa. L.20/19.

Note: One further fragment of same type registered as So III A 751

9. Fragment of the platform of a toy-cart with originally six vertical holes for the rods. At the small side a shallow excavation and a large hole for fastening a cart-pole is visible.

H. 1.6 cm. L. 3.2 cm. Brick-red. No. So III A 915.

FS. 15.0–18.0/Cb 4.0–5.0, H. 22.70–22.40m.

Kuṣāṇa. L.18

Note: Further fragments from Period V with six rod-holes in the platform registered as finds nos. So III A 669; 949; 1289; 2092.

4

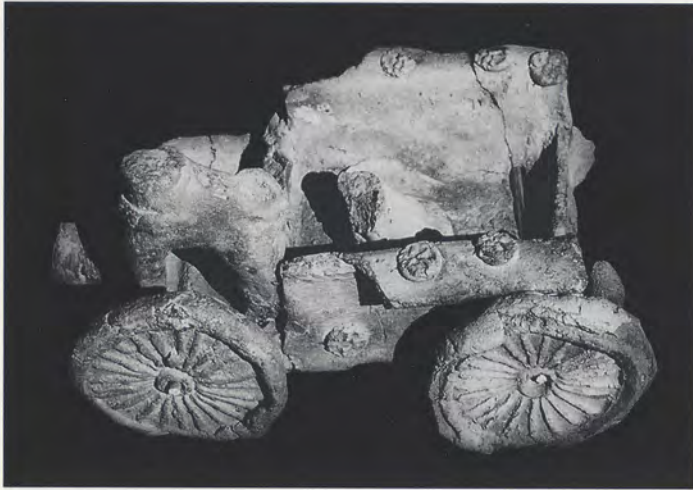

1



5



2



3



4



6



7



8



9

Terracotta Toy-carts. Period III-IV (1-7), Period V (8-9)

Wheels

Of all the 291 specimens of terracotta wheels recovered at Sonkh, 247 of them are plain and 44 decorated mostly with spokes. The diameter varies between 2.3 and 9.2 cms, indicating that the wheels were transporting objects of different size, like toy animals and carts. The finds hail from levels 34 to 14, i.e. from period II to VI. Several plain types appear through all these periods though with some variations in details, as e.g. the structure of the axle-hubs. Lenticular wheels (no. 16) have been found only from level 23 onwards, and types with strongly protruding axles (nos. 19, 21, 23–25) came to light exclusively in the Kuṣāṇa levels. The decoration with spokes, as a rule moulded, begins with the Śuṅga Cultural Phase and is quite in fashion in the Mitra time of Mathura. The number of spokes varies in between 9 and 34 but obviously without any deeper meaning. From a later period, very few specimens only of decorated wheels are known, their decorations being clumsily incised (nos. 24–26).

Period II–III. Wheels from Levels 34 to 24

1. Double-convex wheel. Crudely made.
Diam. 4.5 cm. Colour: grey. No. So III A 1961.
FS. 3 I 10.8/Ca 16.3, H. 14.50 m. Maurya. L.34
2. Wheel with pricked holes around axle-perforation.
Diam. 3.7 cm. Colour: brown. No. So III A 3638.
FS. 2 IV 6.5–10.5/Cc 3.8–5.5, H. 15.85–15.65 m.
Maurya. L.33/32
3. Wheel. Both sides plane with thrown up edges around perforation.
Diam. 7.1 cm. Colour: brown. No. So III A 3400.
FS. 2 IV 2.0–4.2/Cc 8.1–9.5, H. 15.80–15.70 m.
Maurya. L.33/32
Note: 18 further specimens of this type from period II/III registered under So III A. Diameter between 3.3 and 7.0 cm.
4. Wheel. Both sides plane surface.
Diam. 7.2 cm. Colour: brown. No. So III A 3466.
FS. 2 IV 17.–18.15/Cc 0.5–9.5, H. 16.30–15.15 m.
Late Maurya. L.32/31
Note: 35 further wheels of this type from period II/III registered under So III A. Diameter between 3.0 and 7.2 cm.
5. Wheel with prominent hub on the obverse. Reverse plain.
Diam. 2.9 cm. Colour: grey. No. So III A 3695.
FS. 2 IV 11.2–14.8/Cc 8.5–9.5, H. 16.00–15.80 m.
Maurya. L.32
Note: 5 further wheels of this type from Period II/III registered under So III A. Diameter between 4.0 and 6.1 cm.
6. Wheel with 9 moulded spokes around a prominent hub on the obverse. Reverse plain and uneven.
Diam. 8.2 cm. Colour: brown. No. So III A 3309.
FS. 2 IV 12.7–14.0/Cc 0.5–9.5, H. 17.20–17.05 m.
Early Mitra. L.28
7. Wheel with 12 moulded spokes around a hub on the obverse. Reverse plain.
Diam. 8.4 cm. Colour: red. No. So III A 1587.
FS. 3 I 6.5–8.9/Ca 14.85–17.6, H. 18.68–17.80 m.
Mitra. L.27/26
Note: 6 further wheels with 12 and one with 18 spokes from Period II/III registered under So III A. Diameter between 7.0 and 8.3 cm.

8. Wheel with 22 moulded spokes around thrown up edge of perforation hole.

Diam. 6.5 cm. Colour: brown. No. So III A 2355.

FS. 3 I 8.2/Ca 14.0, H. 17.80 m. Early Mitra. L.28

Note: 2 further wheels with 22 spokes registered under So III A. Diameter 6.2–6.5 cm.

9. Moulded wheel with prominent central hub from which 21 spokes radiate. At the ends of the spokes an elevated dot each. Reverse plane.

Diam. 7.1 cm. Colour: brown. No. So III A 2593.

FS. 2 V 11.7/Ca 3.5, H. 18.80 m. Mitra. L.26

Note: 5 further wheels of this type with varying number of spokes (13, 17, 20, 24) from Period III registered under So III A. Diameter between 4.7 and 8.7 cm.

10. Moulded wheel with 32 spokes around central hub. Dot between the ends of two spokes each.

Diam. 7.3 cm. Colour: red. No. So III A 1589.

FS. 3 I 6.5–8.9/Ca 14.85–17.6, H. 18.68–17.80 m.

Mitra. L.27/26

Note: 2 further specimens with 32 spokes under So III A.

11. Moulded wheel with three-stepped central hub encircled by a lower wreath and an elevated rim with short spokes as well as a plain outer ring with upturned edge. Reverse plane.

Diam. 6.65 cm. Colour: red. No. So III A 1474.

FS. 3 II 0.0–1.75/Ca 16.5–19.5, H. 18.24–17.75 m.

Mitra. L.28/27

12. Wheel with two-stepped central hub radiating 34 short spokes towards upturned edge. Reverse plane.

Diam. 7.2 cm. Colour: red slip. No. So III A 1586.

FS. 3 I 6.5–8.9/Ca 14.85–17.6, H. 18.68–17.80 m.

Mitra. L.27/26

Note: One further specimen of same 34-spokes' type registered as So III A 1585.

Period IV–VI. Wheels from Levels 24 to 15

13. Plane wheel. Crudely modelled.

Diam. 4.2 cm. Colour: grey. No. So III A 2649.

FS. 2 V 4.0–5.0/Ca 19.0–19.5, H. 20.30–20.15 m.

Kṣātrapa. L.23

Note: 7 further wheels of this type from Period IV registered under So III A. Diameter between 3.2 and 5.3 cm.

14. Plain wheel with small hub.

Diam. 4.7 cm. Colour: brown. No. So III A 3223.

FS. 2 V 13.5–15.9/Cb 11.0–13.75, H. 18.95–18.70 m.

Early Kṣātrapa. L.24

Note: 10 further wheels of same type registered under So III A. Diameter between 3.3 and 6.0 cm.

15. Plano-convex wheel with slightly elevated centre.

Diam. 5.7 cm. Colour: brown. No. So III A 3114.

FS. 2 V 0.5–2.3/Cb 9.5–10.5, H. 19.35–19.05 m.

Kṣātrapa. L.24/23

Note: 11 further wheels of same type registered under So III A. Diameter between 2.7 and 6.0 cm.

16. Lenticular wheel with flat hub.

Diam. 3.8 cm. Colour: brown. No. So III A 2021.

FS. 2 V 16.3–20.0/Ca 17.3–19.5, H. 20.55–20.25 m.

Kṣātrapa. L.23

17. Wheel. Both sides plane. Perhaps used as spindle-whorl.
Diam. 2.1 cm. Colour: grey. No. So III A 808.
FS. 2 V 1.5–4.0/Ca 2.5–4.6, H. 22.90–22.60 m.
Kuṣāṇa. L.18
Note: Further 18 wheels of same type from Period V registered under So III A. Diameter between 3.5 and 9.4 cm.
18. Plano-convex wheel with small hub.
Diam. 6.0 cm. Colour: brown. No. So III A 2993.
FS. 2 V 5.0–9.0/Cb 18.0–19.5, H. 20.60–20.40 m.
Kuṣāṇa. L.22/21
Note: 5 further wheels of same type registered under So III A. Diameter between 3.4 and 6.6 cm.
19. Double-convex wheel with prominent hub.
Diam. 2.9 cm. Colour: brown. No. So III A 867.
FS. 2 V 3.0–9.5/Ca 19.3–19.5, H. 21.90–21.60 m.
Kuṣāṇa. L.20
Note: 47 further wheels of same type from Period V registered under So III A. Diameter between 2.5 and 8.8 cm.
20. Double-convex wheel with on both sides protruding hubs.
Diam. 4.2 cm. Colour: grey. No. So III A 2077.
FS. 2 IV 9.5–10.5/Ca 1.0–4.75, H. 22.05–21.80 m.
Kuṣāṇa. L.20
Note: 8 further wheels of same type registered under So III A. Diameter between 3.3 and 4.8 cm.
21. Double-convex wheel with strongly protruding hubs on both sides.
Diam. 7.6 cm. Colour: brown. No. So III A 1329.
FS. 2 IV 3.0–6.0/Ca 3.0–6.3, H. 22.50–22.25 m.
Kuṣāṇa. L.19
Note: 2 further wheels with double hubs registered under So III A. Diameter 3.5 and 3.9 cm.
22. Lenticular wheel.
Diam. 4.5 cm. Colour: brown. No. So III A 2457.
FS. 2 V 9.5–10.5/Ca 17.0–19.5, H. 20.90–20.60 m.
Kuṣāṇa. L.22
Note: 21 further wheels of lenticular type from Period V registered under So III A. Diameter between 3.3 and 6.2 cm.
23. Big plain wheel with broad hubs.
Diam. 8.8 cm. Colour: brown. No. So III A 2869.
FS. 2 IV 10.5–11.35/Ca 8.8–9.5, H. 22.30–21.80 m.
Kuṣāṇa. L.20/19
24. Fragment of big wheel with on both sides protruding hubs. Arbitrary impression of semicircles along the edge.
Diam. 8.0 cm. Colour: grey-brown. No. So III A 2704.
FS. 2 IV 11.5–19.5/Cb 2.0–3.5, H. 21.88–21.55 m.
Kuṣāṇa. L.21/20
25. Double-convex wheel with protruding hubs. Clumsily incised spokes at both sides.
Diam. 4.2 cm. Colour: brown. No. So III A 1303.
FS. 2 V 12.2/Cb 8.2, H. 21.40 m. Kuṣāṇa. L.20
26. Lenticular wheel with protruding hubs. Incised strokes on obverse.
Diam. 3.4 cm. Colour: grey. No. So III A 1274.
FS. 2 IV 7.5–9.5/Ca 0.5–2.5, H. 22.60–22.10 m.
Kuṣāṇa. L.19
Note: 2 further fragments of same type of wheels registered under So III A.
27. Plano-convex wheel. Central hub encircled by punched holes.
Diam. 4.0 cm. Colour: grey. No. So III A 1718.
FS. 2 V 6.0–8.0/Cb 0.5–9.5, H. 21.53–21.10 m.
Kuṣāṇa. L.20
28. Plane wheel. One side rough.
Diam. 4.3 cm. Colour: red. No. So III A 511.
FS. 2 V 16.5–18.3/Ca 16.2–19.5, H. 23.35–23.00 m.
Kuṣāṇa. L.16
Note: 4 further wheels of same type registered under So III A.
29. Lenticular wheel.
Diam. 4.5 cm. Colour: brown. No. So III A 766.
FS. 2 IV 19.5–2 V 0.5/Ca 10.5–17.5, H. 24.50–24.15 m.
Gupta. L.14
30. Wheel with big hubs.
Diam. 3.5 cm. Colour: red. No. So III A 662.
FS. 2 IV 2.5–4.5/Cb 2.0–9.5, H. 24.25–23.95 m.
Gupta. L.14
Note: One further wheel of same type from L.14 under So III A 837



1



2



3

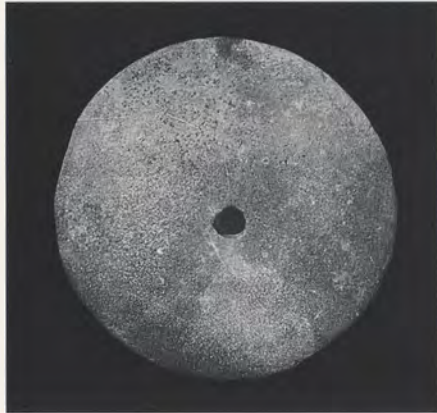

4



5



6



7



8



9



10



11



12

5



13



14



15



16



17



18



19



20



21



22



23



24



25

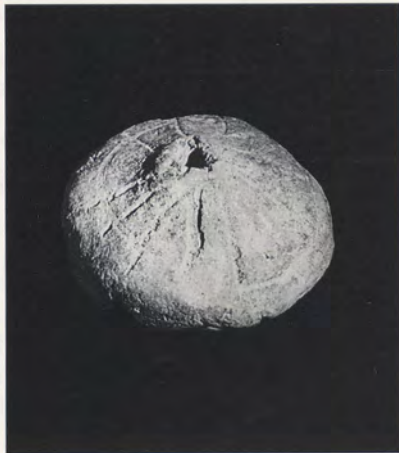

26



27



28



29

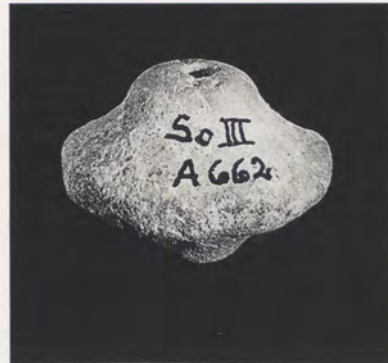

30

Discs

The number of terracotta discs found in the excavation amounts to 192. Of them 67 are just plain or made of potsherds while 125 show decorations of different kind. The most frequent patterns are straight or oblique notches incised in varying density on the edges of the discs of all periods. The second frequent design is the scalloped border, i.e. the incision or impression of semicircles or crescents around the circumference of the disc. In addition, a restricted number of discs show individual incisions on the plane surfaces. The diameters of the discs range from 2.2 to 7.3 cm, the bulk between 3.0 and 6.0 cm, covering all 10 mm grades from 3.1; 3.2; 3.3 upto 5.8; 5.9; 6.0.

The function of the discs is a matter of discussion among scholars since long (cp. e.g. B.B.Lal 1954 & 1955, pp.87f., and R.C.Gaur 1983, pp.205ff.). From all the ideas presented, the interpretation as "gaming counters" seems to be the most probable one.

Period I-III. Discs from Levels 37 to 24

1. Mutilated disc with long oblique notches on edges.

Diam. 3.9 cm. Colour: grey. No. So III A 3128.
FS. 2 IV 8.5-10.0/Be 15.5-19.0, H. 15.70-15.60m. PGW. L.37

2. Mutilated disc with impressed semicircles on edge and a combination of such arranged as a floral design on plane surface.

Diam. 4.5 cm. Colour: red. No. So III A 3085.
FS. 2 IV 8.0/Be 16.2, H. 16.10m. Early Maurya. L.36

3. Mutilated disc with deeply impressed semicircles along the edge.

Diam. 4.5 cm. Colour: grey. No. So III A 3644.
FS. 2 IV 12.0-15.0/Cc 1.65-3.25, H. 15.05-14.90m.
Early Maurya. L.35

Note: Two more specimens with scalloped border from Period II and III registered under So III A. Diameter 3.7 and 5.9 cm.

4. Disc with short and broad notches on edges.

Diam. 5.1 cm. Colour: brown. No. So III A 2615.
FS. 3 I 5.2-7.5/Ca 7.0-9.0, H. 15.80-15.70m.
Maurya. L.35

Note: 3 more specimens of same type from periods II/III registered under So III A. Diameter between 3.0 and 5.7 cm.

5. Disc with thin oblique notches on edges.

Diam. 4.75 cm. Colour: brown. No. So III A 1990.
FS. 3 I 10.8-11.9/Ca 16.3-17.5, H. 11.75-11.25m.
From well. Maurya. L.34

Note: 11 more specimens with thin notches from Periods II/III registered under So III A. Diameter between 3.3 and 6.5 cm.

6. Disc with regular straight notches on edges.

Diam. 5.8 cm. Colour: brown. No. So III A 2989.
FS. 2 IV 4.5/Be 13.6, H. 19.20m. Early Mitra. L.28

7. Disc with long irregularly radiating incised notches on plane surface and edge of one side.

Diam. 4.3 cm. Colour: brown. No. So III A 3621.
FS. 2 IV 2.6-5.85/Cc 0.65-4.8, H. 15.75-15.60m.
Maurya. L.32

8. Plain disc.

Diam. 5.0 cm. Colour: brown. No. So III A 3572.
FS. 2 IV 7.1-10.5/Cc 0.5-2.5, H. 16.55-16.40m.
Late Maurya/Śuṅga C.P., L.31/30

Note: Two more plain discs from Period II registered under So III A. Diameter 4.1 and 4.4 cm.

9. Disc made from a potsherd.

Diam. 4.3 cm. Colour: greybrown. No. So III A 2140.
FS. 3 I 7.4-10.0/Ca 11.2-15.0, H. 18.30-18.15m.
Mitra. L.27

Note: 3 further discs of potsherds registered under So III A. Diameter 2.6, 3.6 and 3.9 cm.

Period IV-V. Discs from Levels 24 to 15

10. Mutilated disc with oblique incised notches gradated in groups.

Diam. 3.2 cm. Colour: greybrown. No. So III A 3658.
FS. 3 I 1.3-2.0/Cb 15.4-19.5, H. 19.12-18.78m.
Early Kṣātrapa. L.24

Note: 3 more discs of same type from period IV registered under So III A. Diameter 3.1, 4.1 and 4.5 cm.

11. Cake-shaped disc with irregularly incised notches on rounded edges.

Diam. 3.4 cm. Colour: brown. No. So III A 1265.
FS. 2 IV 5.0-9.5/Ca 16.0-18.3, H. 22.60-22.30m.
Kuṣāṇa. L.19

Note: 16 more specimens of same type from period V registered under So III A. Diameter between 3.5 and 6.5 cm.

12. Disc with thin notches along the edges.

Diam. 3.8 cm. Colour: grey. No. So III A 2798.
FS. 2 IV 19.5-2 V 0.5/Be 19.0-19.8, H. 22.66-22.30m.
Kuṣāṇa. L.20

Note: 8 further specimens of same type from period V registered under So III A. Diameter between 3.4 and 6.8 cm.

13. Disc with wide-set notches along edges and painted black grid on either side of the plane surfaces.

Diam. 3.9 cm. Colour: greybrown. No. So III A 1036.
FS. 2 IV 10.5-15.5/Ca 14.3-16.2, H. 23.83-23.73m.
Late Kuṣāṇa. L.16

14. Disc with irregular notches around the circumference.

Diam. 2.5 cm. Colour: lightbrown. No. So III A 1782.
FS. 2 V 19.5-3 I 0.5/Ca 10.5-19.5, H. 23.02-22.62m.
Kuṣāṇa. L.18/17

15. Disc with flatly incised crescents along the edges.

Diam. 5.7 cm. Colour: red. No. So III A 1074.
FS. 2 IV 17.0-19.5/Be 18.5-Ca 2.5, H. 23.32-22.97m.
Kuṣāṇa. L.18/17

Note: 3 more discs with flat scalloped border from Period V registered under So III A. Diameter 3.5, 4.2 and 5.5 cm.

16. Disc with deeply impressed semicircles along the edges.

Diam. 4.5 cm. Colour: red. No. So III A 618.
FS. 2 IV 12.0-14.0/Be 16.0-17.5, H. 24.30-24.00m.
Late Kuṣāṇa. L.16

Note: One more disc of same type registered under So III A. Diameter 3.8 cm.

17. Plain disc.

Diam. 3.1 cm. Colour: red. No. So III A 1078.
FS. 2 IV 18.5-19.5/Cb 19.5-Cc 0.5, H. 22.92-22.42m.
Kuṣāṇa. L.17

Note: 18 more plain discs from Periods IV/V registered under So III A. Diameter between 2.2 and 7.3 cm.

18. Thick plain disc.

Diam. 2.9 cm. Colour: brown. No. So III A 817.
FS. 2 IV 16.0-19.5/Cb 2.3-2.7, H. 23.65-23.30m.
Late Kuṣāṇa. L.16

Note: 3 more thick discs from Period V registered in group So III A. Diameter between 3.05 and 3.7 cm.

19. Thick disc with a circle of punched holes on both sides. Diam. 3.4 cm. Colour: light brown. No. So III A 1237. FS. 2 IV 6.5/Be 16.1, H. 22.00 m. Kuşāṇa. L.20

20. Mutilated disc with notches along the edges and crudely incised motifs, one on each side, consisting of 1) a house with tree and a cross-road in front, and 2) an indistinct scene (chariot with team?).

Diam. 5.6 cm. Colour: brown. No. So III A 1000. FS. 2 IV 13.5–15.0/Cb 11.0–11.5, H. 22.20–22.05 m. Kuşāṇa. L.18

21. Mutilated disc with crudely incised tree(?) on the one and a simple cross on the other side.

Diam. 4.8 cm. Colour: red. No. So III A 1783. FS. 2 V 19.5–3 I 0.5/Ca 10.5–19.5, H. 23.02–22.62 m. Kuşāṇa. L.18/17

22. Disc with crudely incised floral motifs one on each side.

Diam. 4.4 cm. Colour: light brown. No. So III A 890. FS. 2 V 10.5–17.25/Cc 11.0–16.0, H. 23.23–21.93 m (pit). Kuşāṇa. L.18–15

23. Disc with incised floral(?) motif consisting of zigzag-lines and dots.

Diam. 3.5 cm. Colour: red. No. So III A 312. FS. 2 IV 18.0–19.5/Be 18.0–Ca 9.5, H. 25.00–24.70 m. Late Kuşāṇa. L.16/15

Period VI–VIII. Discs from Levels 15 to 1

24. Disc with sharply cut notches on edges.

Diam. 5.2 cm. Colour: dark brown. No. So III A 385. FS. 2 III 19.0–2 IV 7.0/Ca 4.5–6.5, H. 24.90–24.60 m. Gupta. L.15

Note: 11 more discs of same type from Periods VI/VIII registered under So III A. Diameter between 3.1 and 5.5 cm.

25. Disc with carefully incised oblique notches around the edges.

Diam. 3.5 cm. Colour: red. No. So III A 283. FS. 2 V 0.5–5.0/Ca 14.3–16.2, H. 25.30–25.00 m. Medieval. L.11

Note: 2 more discs registered under So III A. Diameter 3.5 and 5.2 cm.

26. Mutilated disc with sharply impressed shallow crescents on edges.

Diam. 6.2 cm. Colour: red. No. So III A 603. FS. 2 IV 0.5–3.5/Ca 14.0–16.0, H. 24.10–23.80 m. Gupta. L.15

Note: 2 more discs with crescent-border registered under So III A. Diameter 4.0 and 5.0 cm.

27. Disc with impressed chevrons on edges.

Diam. 4.7 cm. Colour: red. No. So III A 871. FS. 2 V 0.5–1.5/Cc 5.0–7.5, H. 23.30–23.00 m. Gupta. L.15

Note: 2 more discs with same pattern registered under So III A. Diameter 3.3 and 3.8 cm.

28. Plain disc.

Diam. 2.8 cm. Colour: brown. No. So III A 391. FS. 2 IV 15.0–17.8/Ca 5.0–9.5, H. 25.15–24.70 m. Medieval. L.12

Note: 11 more plain discs from periods VI/VIII registered under So III A. Diameter between 2.5 and 6.8 cm.

29. Disc with two lines of punched holes crossing each other.

Diam. 3.5 cm. Colour: brown. No. So III A 443. FS. 2 IV 1.5–3.5/Be 16.0–19.5, H. 25.90–24.70 m. Gupta. L.14

30. Disc with geometrical pattern incised on both sides.

Diam. 4.5 cm. Colour: brown. No. So III A 566. FS. 2 V 6.0–14.5/Cb 10.5–12.5, H. 25.65–25.25 m. Medieval. L.10

31. Disc with oblique notches on edges and incised floral (or stylized sun) motifs on either side.

Diam. 4.0 cm. Colour: brown. No. So III A 290. FS. 2 V 11.0–15.0/Ca 7.7–9.5, H. 25.67–25.27 m. Medieval. L.9

6



1



2



3



4



5



6



7



8



9

Terracotta Discs. Period I-III



10



11



12



13



14



15



16



17



18



19



20a



20b

6



21



22



23



24



25



26



27



28



29



30

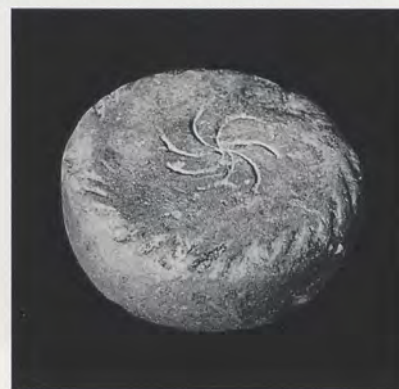

31

Spindle-whorls

In all 321 terracotta spindle-whorls of different shapes have been found in the levels of Periods II to VIII. Half of them comes from Period V, i.e. the Kuṣāṇa levels. The earliest whorls at Sonkh belong to the time of the Mauryas, the latest to the Jāts.

These objects, often identified as beads in Indian publications, can be divided in three groups

- A. The vase shaped type with prominent collar and circular, elongated or truncated body;
- B. The arecanut shaped type of hard lathe-made structure;
- C. The rare types of different design, like spheroid, pear shaped, etc.

In view of the large number of such whorls one is inclined to classify them according to sub-shapes and to follow up the first appearance and, possibly, the re-appearance of a special shape in the succeeding periods. But one has to be aware of the fact that not one whorl is of exactly the same shape as the other. Therefore they can be classified only tentatively. It is to prefer to present the whorls according to their appearance within the respective periods. For this purpose one typical specimen of each variety found in the levels of the Periods II to IV, V, and VI to VIII has been selected and depicted here, amounting to altogether 54 specimens. The bulk of the remaining undamaged whorls has been allotted to the one or the other of these specimens in footnotes.

Period II–IV. Spindle-whorls from Levels 34 to 23

1. Spheroid-shaped; rough perforation.
Ø 2.6 cm. Colour: grey. No. So III A 1970.
FS. 3 I 10.8–11.9/Ca 16.3–17.5, H. 14.20–13.70 m.
From a well. Maurya. L.34
2. Vase-shaped; squattish; overhanging rim; flat base.
Ø 2.2 cm. H. 1.2 cm. Colour: red. No. So III A 1802.
FS. 3 II 4.7–8.3/Ca 15.0–18.3, H. 16.05–15.75 m.
Maurya. L.34/33
3. Vase-shaped; circular; constricted neck; slightly overhanging round collar.
Ø 1.7 cm. H. 1.57 cm. Colour: red. No. So III A 1797.
FS. 3 II 4.8–8.3/Ca 14.5–18.2, H. 16.05–15.75 m.
Maurya. L.34/33
4. Vase-shaped; irregularly flaring sides rounded in the lower part; constricted neck; broad flat rim.
Ø 3.3 cm. H. 2.3 cm. Colour: grey. No. So III A 3055.
FS. 2 IV 4.0/Be 19.0, H. 17.30 m. Maurya. L.33
5. Vase-shaped; (squattish) circular; constricted neck; broad flat rim.
Ø 3.36 cm. H. 2.13 cm. Colour: red. No. So III A 1767.
FS. 3 II 4.7–8.3/Ca 15.75–18.0, H. 16.30–16.00 m.
Maurya. L.33
6. Arecanut-shaped; flat circular depression on top; Conically flaring sides.
Ø 2.45 cm. H. 1.7 cm. Colour: grey. No. So III A 1566.
FS. 3 I 18.0–20.0/Ca 15.8–19.5, H. 17.47–17.07 m.
Late Śuṅga C.P., L.29
7. Arecanut-shaped; deep circular depression on top; grooves around shoulders.

Ø 2.8 cm. H. 2.6 cm. Colour: grey. No. So III A 1405.
FS. 3 I 12.0–14.0/Ca 14.2–17.0, H. 18.19–17.84 m.
Early Mitra. L.28/27

8. Arecanut-shaped; common type; large circular depression on top; grooves around shoulder and body.

Ø 2.35 cm. H. 1.6 cm. Colour: grey. No. So III A 1379.
FS. 3 II 5.3–8.8/Ca 14.0–17.0, H. 18.85–18.55 m.
Mitra. L.26

Note: 19 further specimens of same type from periods III/IV registered under So III A. Diameter between 2.2 and 3.2 cm, the bulk 2.4 cm. Height between 1.6 and 2.4 cm.

9. Arecanut-shaped; truncated top; flat base.

Ø 2.5 cm. H. 1.7 cm. Colour: red. No. So III A 1365.
FS. 3 II 0.0–5.0/Ca 16.5–19.5, H. 18.85–18.55 m.
Mitra. L.26

10. Arecanut-shaped; flat depression on top. Grooves around shoulder and body; one prominent groove in lower part.

Ø 2.3 cm. H. 1.8 cm. Grey. No. So III A 1793.
FS. 3 I 6.0–7.5/Ca 7.0–10.3, H. 19.90–19.50 m.
Mitra. L.25

Note: One more specimen registered under So III A 1821.

11. Arecanut-shaped; large depression on top marked with concentric circles; body damaged but presumably grooved.

Ø 2.3 cm. H. 1.5 cm. Grey. No. So III A 1773.
FS. 3 I 6.0–9.4/Ca 7.0–10.3, H. 19.90–19.50 m.
Mitra. L.25

12. Arecanut-shaped; narrow deep depression on top; one prominent groove around shoulder.

Ø 2.45 cm. H. 1.5 cm. Light brown. No. So III A 1738.
FS. 3 I 3.0–6.4/Ca 5.5–10.0, H. 20.14–19.90 m.
Late Mitra. L.25/24

13. Arecanut-shaped; large shallow depression on top; less tapering middle part of body; grooved around shoulder and body.

Ø 2.4 cm. H. 1.9 cm. Colour: red. No. So III A 1941.
FS. 3 I 1.4–4.5/Ca 11.5–14.5, H. 20.10–19.70 m.
Late Mitra. L.25/24

14. Vase-shaped; circular; incurved rounded collar; roughly rounded base.

Ø 2.1 cm. H. 1.85 cm. Red slipped. No. So III A 1079.
FS. 3 I 5.8–9.0/Ca 13.0–19.5, H. 20.05–19.75 m.
Late Mitra. L.25/24

Note: One more piece of same type registered under So III A 1988. Diameter 1.8 cm.

15. Arecanut-shaped; large depression on top with framing groove on edge; thrown-up perforation.

Ø 2.5 cm. H. 2.0 cm. Colour: red. No. So III A 2079.
FS. 3 I 3.0–5.4/Ca 19.8-Cb 1.6, H. 20.75–20.40 m.
Kṣatrapa. L.23

16. Arecanut-shaped; narrow, deep depression on top; chamfered shoulder.

Ø 2.33 cm. H. 1.85 cm. Grey. No. So III A 1714.
FS. 2 V 15.5–16.5/Ca 16.0–18.0, H. 20.90–20.60 m.
Late Kṣatrapa. L.23/22

17. Vase-shaped; elongated rounded body; slightly angular collar.

Ø 2.35 cm. H. 2.18 cm. Red. No. So III A 1442.
FS. 2 IV 17.0–19.4/Cc 2.5–5.2, H. 20.30–20.10 m.
Late Kṣatrapa. L.22

Period V. Spindle-whorls from Levels 22 to 15

18. Vase-shaped; squattish; rounded collar; extremely small.

Ø 1.77 cm. H. 1.2 cm. Grey. No. So III A 1461.

FS. 2 IV 2.0–6.0/Cb 14.0–19.5, H. 21.52–21.37 m.

Kuşāṇa. L.21

19. Vase-shaped; low; tapering squattish body; massively overhanging rounded rim.

Ø 1.6 cm. H. 0.8 cm. Colour: red. No. So III A 773.

FS. 2 V 0.5–18.5/Ca 17.4–19.5, H. 22.10–21.80 m.

Kuşāṇa. L.20

20. Vase-shaped; low; rounded body; bevelled broad rim.

Ø 1.8 cm. H. 1.1 cm. Red, black-slipped. No. So III A 2055.

FS. 2 IV 19.5–2 V 0.5/Ca 10.5–18.0, H. 22.56–22.30 m.

Kuşāṇa. L.19

21. Vase-shaped; short truncated cone; broad bevelled rim.

Ø 1.9 cm. H. 1.3 cm. Colour: red. No. So III A 1222.

FS. 2 IV 12.3–14.8/Be 19.5–Ca 3.0, H. 22.50–22.30 m.

Kuşāṇa. L.19

Note: Further 3 specimens of same type from period V registered under So III A. Diameter between 1.9 and 2.8 cm.

22. Vase-shaped; elongated body; rounded collar.

Ø 2.9 cm. H. 2.9 cm. Colour: red. No. So III A 1240.

FS. 3 I 2.3–6.0/Ca 16.0–17.7, H. 22.30–22.00 m.

Kuşāṇa. L.20/19

Note: One more specimen of same type registered under So III A 601.

23. Vase-shaped; slightly flaring body; rounded collar with groove on inner edge.

Ø 2.3 cm. H. 2.0 cm. Colour: red. No. So III A 1273.

FS. 2 IV 0.5–5.2/Ca 12.9–16.0, H. 22.84–22.49 m.

Kuşāṇa. L.19/18

Note: Further 4 specimens from Period V registered under So III A. Diameter between 1.7 and 2.3 cm.

24. Vase-shaped; circular; rounded collar.

Ø 2.5 cm. H. 2.2 cm. Colour: grey. No. So III A 1842.

FS. 3 I 0.5–3.5/Ca 19.5–Cb 0.5, H. 22.70–22.50 m.

Kuşāṇa. L.18

Note: 6 more specimens of same type from Period V registered under So III A. Diameter between 1.7 and 3.2 cm.

25. Vase-shaped; low rounded body; thick round collar.

Ø 1.8 cm. H. 1.4 cm. Light brown. No. So III A 992.

FS. 2 V 18.75–20.0/Cb 10.5–13.0, H. 22.50–22.20 m.

Kuşāṇa. L.18

26. Vase-shaped; circular; thick rounded collar.

Ø 2.0 cm. H. 2.5 cm. Brown by fire. No. So III A 1051.

FS. 2 IV 5.0–6.5/Cb 4.5–9.5, H. 23.53–23.28 m.

Late Kuşāṇa. L.16

27. Vase-shaped; elongated body; high rounded collar.

Ø 2.5 cm. H. 2.5 cm. Colour: red. No. So III A 762.

FS. 2 V 0.5–4.0/Ca 10.5–13.8, H. 23.15–22.85 m.

Kuşāṇa. L.18/17

28. Vase-shaped; circular; constricted neck with sharp grooves around shoulder; narrow collar.

Ø 2.8 cm. H. 2.4 cm. Colour: red. No. So III A 969.

FS. 2 IV 6.0–7.75/Cb 10.5–13.5, H. 23.67–23.27 m.

Late Kuşāṇa. L.16

29. Arecanut-shaped; large flat depression on top; grooves around shoulder and body.

Ø 2.25 cm. H. 1.9 cm. Colour: grey. No. So III A 1715.

FS. 2 V 2.5–4.3/Ca 5.0–6.4, H. 21.28–21.03 m.

Kuşāṇa. L.21

Note: Further 12 specimens of same type from Period V registered under So III A. Diameter between 2.1 and 3.5 cm.

30. Arecanut-shaped; medium but sharp concave depression on top; body tapering off to the concave bottom; no grooves.

Ø 2.6 cm. H. 2.0 cm. Colour: grey. No. So III A 857.

FS. 2 V 0.5–3.0/Ca 5.0–9.5, H. 21.60–21.30 m.

Kuşāṇa. L.21

Note: 11 more specimens of same type registered under So III A. Diameter between 1.7 and 3.2 cm.

31. Arecanut-shaped; medium depression; two deep grooves on shoulder.

Ø 2.7 cm. H. 2.2 cm. Colour: grey. No. So III A 1602.

FS. 2 V 10.5–14.5/Ca 10.5–12.3, H. 21.10–20.85 m.

Kuşāṇa. L.21

Note: Further 2 specimens with two grooves on shoulder from same period registered under So III A 476; 928. Diameter 2.5 and 2.8 cm.

32. Arecanut-shaped; narrow deep depression on top; slight bend on shoulder.

Ø 2.4 cm. H. 2.2 cm. Brown, blackened. No. So III A 1223.

FS. 2 IV 10.5–12.2/Be 15.5–Ca 3.0, H. 22.75–22.60 m.

Kuşāṇa. L.19/18

Note: Further 4 specimens of same type registered under So III A. Diameter between 2.1 and 2.6 cm.

33. Arecanut-shaped; large flat depression on top with deep grooves on edge; slightly squattish body, irregularly grooved.

Ø 2.4 cm. H. 1.8 cm. Colour: black. No. So III A 1059.

FS. 2 IV 13.5–19.5/Ca 7.0–9.5, H. 22.84–22.54 m.

Kuşāṇa. L. 19/18

Note: 3 more whorls of same type registered under So III A. Diameter between 2.3 and 3.4 cm.

34. Arecanut-shaped; narrow depression on top; edging constriction around shoulder.

Ø 3.4 cm. Ht. 2.6 cm. Colour: grey. No. So III A 1254.

FS. 2 V 0.5–9.5/Cc 0.5–0.6, H. 22.92–22.12 m.

Kuşāṇa. L.17/16

Note: 3 more specimens registered under So III A. Diameter between 2.7 and 3.3 cm.

35. Arecanut-shaped; narrow depression on top; rounded body completely grooved.

Ø 2.5 cm. H. 2.1 cm. Colour: grey. No. So III A 1827.

FS. 2 V 13.0–19.5/Ca 19.5–Cb 0.5, H. 22.70–22.30 m.

Kuşāṇa. L.18

36. Arecanut-shaped; common type; medium but deep depression on top.

Ø 2.5 cm. H. 1.9 cm. Colour: grey. No. So III A 2053.

FS. 2 IV 9.5–10.5/Ca 0.5–4.0, H. 23.19–22.80 m.

Kuşāṇa. L.18/17

Note: 29 more specimens with and without grooves around body from Period V registered under So III A. Diam. between 2.1 and 3.7 cm.

37. Arecanut-shaped; medium depression on top; body with slight bend and prominent groove on shoulder.

Ø 3.2 cm. H. 2.1 cm. Grey, black stripes. No. So III A 903.

FS. 2 V 7.0–9.5/Ca 2.0–4.5, H. 22.30–22.00 m.

Kuşāṇa. L.19

Note: Further 8 specimens of same type from Period V registered under So III A. Diameter between 2.3 and 3.5 cm.

38. Arecanut-shaped; large shallow depression on top; regular concentric grooves in field of depression and all around body.

Ø 3.4 cm. H. 2.2 cm. Colour: black. No. So III A 1055.

FS. 2 IV 0.5–4.0/Ca 7.0–8.0, H. 23.10–22.80 m.

Kuṣāṇa. L.18

Note: 11 more specimens of same type registered under So III A. Diameter between 2.5 and 3.2 cm.

39. Arecanut-shaped; narrow depression on top; chamfered neck.

Ø 3.1 cm. H. 2.1 cm. Colour: brown. No. So III A 2083.

FS. 2 III 13.0–19.5/Cb 1.6–3.5, H. 22.90–22.60 m.

Kuṣāṇa. L.18/17

Note: Further 5 specimens with chamfered neck from Period V registered under So III A. Diameter between 2.3 and 3.5 cm.

40. Arecanut-shaped; common type; large depression on top; grooves all over the body.

Ø 2.3 cm. H. 1.6 cm. Colour: brown. No. So III A 1107.

FS. 2 IV 10.5–14.0/Ca 5.4–8.0, H. 23.01–22.61 m.

Kuṣāṇa. L.18

Note: 25 more specimens of same type from Period V registered under So III A. Diameter between 2.2 and 3.6 cm.

41. Arecanut-shaped; large and deep depression on top; grooves all around the body.

Ø 2.5 cm. H. 1.6 cm. Colour: brown. No. So III A 2035.

FS. 2 III 19.2–2 IV 0.5/Ca 10.5–15.0, H. 23.20–22.95 m.

Kuṣāṇa. L.19/18

Note: 9 further specimens of same type from Period V registered under So III A. Diameter between 2.0 and 3.3 cm.

42. Arecanut-shaped; medium but flat depression on top; deep groove around neck.

Ø 3.0 cm. H. 2.0 cm. Colour: black. No. So III A 1068.

FS. 2 IV 10.5–11.6/Cb 9.5–10.5, H. 23.65–23.05 m.

Late Kuṣāṇa. L.16

Note: One more specimen with neck-groove registered under So III A 644. Diameter 2.7 cm, Ht. 1.8 cm.

Periods VI–VIII. Spindle-whorls from Levels 15 to 1

43. Arecanut-shaped; medium depression on top; flat grooves around body.

Ø 2.5 cm. H. 2.0 cm. Colour: black. No. So III A 805.

FS. 0.5–6.5/Cc 5.0–7.0, H. 23.60–23.30 m. Gupta. L.15/14

Note: 7 further specimens of same type from Period VI registered under So III A. Diameter between 2.3 and 3.5 cm.

44. Arecanut-shaped; narrow depression on top; doubly chamfered neck; grooves around body.

Ø 3.0 cm. H. 2.3 cm. Colour: brown. No. So III A 571.

FS. 2 IV 0.5–2.3/Ca 16.0–19.5, H. 24.45–24.15 m. Gupta. L.15

Note: 3 further specimens registered under So III A. Diameter between 2.7 and 3.5 cm.

45. Arecanut-shaped; large depression on top; chamfered neck; prominent groove below shoulder.

Ø 3.6 cm. H. 2.2 cm. Colour: light brown. No. So III A 610.

FS. 2 V 0.5–9.5/Cb 4.0–6.0, H. 24.35–24.05 m. Gupta. L.14

Note: 9 more specimens of same type from Period VI registered under So III A. Diameter between 2.3 and 4.0 cm.

46. Arecanut-shaped; narrow depression on top; slightly chamfered neck; sharp prominent groove on shoulder.

Ø 2.9 cm. H. 2.0 cm. Colour: grey. No. So III A 546.

FS. 2 IV 10.5–13.5/Be 19.5–Ca 1.0, H. 25.50–25.00 m.

Gupta. L.15

Note: 3 more specimen of same type from Periods VI/VII registered under So III A. Diameter between 2.8 and 3.0 cm

47. Arecanut-shaped; large and flat depression on top with two encircling grooves on edge; body completely grooved.

Ø 3.0 cm. Colour: black. No. So III A 556.

FS. 2 IV 6.0–9.5/Ca 10.5–14.5. H. 24.80–24.40 m.

Gupta. L.15/14

Note: 2 more specimens of same type from Period VI registered under So III A 573; 612. Diameter 2.5 and 2.7 cm.

48. Pear-shaped; concave base.

Ø 2.9 cm. H. 3.6 cm. Colour: red. No. So III A 941.

FS. 2 V 0.5–2.0/Cb 19.5–Cc 0.5, H. 24.00–23.70 m.

Gupta. L.15

Note: One more pear-shaped specimen from Period VII registered under So III A 425. Diameter 2.0 cm, Ht. 1.8 cm (damaged).

49. Irregularly spherical; crudely modelled.

Ø 2.3 cm. Colour: red. No. So III A 502.

FS. 2 V 6.4–9.5/Ca 6.5–9.5, H. 24.60–23.75 m.

Gupta. L.15/14

50. Vase-shaped; circular; rounded collar.

Ø 3.0 cm. H. 2.3 cm. Colour: brown. No. So III A 870.

FS. 2 III 19.5–2 IV 0.5/Cb 8.5–12.0, H. 24.30–24.00 m.

Gupta. L.15

Note: One more specimen under So III A 396. Diameter 2.5 cm.

51. Truncated vase-shaped; semicircularly rounded collar mildly under-cut at the neck.

Ø 2.1 cm. H. 1.7 cm. Colour: red. No. So III A 457.

FS. 2 III 19.5–2 IV 0.5/Ca 10.5–19.5, H. 26.50–26.20 m.

Late Medieval. L.8/7

52. Vase-shaped; circular; flattened high collar.

Ø 2.3 cm. Colour: red. No. So III A 188.

FS. 2 IV 14.5–19.5/Ca 3.0–6.0, H. 26.20–25.80 m.

Jāt. L.8/6

53. Vase-shaped; squattish with thick collar and bevelled top.

Ø 2.0 cm. H. 1.2 cm. Colour: brown. No. So III A 204.

FS. 2 IV 18.0–19.5/Ca 4.0–6.0, H. 26.30–26.00 m.

Jāt. L.6

54. Vase-shaped; elongated body; rounded collar.

Ø 3.1 cm. H. 2.7 cm. Colour: red. No. So III A 101.

FS. 2 IV 4.0–6.0/Cb 0.5–5.0, H. 27.40 m. ca. L.5

7

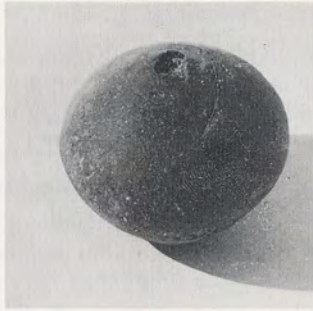

1



2



3



4



5



6

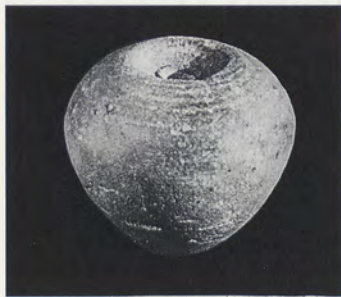

7



8



9



10



11

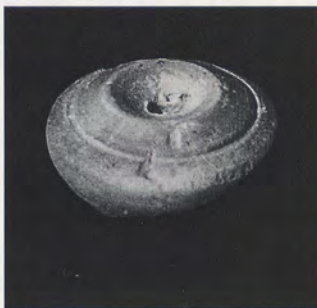

12

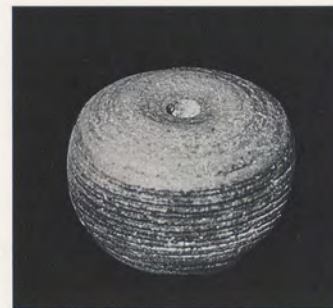

13



14



15



16

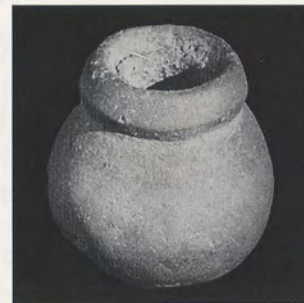

17



18



19



20



21



22

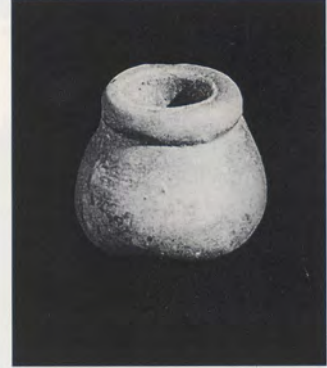

23



24

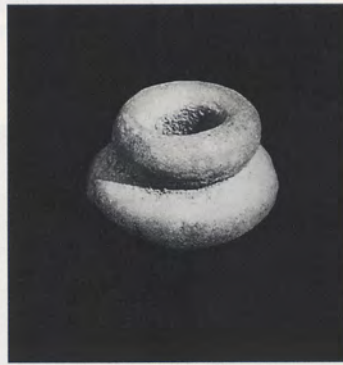

25



26



27



28



29



30



31



32



33



34



35

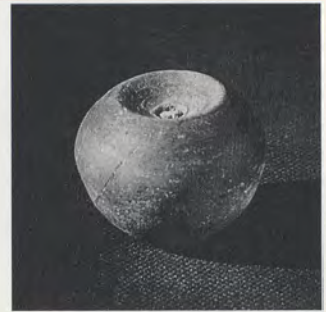

36



37



38



39



40



41



42



43



44



45



46



47



48



49



50



51



52

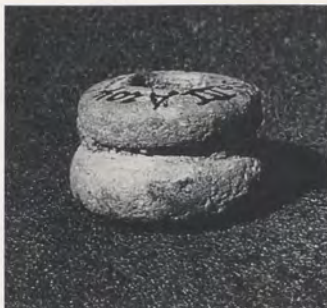

53



54

Terracotta Spindle-whorls. Period VI-VII

Skin-rubbers

Terracotta skin-rubbers have been found in the levels of the Periods II to V, proving that they were in use at least from the Mauryas to the Kuṣāṇas. The rubbers consist, as a rule, of a rectangular or round piece of clay studded with stones or roughened by grooves or holes on one of the sides. All pieces are well fired. In all 86 skin-rubbers or fragments of such have been found in the excavation. They differ in shape and fabric from period to period and can, therefore, be classified as follows.

- A. In Period II three types of skin-rubbers appear:
- oblong with superficially studded chips of sharp and angular stones (no. 1);
 - rectangular with deeply studded small chips of stones (no. 2);
 - rectangular or oval, studded with few chips of stones only and roughened by irregular incisions (nos. 3–4);
- B. In Periods III/IV seven types can be distinguished:
- rectangular or square, similar A.b);
 - rectangular with deeply studded small chips of stones and impressed notches at the long sides for handling the rubber (no. 7)
 - rectangular with closely studded pebbles (no. 8);
 - like c) but with notches at the long sides (no. 9);
 - rectangular and similar to c) but with honeycombed surface (no. 10);
 - like e) but with notches for handling the object (no. 11);
 - round with punctured or criss-cross incised surface (no. 12–13);
- C. In Period V five specimens can be traced:
- continuation of type B.b);
 - rectangular or irregularly shaped with honeycombed surface (no. 16);
 - round with closely studded pebbles (most common type, no. 17);
 - round with honeycombed surface (no. 18);
 - singular pieces with deeply grooved lines (nos. 19–21).

Of all the specimens, the most characteristic are the oblong rubbers with superficially studded sharp and angular stones (A.a) which do not appear any longer after Level 26, and the round varieties which seem to be a special Kuṣāṇa product. The pebble-studded and densely porous rubbers firstly appear in the Mitra levels and change into the round shape in the Kuṣāṇa period. There are no finds of skin-rubbers from later periods.

Period II. Skin-rubbers from Levels 34 to 30

- Fragment of an oblong rubber with superficially studded chips of sharp and angular stones.
10.7 × 6.1 × 5.2 cm. Colour: dull red. No. So III A 3688.
FS. 2 IV 7.1/Cc 2.23, H. 15.38 m. Maurya. L.34/33
Note: 6 more fragments of same type from Period II registered under So III A 2178; 2664; 3188; 3544; 3552; 3684.
- Rectangular skin-rubber with slightly incurved long sides. Deeply studded small chips of stone irregularly spread over the whole surface.
12.9 × 8.2 × 2.2 cm. Colour: dull red. No. So III A 3023.
FS. 2 IV 3.6–10.15/Be 13.6–17.3, H. 18.38–18.22 m.
Late Maurya/Early Śuṅga C.P., L.31
Note: 2 more fragments of same type registered under So III A 3646; 3687.

- Rectangular skin-rubber with few chips of stone studded in the surface roughened by irregular incisions.
8.4 × 5.5 × 1.5 cm. Colour: dull red. No. So III A 2465.
FS. 3 I 6.0–7.0/Ca 11.2–14.5, H. 16.92–16.80 m.
Late Maurya/Early Śuṅga C.P., L.31/30
Note: One more specimen registered as So III A 3078.
- Oval skin-rubber with few chips of stone and roughened surface.
L.8.5 cm. B.4.6 cm. Colour: dull red. No. So III A 3430.
FS.2 IV 13.5/Cc 0.5, H. 16.30 m. Late Maurya. L.32/31

Period III–IV. Skin-rubbers from Levels 28 to 24

- Rectangular rubber with chips of stones studded in the surface. Crudely made.
9.5 × 6.5 × 2.4 cm. Colour: dull red. No. So III A 2968.
FS. 2 IV 3.2–4.6/Be 13.5–16.0, H. 19.44–19.28 m.
Early Mitra. L.28/27
- Square rubber with densely studded chips of small stones in the surface.
8.4 × 7.5 × 2.2 cm. Colour: dull red. No. So III A 3024.
FS.2 V 17.2–3 I 0.5/Cb 7.0–9.5, H. 18.35–18.15 m. Mitra. L.27
Note: Further 5 specimens of same type from Periods III/IV registered under So III A 2550; 2987; 3675; 3683; 3685.
- Rectangular skin-rubber with impressed notches in the long sides for handling the object.
9.4 × 7.5 × 2.0 cm. Colour: dull red. No. So III A 2931.
FS.3 I 0.0–2.2/Ca 19.3–Cb 0.7, H. 18.88–18.78 m. Mitra. L.26
Note: 12 more specimens of same type from Periods III/IV registered under So III A 1536; 1965; 1968; 2349; 2350; 2363; 2629; 2920; 2921; 3102; 3470; 3653.
- Rectangular skin-rubber with slightly incurved long sides studded closely with pebbles.
9.1 × 7.1 × 1.9 cm. Colour: dull red. No. So III A 3017.
FS. 3 I 0.5–2.9/Cb 4.0–4.6, H. 18.05–17.90 m. Mitra. L.27
Note: 4 more specimens of same type from Periods III/IV registered under So III A 2318; 2792; 2795; 3610.
- Rectangular skin-rubber with impressed notches in the long sides for handling the piece. Studded closely with pebbles.
9.3 × 7.8 × 1.7 cm. Colour: dull red. No. So III A 3075.
FS.2 V 10.5–14.5/Cb 0.9–1.5, H. 18.45–18.25 m. Mitra. L.27/26
Note: 2 more rubbers of same type from Period III registered under So III A 2174; 2335.
- Rectangular rubber with honeycombed surface without pebbles.
9.0 × 6.9 × 1.6 cm. Dull red. No. So III A 3431.
FS. 2 V 7.0–9.5/Cc 0.5–1.6, H. 19.15–18.85 m.
Early Kṣatrapa. L.24
Note: 2 more specimens of same type from Period III/IV registered under So III A 2068; 3432.
- Rectangular rubber with impressed notches for handling in the long sides. Honeycombed surface without pebbles.
9.5 × 8.0 × 1.5 cm. Colour: dull red. No. So III A 2043.
FS. 3 I 2.0/Ca 18.3, H. 18.70 m. From well. Mitra. L.26
Note: Further 2 specimens from Period III registered under So III A 2193; 3124.
- Round, crudely made skin-rubber with closely punctured holes on the one and one circle of holes around the edge on the other side.

Ø 7.7 cm. Colour: grey. No. So III A 2310.
FS. 2 V 11.0–16.7/Ca 15.4–19.5, H. 19.60–19.40 m.
Late Mitra/Early Kṣatrapa. L.25/24

13. Round, crudely made skin-rubber with incised criss-cross pattern and a constricting line around and below edge.
Ø 7.8 cm. Colour: dull red. No. So III A 3061.
FS. 2 V 9.9/Cb 7.2, H. 18.90 m. Late Mitra. L.25

Period V. Skin-rubbers from Levels 21 to 17

14. Rectangular rubber similar to no.7 with impressed notches in the long sides for handling the piece.
10.3 × 6.8 cm. Colour: dull red. No. So III A 2095.
FS. 3 I 2.5/Cb 9.5, H. 19.37 m. Kuṣāṇa. L.19
Note: One more specimen registered under So III A 2435.

15. Rectangular skin-rubber with honeycombed surface on one side.
9.8 × 6.8 × 2.2 cm. Colour: dull red. No. So III A 2057.
FS. 2 III 19.8–2 IV 1.5/Be 19.3–Ca 0.5, H. 22.83–22.33 m.
Kuṣāṇa. L.20/19
Note: One more specimen registered under So III A 2816.

16. Irregularly oblong skin-rubber with honeycombed surface on one side.
L. 10.9 cm. Colour: dull red. No. So III A 2040.
FS. 2 IV 9.5–10.5/Be 15.5–19.5, H. 23.49–23.19 m.
Kuṣāṇa. L.17

17. Round skin-rubber studded closely with pebbles.
Ø 9.5 cm. Colour: light brown. No. So III A 1062.
FS. 2 V 15.7/Cb 0.4, H. 23.25 m. Kuṣāṇa. L.17
Note: 7 more round rubbers with pebbles from Period V registered under So III A 579; 703; 736; 826; 925; 1157; 1176.

18. Round skin-rubber with honeycombed surface.
Ø 9.5 cm. Colour: dull red. No. So III A 2096.
FS. 2 V 12.0–13.5/Cb 10.5–19.5, H. 21.40–21.10 m.
Kuṣāṇa. L.21/20
Note: One more honeycombed round rubber registered under So III A 515.

19. Fragmentary rectangular skin-rubber roughened by grooved parallel lines.
8.8 × 6.0 cm. Colour: dull red. No. So III A 1609.
FS. 2 IV 5.0–6.5/Ca 2.8–4.5, H. 23.06–22.55 m.
Kuṣāṇa. L.19/18

20. Mutilated rectangular skin-rubber roughened by grooved parallel lines on the one and 16 irregularly distributed holes on the other side.
8.7 × 6.0 cm. Colour: dull red. No. So III A 1366.
FS. 2 V 7.5–9.5/Ca 1.0–6.5, H. 21.65–21.35 m.
Kuṣāṇa. L.21

21. Mutilated rectangular skin-rubber roughened by grooved criss-cross lines.
6.6 × 4.7 × 1.8 cm. Colour: grey. No. So III A 1351.
FS. 3 I 1.5/Ca 17.0, H. 21.32 m. Kuṣāṇa. L.21

8



1



2



3



4



5



6



7



8



9



10

Terracotta Skin-rubbers. Period II (1-4), Period III-IV (5-10)



11



12



13



14



15

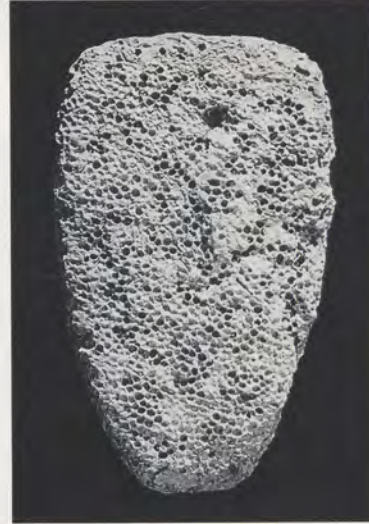

16



17



18



19



20a



20b



21

Terracotta Skin-rubbers. Period III-IV (11-12), Period V (14-21)

Dabbers

In all 82 complete and fragmentary terracotta dabbers have been recovered in the excavation. Their occurrence begins with the Mitras (L.26) and ends in the early medieval times (L.12). The shapes are very divergent and it is nearly impossible to categorize them. They will, therefore, be described and depicted by means of 22 dabbers selected according to their occurrence in the successive levels.

Period III–IV. Dabbers from Levels 26 to 22

1. Fragment of a dabber with mildly chamfered neck and knobbed handle. Scratches on fracture-line perhaps remains of akṣaras.

Ø 7.3 cm. H. 7.8 cm. Colour: grey. No. So III A 3189.
FS. 2 V 19.0–3 I 2.0/Cb 10.5–12.0, H. 18.95–18.80 m.
Mitra. L.26

2. Dabber having flat base, constricted neck and knobbed handle. Scratches on body presumably remains of numbering, but not of inscription.

Ø 11.6 cm. H. 9.7 cm. Colour: dull red. No. So III A 3117.
FS. 2 V 3.5/Cb 9.8, H. 19.10 m. Mitra. L.26/25
Note: One more specimen registered under So III A 3027.

3. Dabber with conical body and slightly curved base. Flattish handle. Vertical strokes incised around body (no inscription).

Ø 8.0 cm. H. 6.6 cm. Brown wash. No. So III A 2118.
FS. 3 I 0.0–2.3/Ca 19.9-Cb 2.6, H. 20.82–20.52 m.
Late Kṣatrapa. L.23/22

4. Small dabber with slim body, flat base, knobbed handle. Cross scratched on top.

Ø 4.8 cm. H. 5.6 cm. Brown wash. No. So III A 3162.
FS. 2 IV 10.9–15.2/Ca 6.5–9.5, H. 20.90–20.55 m.
Early Kuṣāṇa. L.22

Period V–VI. Dabbers from Levels 22 to 12

5. Dabber with conical body and flat base. Knobbed handle with slightly drooping edge.

Ht. 8.6 cm. Colour: red wash. No. So III A 1769.
FS. 2 V 2.1–3.5/Cb 11.9–15.3, H. 21.32–20.90 m.
Early Kuṣāṇa. L.22/21

Note: One more specimen registered under So III A 1122.

6. Big bag-shaped dabber with rounded base, chamfered neck and knobbed handle.

Ø 15.3 cm. Ht. 12.0 cm. Brown wash. No. So III A 2182.
FS. 2 V 6.5–8.0/Ca 17.7–19.5, H. 20.94–20.68 m.
Early Kuṣāṇa. L.22

Note: One more specimen registered under So III A 486.

7. Dabber with rounded base, low body, high neck and knobbed handle.

Ht. 5.4 cm. Colour: brown. No. So III A 1641.
FS. 3 I 4.0–5.5/Ca 10.5–15.0, H. 21.24–20.85 m.
Early Kuṣāṇa. L.22/21

8. Dabber with high conical body, rounded base, constricted neck and flatly knobbed handle. Vertical strokes incised on body.

Ø 9.6 cm. Ht. 8.0 cm. Colour: red. No. So III A 2123.
FS. 2 V 8.0–9.5/Ca 4.3–6.7, H. 21.17–20.87 m.
Kuṣāṇa. L.21

Note: 2 more dabbers of same type registered under So III A 942; 981.

9. Dabber shaped like a mushroom with rounded sides and knobbed handle with drooping edge.

Ht. 7.1 cm. Colour: dull red. No. So III A 1948.
FS. 2 V 10.5–15.1/Cb 14.0–15.5, H. 21.65–21.30 m.
Kuṣāṇa. L.21

Note: 3 more pieces under So III A 1949; 2066; 3160.
Ht. 6.5/7.7 cm.

10. Dabber with elongated body, rounded base, small knobbed handle.

Ø 9.7 cm. H. 8.5 cm. Colour: dull red. No. So III A 2073.
FS. 2 V 7.6–9.5/Ca 19.85-Cb 0.5, H. 22.17–21.82 m.
Kuṣāṇa. L.20

11. Dabber with low body, flattish knobbed handle and incised rosette on top.

Ø 6.0 cm. H. 6.5 cm. Colour: dull red. No. So III A 896.
FS. 2 V 15.5–16.5/Cb 8.0–9.5, H. 22.20–21.90 m.
Kuṣāṇa. L.20

Note: One more specimen but without rosette registered under So III A 1905.

12. Mutilated dabber with rounded sides, constricted neck and voluminous knobbed handle of irregular shape.

Ø 6.2 cm. H. 6.2 cm. Brown wash. No. So III A 2697.
FS. 2 IV 6.4–8.1/Cb 3.8–4.2, H. 22.25–21.95 m.
Kuṣāṇa. L.19

Note: Further 2 specimens registered under So III A 1035; 2883.

13. Mushroom-shaped dabber with wide neck and knobbed handle covering the body.

Ø 7.5 cm. H. 6.5 cm. Red wash. No. So III A 2028.
FS. 2 IV 2.5–9.5/Cb 1.0–2.3, H. 23.26–22.80 m.
Kuṣāṇa. L.17/16

14. Big dabber with conical body, rounded base, constricted neck and thick knobbed handle with depression in the centre.

Ø 10.2 cm. H. 8.9 cm. Colour: grey. No. So III A 1162.
FS. 2 IV 2.3/Ca 9.5, H. 23.10 m. Kuṣāṇa. L.17
Note: One more specimen registered under So III A 1069.

15. Dabber with low conical body, constricted neck and overhanging knobbed handle. Deep hole in centre of knob for inserting a rod.

Ø 6.7 cm. H. 5.2 cm. Dull red. No. So III A 1015.
FS. 2 V 7.5–10.0/Ca 19.5-Cb 0.5, H. 23.62–23.22 m.
Late Kuṣāṇa. L.16

16. Dabber with conical body, constricted neck and overhanging knobbed handle. Deep hole in centre of knob. Incised oblique strokes on the shoulder.

Ø 7.5 cm. H. 6.0 cm. Colour: brown. No. So III A 711.
FS. 2 IV 5.2–8.0/Be 16.7–19.5, H. 24.20–23.70 m.
Kuṣāṇa. L.17/16

17. Fragment of a dabber with low body and knobbed handle. Large deep hole in the centre of the knob.

Ø 7.3 cm. H. 5.5 cm. Dull red. No. So III A 913.
FS. 2 IV 0.5–9.5/Cb 17.5–19.5, H. 23.40–23.15 m.
Late Kuṣāṇa. L. 17/16

18. Dabber with elongated body and narrow, thick knobbed handle. Deep hole in the centre of the knob.

Ø 7.0 cm. H. 6.6 cm. Brown wash. No. So III A 619.
FS. 2 IV 0.5–2.5/Ca 17.5–19.5, H. 24.10–23.80 m.
Late Kuṣāṇa. L.16/15



1



2



3



4



5



6



7

Terracotta Dabbers. Period III-IV (1-4), Period V-VI (5-6)

Terracotta Dabbers. Period V-VI



8



9



10

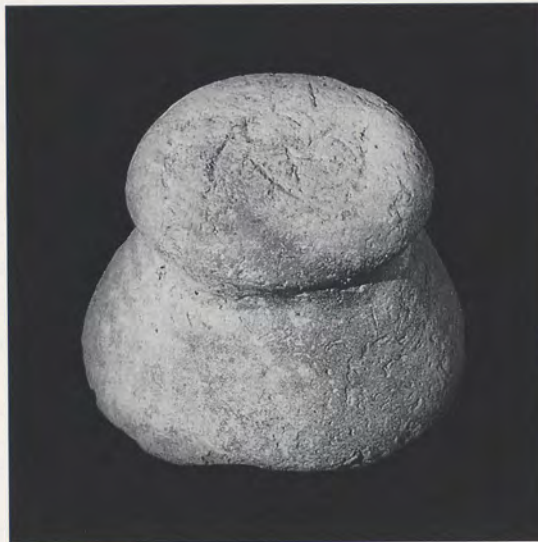

11



12



13



14



15



16



17



18

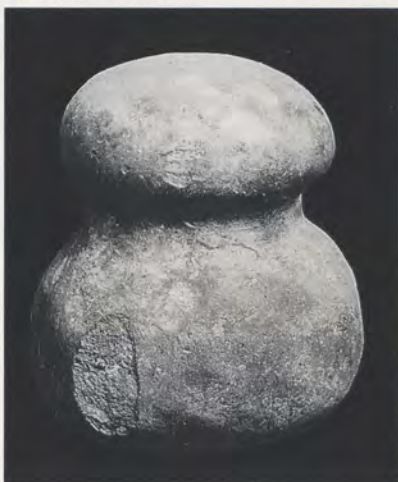

19



20



21



22

19. Dabber having rounded body, high neck and thick knobbed handle with rounded top.

Ø 7.3cm. H. 8.0cm. Colour: dull red. No. So III A 629.

FS.2 V 2.5–5.5/Cb 2.5–4.0, H. 23.90–23.60m. Gupta. L.15

20. Big dabber having low body, rounded base and voluminous knobbed handle. Deep narrow hole in the centre of the knob.

Ø 10.0cm. H. 8.5cm. Red wash. No. So III A 738.

FS. 2 IV 4.5–8.0/Cb 2.0–7.0, H. 24.30–23.95m.

Gupta. L.14

Note: 2 more specimens of same type under So III A 343; 726.

21. Dabber having voluminous body, narrow neck and small knobbed handle.

Ø 7.0cm. H. 6.0cm. Dull red. No. So III A 431.

FS. 2 V 0.5–9.5/Ca 12.5–13.9, H. 24.75–24.50m.

Late Gupta. L.14/13

22. Dabber having rounded body, flat base, constricted neck and massive knobbed handle.

Ø 7.5cm. H. 5.8cm. Dull red. No. So III A 343a.

FS. 2 IV 6.0–8.0/Ca 17.5–19.5, H. 24.90–24.60m.

Medieval. L.12

Reels

During the course of excavation 43 terracotta reels have been found from the levels of the Maurya to the Kuṣāṇa times with a concentration in the Kṣatrapa levels, where alone 26 pieces, i.e. more than half of the whole amount, came to light. Shape and size vary considerably. All the reels are of grey colour, sometimes black-slipped. The main types will be recorded here according to their appearance in the successive levels.

Period II–III. Reels from Levels 32 to 26

1. Plain reel; short concave; both sides rounded surface.

Ø 4.0cm. H. 2.3cm. Colour: grey. No. So III A 3622.

FS. 2 IV 15.0–16.8/Cc 8.5–9.5, H. 16.00–15.30m.

Maurya. L.32

Note: One more reel from L.33 registered under So III A 3499.

2. Plain reel; short concave; both sides flat surface.

Ø 2.9cm. H. 1.9cm. Colour: grey. No. So III A 2579.

FS. 3 I 6.3–7.5/Ca 11.5–17.6, H. 16.45–16.35m.

Maurya. L.32

Note: One more specimen from L.29 registered under So III A 3577

3. Plain reel; standard concave; flat surface both sides.

Ø 2.3cm. H. 2.3cm. Colour: grey. No. So III A 3472.

FS. 2 IV 0.5–4.0/Cc 0.5–3.5, H. 16.90–16.75m.

Early Mitra. L.29

Note: One more specimen from L.33 registered under So III A 2591

4. Reel; short concave; concentric rings on both sides and body.

Ø 2.3cm. H. 1.3cm. Colour: grey. No. So III A 3029.

FS. 2 V 8.35–10.5/Ca 9.5–10.4, H. 18.64–18.08m.

Mitra. L.27/26

Period IV–V. Reels from Levels 24 to 17

5. Plain reel; long concave; flat ends.

Ø 2.2cm. H. 3.4cm. Colour: grey. No. So III A 3187.

FS. 2 IV 12.7–14.0/Cc 0.5–9.5, H. 18.90–18.75m.

Early Kṣatrapa. L.24

Note: 3 more specimens of Period IV registered under So III A 2187; 2315; 2505.

6. Plain reel; long concave; rounded ends.

Ø 2.4cm. H. 3.8cm. Colour: grey. No. So III A 2663.

FS. 2 V 16.4–17.4/Cc 3.0–6.5, H. 19.18–18.93m.

Early Kṣatrapa. L.24

7. Mutilated reel; long concave; concentric rings on both ends.

Ø 2.1cm. H. 3.5cm. Colour: grey. No. So III A 1874.

FS. 2 V 17.0–19.0/Ca 4.5–9.5, H. 20.04–19.80m.

Kṣatrapa. L.23

8. Mutilated reel; standard concave; concentric rings on both shallow ends.

Ø 2.2cm. H. 1.7cm. Grey, black-slipped. No. So III A 3198.

FS. 2 IV 10.5–12.7/Cc 0.5–1.1, H. 18.90–18.75m.

Early Kṣatrapa. L.24

Note: One more specimen from L.23 registered under So III A 2711

9. Mutilated reel; short concave; concentric rings on both flat ends.

Ø 1.95cm. H. 1.43cm. Colour: grey. No. So III A 1758.

FS. 2 V 16.0–17.0/Ca 4.0–9.5, H. 20.04–19.80m.

Kṣatrapa. L.23

Note: 3 more specimens from L.23 registered under So III A 2469; 2503; 2733.

10. Exquisitely modelled reel; short concave; concentric rings on both flat ends.

Ø 2.0cm. H. 1.6cm. Grey, black-slipped. No. So III A 2675.

FS. 2 V 1.1/Cb 4.0, H. 19.65m. Kṣatrapa. L.23

Note: 3 more specimens of same type from L.24/23 registered under So III A 2364; 2777; 3127.

11. Reel; short concave; concentric rings on both flat sides.

Ø 1.9cm. H. 1.3cm. Colour: grey. No. So III A 3149.

FS. 2 IV 16.0–17.25/Cc 0.5–9.5, H. 19.20–19.05m.

Kṣatrapa. L.24/23

Note: 8 more specimens of same type from L.24–22 registered under So III A 2157; 2179; 2401; 2504; 2613; 2865; 3062; 3140.

12. Broad reel; short concave; concentric rings on both flat ends.

Ø 3.1cm. H. 1.3cm. Colour: grey. No. So III A 2863.

FS. 2 IV 16.5–2 V 0.5/Ca 6.8–9.5, H. 21.80–21.60m.

Kuṣāṇa. L.21

Note: One more specimen from L.20/19 registered under So III A 1309.

13. Mutilated reel; short concave; concentric rings on both nearly flat ends.

Ø 2.3cm. H. 1.1cm. Grey, black-slipped. So III A 2036.

FS. 2 IV 1.5–9.5/Be 19.5–Ca 0.5, H. 23.15–22.85m.

Kuṣāṇa. L.18/17



1



2



3



4



5



6



7



8



9



10



11



12



13

Terracotta Reels. Period II-III (1-4), Period IV-V (5-13)

Game Pieces

Exactly 100 terracotta pieces which can be classified as game pieces (gamesmen and dice) have been found at Sonkh. The earliest finds hail from the Mauryan Levels 34/33, the latest from the late medieval Levels 8/7. In Period II exclusively geometrical shapes came to light, i.e. the forms of short cylinder and short/standard/long truncated cone. Here as well as in later geometric pieces it is a conspicuous fact that most of them show a shallow depression on top, perhaps for placing the forefinger in it.

In Period III to IV the geometrical shapes continue, but with no. 13 and 14 the first deviations from the standard types can be recognized. To the end of Period IV, i.e. to the early Kṣātrapa Level 24, belongs a longish terracotta dice with incised marks for the numbers 1 to 4, similar to those made of bone.

The Kuṣāṇa Period V carries on with shapes of short and long cylinder and introduces the untruncated long cone, but soon now completely new shapes prevail over the standards (nos. 20 to 26). Different are the finds from the later Periods VI to VIII where the pyramidal shapes seem to have been favoured.

Period II. Game pieces from Levels 34 to 32

1. Mutilated gamesman; short cylinder; uncertain number of shallow holes on top.

Ø 5.9 cm. H. 3.6 cm. Colour: dull red. No. So III A 2597.
FS. 3 I 11.8–12.45/Ca 18.3–18.9, H. 12.25–11.65 m. Pit.
Maurya. L.34/33

2. Gamesman; short cylinder.

Ø 2.6 cm. H. 1.6 cm. Colour: grey. No. So III A 1971.
FS. 3 I 10.8–11.9/Ca 16.3–17.5, H. 14.20–13.70 m.
Well no. 2. Maurya. L.34

3. Gamesman; short truncated cone; on top indefinite incision.

Ø 3.0 cm. H. 1.9 cm. Dull red. No. So III A 241.
FS. 2 IV 15.5–17.9/Cc 7.5–9.5, H. 15.82–15.55 m.
Maurya. L.33

Note: One more specimen from L.33 registered under So III A 3421

4. Gamesman; long truncated cone; depression on top (with strokes radiating from centre?).

Ø 2.8 cm. H. 5.1 cm. Colour: grey. No. So III A 2553.
FS. 3 I 4.2–7.5/Ca 6.8–9.0, H. 16.78–16.60 m.
Maurya. L.32

Note: One more specimen of same type from L.34 registered under So III A 1997. Ht. 6.2 cm.

5. Gamesman; standard truncated cone; shallow depression on top.

Ø 2.1 cm. H. 2.7 cm. Colour: grey. No. So III A 3434.
FS. 2 IV 16.8–18.1/Cc 4.5–8.4, H. 15.85–15.70 m.
Maurya. L.33/32

Note: 13 more specimens of same type from Period II registered under So III A. Height between 2.5 and 4.0 cm.

6. Gamesman; standard truncated cone; depression on top.

Ø 3.0 cm. H. 4.1 cm. Colour: grey. No. So III A 2468.
FS. 3 I 6.8/Ca 15.0, H. 16.75 m. Maurya. L.32

Note: 6 more specimens from Period II registered under So III A. Height between 3.2 and 4.3 cm.

7. Gamesman; long truncated cone; depression on top.

Ø 2.2 cm. H. 5.4 cm. Dull red. No. So III A 3498.
FS. 2 IV 15.8–18.1/Cc 0.5–3.6, H. 15.90–15.50 m.
Maurya. L.33

Period III–IV. Game pieces from Levels 28 to 24

8. Gamesman; short truncated cone; depression on top.

Ø 2.1 cm. H. 1.8 cm. Colour: grey. No. So III A 3340.
FS. 2 IV 15.6–18.3/Cc 6.0–9.5, H. 17.35–17.05 m.
Early Mitra. L.28

Note: 7 more specimens of same type from Periods III/IV registered under So III A. Height between 1.9 and 2.6 cm.

9. Gamesman; short cylinder with one concave end; rectangle of punched holes on top.

Ø 2.5 cm. H. 0.8 cm. Colour: grey. No. So III A 3101.
FS. 2 V 18.0/Cb 4.2, H. 18.25 m. Mitra. L.27

10. Gamesman; short cylinder; shallow depression on top.

Ø 2.2 cm. H. 1.2 cm. Colour: brown. No. So III A 2934.
FS. 2 V 19.5–3 I 0.4/Cb 0.0–3.5, H. 18.77–18.60 m.
Mitra. L.26/25

Note: 2 more specimens of same type from Period III registered under So III A 2120; 2347. Height between 1.4 and 1.5 cm.

11. Gamesman; long truncated cone; depression on top.

Ø 1.9 cm. H. 4.8 cm. Colour: grey. No. So III A 3680.
FS. 2 III 16.2–18.1/Cc 7.15–9.45, H. 18.60–18.50 m.
Mitra. L.26

Note: 8 more specimens registered under So III A. Height between 3.5 and 4.9 cm.

12. Gamesman; standard cylinder; slight depression on top.

Ø 1.8 cm. H. 3.1 cm. Colour: grey. No. So III A 2902.
FS. 2 V 13.0–18.4/Cc 0.5–1.8, H. 19.15–19.00 m.
Early Kṣātrapa. L.24

Note: 2 more pieces of same type registered under So III A 2289; 2432.

13. Gamesman on stand; body shaped like vessel with two-stepped lid; perforation through body.

Ø 1.6 cm. H. 2.3 cm. Black-slipped. No. So III A 2910.
FS. 2 V 4.5/Ca 11.8, H. 18.95 m. Mitra. L.26

Note: Safe find-spot although piece would better fit the development of gamesmen in periods IV/V.

14. Defaced gamesman; conical stand; pot-shaped handle.

Ø 2.6 cm. H. 4.1 cm. Colour: grey. No. So III A 3217.
FS. 2 V 19.5–3 I 2.0/Cc 3.0–9.5, H. 19.22–19.05 m.
Early Kṣātrapa. L.24

15. Longish dice of terracotta with markings for 1 to 4 by incision of circles with central dot. Crudely made.

L.5.0 cm. H. 1.25 cm. Colour: grey. No. So I 352.
FS. 2 V 6.0/Cb 14.3, H. 19.00 m. Early Kṣātrapa. L.24

Period V. Game pieces from Levels 21 to 16

16. Gamesman; short cylinder with shallow depression on top, giving the piece the appearance of a tiny bowl.

Ø 2.3 cm. H. 1.2 cm. Colour: grey. No. So III A 1891.
FS. 2 V 7.0–9.5/Cc 0.5–9.5, H. 21.70–21.40 m.
Kuṣāṇa. L.20/19

Note: 2 more pieces of same type registered under So III A 1310; 1590.

17. Gamesman (?); short cylinder; flat top.

Ø 3.2 cm. H. 2.6 cm. Colour: dull red. No. So III A 699.
FS. 2 V 10.5–3 I 3.0/Ca 19.4–19.5, H. 23.90–23.30 m.
Late Kuṣāṇa. L.16/15

18. Gamesman; long cylinder; slight depression on top.

Ø 1.6 cm. H. 3.6 cm. Colour: grey. No. So III A 3177.

FS. 2 III 4.5–7.5/Cc 4.0–6.5, H. 21.30–21.10m.

Kuṣāṇa. L. 21/(20)

Note: 4 more fragments from Period V registered under So III A.

19. Gamesman; long cone.

Ø 1.55 cm. H. 3.4 cm. Black-slipped. No. So III A 1324.

FS. 2 V 7.0–9.5/Cc 0.5–9.5, H. 22.37–22.12m.

Late Kuṣāṇa. L.17/16

Note: 2 fragments of same type registered under So III A.

20. Gamesman; flat, nearly square piece with incised marks on obverse consisting of four circles, four strokes and a pointing sign arranged in a distinct position. Back plain and flat.

2.6 × 2.8 × 0.55 cm. Colour: dull red. No. So I 309.

FS. 2 IV 15.7–17.5/Ca 5.5–6.3, H. 21.90–21.60m.

Kuṣāṇa. L.21

21. Mutilated gamesman; shaped like a tiny dish on stand with indented rim.

Ø 1.3 cm. H. 2.1 cm. Colour: grey. No. So III A 2958.

FS. 2 IV 13.0–15.1/Be 17.25–19.9, H. 21.68–21.53m.

Kuṣāṇa. L.21

22. Mutilated gamesman with conical stand and indefinite animal head.

H. 3.0 cm. Colour: black-slipped. No. So III A 2099.

FS. 2 V 15.8/Cc 1.9, H. 21.32m. Kuṣāṇa. L.20

23. Gamesman consisting of a reel-shaped stand with high conical handle on top.

Ø 2.6 cm. H. 2.9 cm. Colour: dull red. No. So III A 848.

FS. 2 V 0.5–3.0/Ca 0.0–5.0, H. 22.30–22.00m.

Kuṣāṇa. L.19

24. Gamesman shaped like a vessel with conical lid.

Ø 2.3 cm. H. 2.0 cm. Black-slipped. No. So III A 877.

FS. 2.5–3.5/Ca 6.0–7.5, H. 22.50–22.30m. Kuṣāṇa. L.18

25. Gamesman with conical stand and mutilated handle, possibly shaped as an animal's head.

Ø 1.9 cm. H. 3.4 cm. Colour: grey. No. So III A 2657.

FS. 2 IV 0.5–9.0/Cb 19.5-Cc 1.8, H. 22.66–22.43m.

Kuṣāṇa. L.17

26. Gamesman in shape of a small cone with rounded base and top.

Ø 1.9 cm. H. 1.6 cm. Colour: red. No. So III A 2038.

FS. 2 III 10.5–19.5/Cb 9.0–9.5, H. 23.57–23.20m.

Late Kuṣāṇa. L.16

Periods VI–VIII. Game pieces from Levels 15 to 7

27. Gamesman; short truncated cone with shallow depression on top.

Ø 3.0 cm. H. 2.0 cm. Dirty grey. No. So III A 570.

FS. 2 IV 11.0–19.5/Ca 19.5-Cb 0.5, H. 24.55–24.25m.

Gupta. L.15

Note: One more specimen of same type from L.15 registered under So III A 553.

28. Gamesman; standard cylinder.

Ø 2.9 cm. H. 3.0 cm. Light brown. No. So III A 859.

FS. 2 IV 10.5–2 V 0.5/Ca 9.5–11.5, H. 24.50–24.00m.

Gupta. L.15

Note: 4 more specimens from periods VI/VII registered in So III A

29. Gamesman; irregularly shaped long cylinder.

H. 4.9 cm. Colour: dull red. No. So III A 336.

FS. 2 IV 2.5–4.3/Ca 14.0–19.5, H. 25.05–24.75m.

Medieval. L.12

30. Gamesman shaped like a lid with conical handle.

Ø 3.6 cm. H. 2.0 cm. Colour: grey. No. So III A 914.

FS. 2 IV 2.0–9.0/Ca 19.5-Cb 0.5, H. 24.40–24.10m.

Gupta. L. 15

31. Gamesman (?) shaped like a short cone with three large impressed finger-holes on top.

Ø 12.3 cm. H. 5.0 cm. Dull red. No. So III A 397.

FS. 2 V 2.7/Ca 0.5, H. 24.30m. Gupta. L.15

32. Gamesman; standard cone; slight impression on top.

Ø 2.2 cm. H. 1.9 cm. Light brown. No. So III A 565.

FS. 2 IV 16.5–19.5/Ca 0.5–4.25, H. 24.90–24.60m.

Late Gupta. L.14/13

33. Gamesman (?); square cube with slightly depressed sides.

1.8 × 2.0 cm. Colour: light brown. No. So III A 1024.

FS. 2 IV 9.5–10.5/Cb 9.5–11.0, H. 25.13–24.63m.

Medieval. L.13/12

34. Gamesman; conical; rounded top with traces of flat knob and an elevated ring above shoulder.

Ø 3.5 cm. H. 2.0 cm. Colour: brown. No. So III A 334.

FS. 2 V 10.5–12.5/Ca 10.5–19.5, H. 25.25–24.95m.

Late Medieval. L.10/9

35. Gamesman; conical with rounded top and grooved lines above and around shoulder and base.

H. 3.1 cm. Colour: dull red. No. So III A 136.

FS. 2 IV 12.5–19.5/Cb 9.0–16.0, H. 26.00–25.60m.

Late Medieval. L.8/7

36. Gamesman (?); flat dish-shaped piece with shallow depression.

Ø 2.8 cm. Colour: dirty brown. No. So III A 231.

FS. 2 IV 0.5–9.5/Ca 17.3–15.5, H. 26.00–25.70m.

Late Medieval. L.8/7



1



2

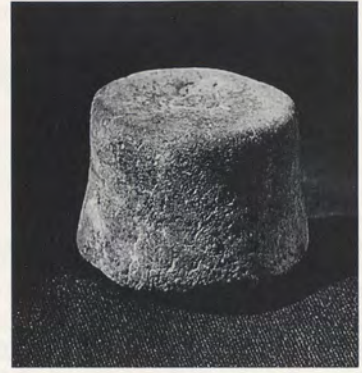

3



4



5



6



7



8



9



10



11



12



13



14



15



16



17



18



19



20



21



22



23



24



25



26



27

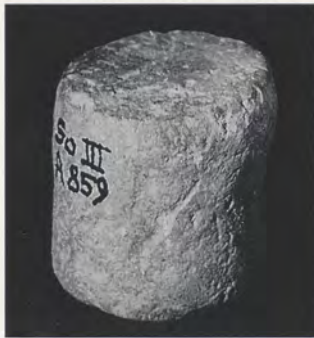

28



29



30



31



32



33



34



35

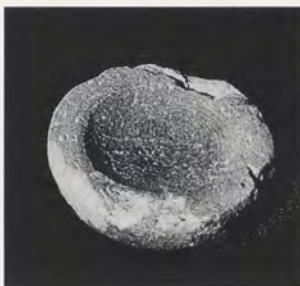

36

Terracotta Gamesmen. Period V (16–26), Period VI–VIII (27–36)

12
Balls

Of all 113 terracotta balls found in the levels of Periods I to VIII 77 are undecorated while 36 show decorations of different kind. The general characteristics of the plain balls remained, naturally, the same throughout the periods. They are of varying quality in modelling but show otherwise no details which could help to categorize them. Their colour is, through all the periods, grey, brown or red, sometimes washed. The diameters vary between 1.2 and 4.8 cm with a concentration on the lower measures, i.e. between 1.2 and 2.8 cm. Because of the similarity of the plain balls only one specimen each of the Periods I/II, III, IV, V, and VI/VIII are illustrated.

Decorated balls occur in all the periods with slight variations. These balls are, like the plain types, of grey, brown or red colour. Sometimes they are rather spheroid than spherical in shape. A selection of the 15 main patterns is presented here.

Plain Balls

1. Irregularly spherical; originally smooth surface; traces of red slip.

Ø 3.77 cm. Colour: red. No. So III A 1886.
FS. 3 II 7.0–8.2/Ca 13.7–19.5, H. 15.31–15.20 m.
PGW. L.37

2. Irregularly spherical; uneven surface.

Ø 1.64 cm. Colour: brown. No. So III A 1455.
FS. 3 II 5.0–8.8/Ca 17.0–19.5, H. 18.05–17.75 m.
Early Mitra. L.28/27

3. Irregularly spherical; uneven surface.

Ø 3.1 cm. Colour: red. No. So III A 1129.
FS. 3 I 6.0–8.5/Ca 12.0–19.5, H. 20.67–20.37 m.
Kṣātrapa. L.23

4. Irregularly spherical; uneven surface.

Ø 1.7 cm. Colour: red. No. So III A 1103.
FS. 3 I 0.2–4.0/Ca 19.5–Cb 0.5, H. 23.40–23.20 m.
Late Kuṣāṇa. L.16

5. Spherical; smooth surface.

Ø 2.3 cm. Colour: grey. No. So III A 91.
FS. 2 IV 10.5–19.5/Ca 12.0–19.5, H. 27.30–26.80 m.
Jāt. L.3

Decorated Balls

6. Spherical; finely modelled; incised lines forming a six-rayed star.

Ø 4.3 cm. Colour: brown. No. So III A 3428.
FS. 2 IV 3.5–4.5/Cc 8.7–9.5, H. 14.50–14.20.
PGW. L.37

7. Spheroid; softly impressed lines dividing the surface in six sectors.

Ø 1.8 cm. Colour: grey. No. So III A 1945.
FS. 3 II 7.0/Ca 19.0, H. 14.40 m. PGW. L.37

8. Irregularly spherical; smooth surface; three impressed crescents.

Ø 2.5 cm. Colour: brown. No. So III A 398.
FS. Trench 4. H. 18.20–18.00 m. Maurya. L.33

9. Spherical; uneven surface; grooved cross.

Ø 1.7 cm. Colour: brown. No. So III A 3041.
FS. 2 V 0.5–2.5/Ca 19.5–Cb 3.2, H. 18.85–18.60 m.
Mitra. L.26

10. Irregularly spherical; punched with numerous holes.

Ø 2.3 cm. Colour: brown wash. No. So III A 3352.
FS. 2 V 10.5–17.0/Cb 15.5–17.0, H. 18.90–18.70 m.
Mitra. L.26

11. Spheroid; mutilated surface; elevated stamped circle with irregularly incised sector lines.

Ø 2.1 cm. Colour: grey. No. So III A 2770.
FS. 2 V 7.1–9.0/Ca 1.5–5.0, H. 19.38–19.10 m.
Mitra. L.26/25

12. Irregularly spherical; stamped circular lines crossing each other.

Ø 2.0 cm. Colour: grey. No. So III A 2749.
FS. 2 V 4.0–6.5/Ca 8.0–9.5, H. 19.38–19.10 m.
Mitra. L.26/25

13. Irregularly spherical; smooth surface; three softly impressed crescents arranged like no. 8.

Ø 2.7 cm. Colour: dull red. No. So III A 2667.
FS. 2 V 5.6–6.3/Cb 1.5–9.7, H. 20.65–19.97 m.
Late Kṣātrapa. L.23/22

14. Spheroid; decorated with eight slightly curved impressed grooves.

Ø 2.8 cm. Colour: dull red. No. So III A 2506.
FS. 2 V 1.0/Cb 0.3, H. 20.45 m. Early Kuṣāṇa. L.22

15. Spheroid; surface divided in six sectors by deeply grooved lines.

Ø 1.9 cm. Colour: dull red. No. So III A 1136.
FS. 3 II 1.0–9.5/Ca 17.3–19.5, H. 20.64–20.34 m.
Early Kuṣāṇa. L.22

16. Irregularly spherical; decorated with crossing lines.

Ø 2.4 cm. Colour: grey. No. So III A 2823.
FS. 2 IV 16.1–18.5/Ca 5.8–9.5, H. 21.95–21.70 m.
Kuṣāṇa. L.(21)/20.

17. Spherical; four holes arranged in a square.

Ø 2.4 cm. Colour: grey. No. So III A 3033.
FS. 2 IV 0.5–5.5/Cb 9.5–10.5, H. 22.00–21.70 m.
Kuṣāṇa. L.20

18. Irregularly spherical; divided in four sectors by punched lines of short notches.

Ø 2.5 cm. Colour: brown. No. So III A 3148.
FS. 2 III 0.7–3.3/Cc 7.7–9.5, H. 21.60–21.30 m.
Kuṣāṇa. L.20

19. Spheroid; decoratively divided in six sectors by grooved lines.

Ø 2.2 cm. Colour: grey. No. So III A 2945.
FS. 2 IV 15.5–17.5/Ca 5.5–7.0, H. 21.55–21.40 m.
Kuṣāṇa. L.21

20. Spheroid; decoratively divided in six sectors by grooved lines.

Ø 2.0 cm. Colour: brown. No. So III A 523.
FS. 2 V 8.5–9.5/Ca 17.7–19.5, H. 23.90–23.60 m.
Gupta. L.15

21. Irregularly spherical; surface divided in four sectors by grooved lines being crossed by one deeply cut line running along the circumference.

Ø 2.1 cm. Colour: brown. No. So III A 263.
FS. 2 IV 2.5–4.8/Be 17.0–19.5, H. 25.46–25.16 m.
Gupta. L.15



1



2



3



4



5



6



7



8



9



10



11



12



13



14



15



16



17

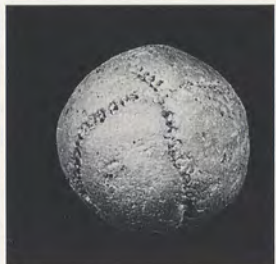

18



19



20



21

Terracotta Balls. Plain (1-5), Decorated (6-21)

Bangles

The number of terracotta bangles amounts to 65 altogether. Due to the fragile material and structure most of them are preserved as small fragments only. They have been found all over the Levels 38 to 21, i.e. in the Periods I to V, with a conspicuous concentration in Period IV. The earliest pieces are either circular or triangular (with rounded corners) in section, the later specimens are shaped as a flattish band. Those of circular section are often undecorated while all the others show varying decorations. Two patterns prevail: 1) the double nodules divided by a central line (no. 6), and 2) the creeper (no. 7). No specimens of terracotta bangles have been found from Periods VI to VIII. The main types are recorded here according to their appearance in the successive levels.

Periods I–V. Bangles from Levels 38 to 21

1. Tiny fragment of a bangle; triangular in section; outer side decorated with incised zigzags.
L. 2.1 cm. Colour: brown. No. So III A 2131.
FS. 3 I 14.0–15.5/Ca 14.75–18.0, H. 14.85–14.75 m.
PGW. L.38
2. Plain bangle; irregularly circular; crudely made.
Ø 5.0/0.6 cm. Colour: brown. No. So I 218.
FS. 3 I 14.0/Ca 16.6, H. 15.60 m.
Early Maurya. L.35/34
Note: 2 more specimens from L.34/33 registered under So III A 205; 1992.
3. Fragment of a bangle; circular in section; impressed short notches on outer side.
L. 5.5 cm. Colour: brown. No. So III A 1963.
FS. 3 I 10.8–11.7/Ca 15.9–17.5, H. 15.86–15.26 m.
Well no. 2. Maurya. L.34
4. Fragment of a bangle; triangular in section; double row of impressed short notches on outer side.
L. 3.9 cm. Colour: brown. No. So III A 3374.
FS. 2 IV 13.4–15.5/Cc 0.5–5.7, H. 16.75–16.60 m.
Ditch from L.30. Śuṅga C.P.
5. Plain bangle; circular section.
Ø 4.3/0.7 cm. Colour: brown. No. So III A 3471.
FS. 2 V 9.5–10.5/Cb 13.5–19.5, H. 18.80–18.65 m.
Mitra. L.25
Note: One more specimen from L.27 under So III A 3218.
6. Fragment of a bangle; flattish rectangular in section; outer side moulded with two rows of nodules between three parallel ridges running along the circumference.
L. 4.3 cm. H. 1.5 cm. Colour: brown. No. So III A 3379.
FS. 2 III 19.5–2 IV 10.5/Cc 0.5–2.5, H. 19.10–18.95 m.
Mitra. L.25
Note: 12 more fragments of same type from Periods III/IV registered under So III A.
7. Fragment of a bangle; flattish rectangular; outer side decorated with moulded herring-bone pattern.
L. 4.8 cm. H. 1.7 cm. Colour: grey. No. So III A 3151.
FS. 2 IV 11.9–13.4/Cc 0.5–5.7, H. 19.20–19.05 m.
Kṣatrapa. L.24/23
Note: 20 more fragments of same pattern from Periods III to V registered under So III A.
8. Fragment of a bangle; flattish rectangular in section; outer side decorated with a moulded long-stretched honeycomb pattern.

L. 2.7 cm. H. 1.3 cm. Colour: brown. No. So III A 1943.
FS. 3 I 0.5–2.5/Ca 9.3–12.8, H. 19.85–19.65 m.
Early Kṣatrapa. L.24

9. Fragment of a bangle; flattish rectangular in section; moulded with a pattern of “pillars” between elevated lines and an adjoining second row of oblique “pillars”, originally bordered by a third edging ridge.

L. 3.1 cm. H. 1.3 cm. Colour: brown. No. So III A 2868.
FS. 2 V 0.5–4.0/Ca 9.5–10.5, H. 20.05–19.70 m.
Kṣatrapa. L.24/23

10. Fragment of a bangle; flattish rectangular; outer side moulded with pattern of alternate oblong fields showing tree, ladder, Andrews’ cross, Andrews’ cross, ladder.

L. 6.2 cm. H. 1.9 cm. Colour: brown. No. So III A 2705.
FS. 2 V 6.5–9.0/Cc 5.0–8.9, H. 19.92–19.62 m.
Late Kṣatrapa. L.23/22.

Note: One more specimen of similar pattern: tree, ladder, Andrews’ cross, ladder, tree, from L.23 registered as So III A 2410.

11. Fragment of a bangle; flattish rectangular in section; moulded with a pattern similar to a tendril but showing irregularly arranged adversifoliate leaves.

L. 4.9 cm. H. 1.8 cm. Colour: brown. No. So III A 3393.
FS. 2 V 5.5–9.6/Cb 18.2–19.3, H. 19.38–19.22 m.
Kṣatrapa. L.23

12. Fragment of a bangle; flattish rectangular in section; moulded with one row of thick nodules between two ridges running along the circumference.

L. 2.7 cm. H. 1.3 cm. Colour: brown. No. So III A 1789.
FS. 2 V 8.0–9.5/Cb 11.5–12.9, H. 21.00–20.60 m.
Early Kuṣāṇa. L.22/21

Amulet and Pendants

One Amulet and twenty-three pendants are recorded from Periods II to VII. The amulet is an outstanding specimen, the shapes of the pendants are best presented by seven selected pieces from the successive levels.

Amulet

1. Moulded hand with a realistically shaped palm, the back of which was left unfinished. A perforation channel runs from the side of the thumb to the side of the little finger, indicating that this piece was carried on a string. The finger-joints are separated by pearl rings. Three symbols are marked on the palm: on the right a Svastika turning left, in the centre a Nandyāvarta, and on the left a sign which is known as Indradhvaja.

H. 3.1 cm. Colour: grey, black-slipped. No. So I 328.
FS. 2 V 9.5/Ca 12.0, H. 18.53–18.35 m. Mitra. L.27

Pendants

2. Long truncated cone; perforation near the top end.
H. 4.5 cm. Colour: grey. No. So III A 2571.
FS. 3 I 6.7–8.5/Ca 13.0–17.0, H. 16.65–16.55 m.
Maurya. L.33

3. Irregular long cone; perforation below top end. H. 5.0cm. Colour: grey. No. So III A 3615. FS. 2 IV 7.7–11.2/Cc 7.5–9.5, H. 16.20–16.08m. Maurya. L.32
4. Long truncated cone; depression on top; perforation near top end. H. 4.0. Colour: grey. No. So III A 3456. FS. 2 IV 15.5–17.0/Cc 0.5–9.5, H. 16.45–16.30m. Śuṅga C.P., L.31
5. Irregular long cone; rounded top; rough perforation near top end. H. 3.75cm. Colour: grey. No. So III A 1413. FS. 3 II 0.2–3.5/Ca 16.9–19.5, H. 18.45–18.10m. Mitra. L.27/26
6. Long truncated cone; depression on top; perforation near top end. H. 2.9cm. Colour: brown. No. So III A 3507. FS. 2 III 10.5–13.0/Cc 6.0–9.5, H. 19.10–18.95m. Mitra. L.25
7. Long truncated cone; perforation near top end. H. 4.0cm. Colour: grey. No. So III A 1628. FS. 2 III 16.0–19.5/Cb 18.0–19.5, H. 22.80–22.50m. Kuṣāṇa. L.18/17
8. Standard cone; perforation near top end. H. 5.2cm. Colour: grey. No. So III A 408. FS. 2 V 5.8–8.0/Cb 0.5–3.5, H. 25.00–24.60m. Late Gupta. L.13

Rattles

27 terracotta rattles and fragments of them and 2 sophisticated hollow plaques used as rattles (nos. 146; 147, chapter Human Terracotta Figurines) have been found from levels of the Periods III (Mitra) to VII (Medieval). Most fragments are of the upper part of rattles, i.e. the handle with part of the body. Eight selected pieces represent the types found at Sonkh.

1. Handle and neck of a rattle having slim body and squarely squeezed top shaped like the parapet of a tower. H. 3.4cm. Colour: grey-brown. No. So III A 2928. FS. 2 V 14.5–17.5/Cb 14.5–19.5, H. 19.00–18.85m. Mitra. L.25
2. Handle and part of neck of a rattle shaped like a half-opened flower. H. 2.8cm. Colour: brown. No. So III A 3567. FS. 2 V 15.0–16.5/Cc 3.0–9.5, H. 18.88–18.65m. Mitra. L.25. *Most common type.*
3. Top and shoulder of a rattle shaped like a bottle. Handle plain and rounded. Traces of decorative incisions. H. 5.7cm. Colour: brown. No. So III A 3596. FS. 2 V 1.5–4.7/Cc 8.0–9.5, H. 18.78–18.55m. Mitra. L.26
4. Handle of a rattle shaped like a half-opened flower with separated petals. H. 6.0cm. Colour: brown. No. So III A 1734. FS. 2 V 4.0–8.0/Ca 7.0–9.5, H. 21.86–21.70m. Kuṣāṇa. L.20

5. Body of a rattle with small hole for inserting pebbles. Handle broken off. H. 6.2cm. Colour: dull red. No. So III A 1885. FS. 3 I 0.5/Cb 6.9, H. 21.30m. Kuṣāṇa. L.21
6. Fragment of a rattle. Handle shaped like a square parapet of a tower (cp. no. 1). Below neck a hole for inserting pebbles. H. 6.4cm. Colour: dull red. No. So III A 1388. FS. 2 IV Cc 3.0–7.5/Cc 2.6–4.5, H. 22.69–22.34m. Kuṣāṇa. L.18/17
7. Complete rattle; hollow globular body with tiny pebbles inside for rattling; traces of colouring; long neck; handle shaped like a half-opened flower. Ø 6.2cm. H. 8.6cm. Colour: brown. No. So III A 550. FS. 2 IV 12.85/Ca 8.05, H. 24.25m. Gupta. L.15
8. Handle of a rattle shaped like a half-opened flower with rounded petals. H. 5.3cm. Colour: brown. No. So III A 595. FS. 2 V 3.5–9.5/Ca 9.5–10.5, H. 24.80–24.30m. Late Gupta. L.14/13.

Miscellaneous Objects

1. Pyriform jar, carinated rim. This jar contains thirty-six identical toe bones of the left front feet of zebus. H. 21.1cm. Brick-red, medium fine fabric. No. So II 3064. FS. 2 IV 11.07/Ca 5.75, H. 15.55m. Early Maurya. L.35
2. Indefinite oval terracotta object of rough structure with a perforation near top end. Loom-weight? Ø 9.4cm. Depth 2.1cm. Dull red. No. So III A 3053. FS. 2 IV 4.0–6.0/Be 18.0–19.5, H. 17.72–17.58m. Late Maurya. L.32
Note: 6 more specimens from Periods III to V registered under So III A 139; 909; 2045; 2348; 2360; 3291.
3. Indefinite terracotta object of conical shape (truncated cone) with vertical perforation from top to bottom. H. 4.9cm. Colour: brown. No. So III A 3504. FS. 2 IV 0.5–4.0/Cc 0.5–3.4, H. 16.55–16.40m. Śuṅga C.P., L.31/30
Note: 5 more specimens from Periods III to VII registered under So III A 189; 190; 316; 1532; 3602.
4. Small spoon(?). Crudely made. L. 4.0cm. Colour: brown. No. So III A 3576. FS. 1.2–2.4/Cc 0.5–2.85, H. 17.55–17.40m. Mitra. L.27
5. Rectangular dish with one corner separated by a rounded partition. Edges all over decorated with notches. 26.0 × 18.5 × 3.2cm. Brown. No. So III A 3709. FS. 2 V 7.2–9.8/Cc 4.1–6.2, H. 18.30–18.15m. Mitra. L.26
6. Hand-modelled handle with moulded face of a monkey, in tilted position on fragment of wheel-thrown pot. H. 10.4cm. Colour: brick-red. No. So I 253. FS. 2 V 12.5/Ca 9.0, H. 18.85m. Mitra. L.26
7. Unidentified terracotta object. 19.3 × 15.9 × 3.5cm. Brown. No. So III A 3535. FS. 2 III 17.15/Cc 9.4, H. 19.15m. Kṣatrapa. L.23

8. Indefinite, decorated terracotta object with vertical perforation.

H. 3.7 cm. Colour: brown. No. So III A 2939.
FS. 2 IV 13.0–19.6/Ca 9.5–10.5, H. 22.50–22.14 m.
Kuṣāṇa. L.19

9. Plug with the head of a snake and a transverse perforation through the conical end. Stopper?

H. 4.7 cm. Colour: brown. No. So III A 2676.
FS. 2 III 14.5–17.5/Cb 19.5–Cc 9.5, H. 22.64–22.34 m.
Kuṣāṇa. L.18

10. Stopper with short conical stem and high knob with traces of incisions on top.

H. 4.66 cm. Colour: grey. No. So III A 1426.
FS. 2 III 7.0–9.5/Cc 0.5–9.5, H. 22.94–22.60 m.
Kuṣāṇa. L.17

11. Complete ladle with plain handle.

L. 21.0 cm. Ø 9.9 cm. Dull red. No. So III A 492.
FS.3 I 3.85/Ca 12.5, H. 23.65 m. Late Kuṣāṇa. L.16

12. Toy Gun with flash hole and touch pan straight on the side of the tube end.

L. 7.3 cm. Colour: red. No. So III A 80.
FS. 2 IV/CB, H. 28.50–28.30 m. Jāt. L.2

13. Toy Gun with flash hole and touch pan slightly higher than in no. 10.

L. 7.6 cm. Colour: red. No. So III A 223.
FS. 2 IV 0.5–9.5/Be 17.8–19.5, H. 26.35–26.00 m.
Jāt. L.6



1



2



3



4



5



6



7



8



9



10



11



12



1



2



3



4



5



6



7



8

Terracotta Bangles. Period I-II (1-4), Period III-V (5-12); Terracotta Amulet and Pendants

13



1



2



3



4



5



6

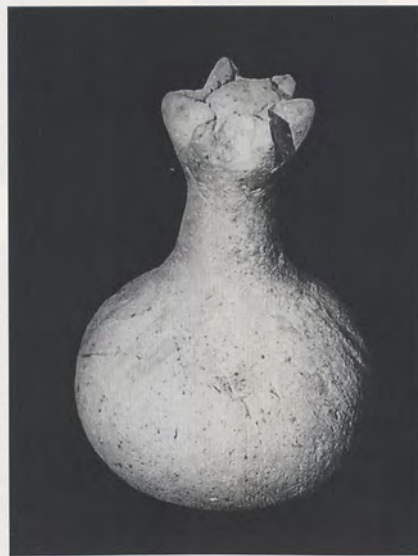

7



8



1



2



3



4



5



6

13



7



8



9



10

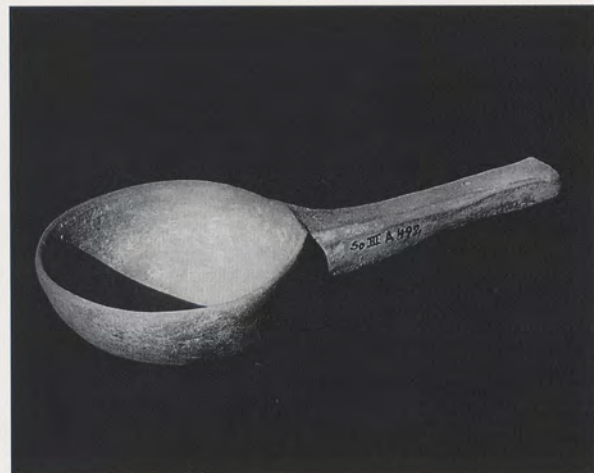

11



12



13

B. STONE OBJECTS

1. Stone Sculptures

The main excavation area at Sonkh yielded not less than 101 fragments of stone sculptures, all but a few belonging to the Kuṣāṇa period. The bulk of them consists of small pieces of cross-bars, coping-stones and pillars of stone-railings. Most of these fragments have been found in the filling of houses of levels 17 to 14. This is an extraordinary fact, indicating that the foundations of newly built houses in the late Kuṣāṇa period were resting on rubble containing sculptural fragments of just a little earlier Kuṣāṇa origin. As most of the finds come from stone-railings the material must have been brought from places of already disused temples in the near neighbourhood, presumably the area of the canal where also the Nāga temple (see Part II) is situated. The iconography of some of the fragments proves that there must have existed more than one temple in the canal region, because they include depictions opposing Nāga worship (e.g. no. 26) as performed in the Apsidal Temple no. 2.

Some of the fragments represent small plaques showing gods like Vāsudeva, Skanda, Durgā Mahiṣāsūramardīnī etc. which might have been used for worship in the homes. Such pieces are not a part of the filling but have most probably been found in situ. Most of the architectural pieces, especially those of cross-bars, are so tiny or so hopelessly destroyed that they are not worth to be published, the more so, as the rich material in Part II covers all the different patterns. But 39 fragments remain, worth to be documented here. Among them, no. 1 and no. 25 deserve special attention, the first one because it was found immediately in the apse of Temple no. 1, the second one because it is, in spite of its unstratified find-spot, the only fragment of stone-sculpture of pre-Kuṣāṇa origin from Sonkh.

Images

1. Plaque showing canopied Mātṛkā squatting in godohika-āsana on a seat with crossing bars on the front side between which the toes of the inserted feet are visible, while the anklets rest on a sort of platform. The goddess is clad in a garment the end of which is draped over her left shoulder, and wears ear-rings and necklace. The middle-part of the hair is placed like a toupee over the side-strands. An ūrṇā is incised between the bulgy eyebrows. The goddess carries a cylindrical vessel in the left hand and a decorated glass in her upraised right hand. She is flanked by four adorers, two each on either side, all in the añjali pose.

This piece is published by N. P. Joshi (1986), p. 115f., line drawing 5 and identified as Vāruṇī or Madirā.

Size: 19.0 × 13.6 × 3.7 cm. Mottled red sandstone.

No. So I 160. FS. 2 IV 14.7/Cb 12.55, H. 23.10 m.

Kuṣāṇa. L.17

Found on the floor lying in front of a platform constructed as a sort of an altar in the Apsidal Temple no. 1. The image was perhaps reinstalled from building stage to building stage.

2. Mutilated base of a Mātṛkā sculpture. Preserved is the part with the crossing rods in front of the seat and the toes of the main figure in between them. To the left side a woman is kneeling with her right knee on a sort of stool while one child is climbing on her upturned left knee. Another child is standing just behind.

Size: 15.3 × 17.0 × 9.3 cm. Mottled red sandstone.

No. So I 130. FS. Filling of late Kuṣāṇa houses. Undoubtedly of Kuṣāṇa origin.

3. Lower part of a plaque showing the scene of Durgā killing the buffalo demon Mahiṣa. The body of the buffalo stretches from left to right resting on the knees of the goddess who is pressing her right hand on the back and grasping with the left the neck of the animal. The front legs of the buffalo are drawn up, the body shows skin-folds indicated by oblique scratches. Durgā is standing on a pedestal, her left leg is covered with cloth, a shawl-end appearing between the legs which are adorned with anklets. The relief is framed by a single line cut along and near the edge, excluding the lower part of pedestal.

Size: 14.2 × 11.5 × 4.0 cm. Mottled red sandstone.

No. So I 128. FS. Filling of late Kuṣāṇa houses. Undoubtedly of Kuṣāṇa origin.

4. Lower part of a damaged Durgā Mahiṣāsūramardīnī plaque. Preserved is the splintered hind-part and body of the buffalo with the right hand of the goddess on its back and the right leg of her with part of the garment covering it. The left leg, now mostly broken off, was set slightly apart. Goddess and animal are standing on a plinth which is irregularly punctured.

Size: 17.9 × 12.7 × 6.6 cm. Mottled red sandstone.

No. So III B 411. FS. 2 IV 0.9/Ca 5.8, H. 22.55 m.

Kuṣāṇa. L.19

5. Fragment of a Durgā Mahiṣāsūramardīnī plaque showing the buffalo with drawn up front legs in front of the goddess preserved only from the upper waist down to the knees. Her body and lower arms are conspicuously slim and slender. The right hand presses the back of the Mahiṣa, the left is placed on his neck. The right hand of the goddess as well as the visible eye of the buffalo are marked by incisions only. The back of the plaque is flat.

9.0 × 10.0 × 3.1 cm. Heavily spotted red sandstone.

No. So III B 314. FS. 2 IV 12.95/Cc 2.6, H. 23.15 m.

Late Kuṣāṇa. L.16

6. Fragmentary plaque depicting four-armed Vāsudeva. The god stands frontal, the right lower hand is raised with palm turned inwards and the back right hand placed on the thick end of an upright *gadā*. The back left hand (formerly holding *cakra*) is broken off, the hand of the lower left arm shows traces of a *śaṅkha*. Vāsudeva's face is stern, the heavily bent eyebrows are incised. On the head is placed a cylindrical crown decorated with crossing lines. The god wears necklace and *upavīta*, the nipples are shown as small rosettes. He is clad in a dhotī, a shawl-end of which appears on the left shoulder together with a *vanamālā* hanging down to the left knee. Girdle and folds of the garment are marked by incised double-lines. The back plate is partly chipped off.

14.2 × 7.4 × 2.4 cm. Heavily spotted red sandstone.

No. So I 145. FS. 2 IV 9.0/Ca 15.8, H. 23.45 m.

Late Kuṣāṇa. L.16

7. Mutilated plaque of four-armed Vāsudeva. Right arms, face, crown and most of the left arms are broken off. Preserved is the body with pearl-string (*ekāvalī*), elegantly knotted girdle, horizontally incised folds of garment, and the upper part of the lower left arm with a stripe of shawl. In better condition is the left upper arm holding a large *cakra* which is shaped like a wheel with prominent hub.

Originally the front arms were lowered, carrying a flower (for *padma*) in the right, and *śaṅkha* in the left hand. The figure of the god stands in high relief before a plain, thick back-plate.

Size: 18.0 × 9.8 × 6.2 cm. Mottled red sandstone.

No. So I 126. FS. Found within the east rampart of L.5. Although the style betrays Gupta features, the back arms are positioned as in Vāsudeva figures of the Kuṣāṇa period. The date of this sculpture ranges between Late Kuṣāṇa and Early Gupta.

8. Fragmentary plaque showing standing two-armed god Skanda from the face down to the knees. The partly chipped off right arm is raised, its hand turned slightly inwards (*vyāvṛtta mudrā*). The left arm is bent with the elbow pointing outwards keeping the upright shaft of a spear with its hand. Skanda is wearing ear-rings, necklace and *upavīta*. He is clad in a dhotī, with the fabric gathered between his legs, and a bulky scarf hanging down from the right hip to the left thigh, presumably ending in a loop below the left hip. On the left the plaque is bordered by a single vertical line incised near the edge.

Size: 11.0 × 8.5 × 3.6 cm. Mottled red sandstone.

No. So I 134. FS. 2 IV 9.0/Ca 19.4, H. 24.00 m.

Late Kuṣāṇa. L.16/15

9. Fragmentary and mutilated plaque showing the remains of Skanda riding on a peacock facing front. Head broken off, neck and chest damaged. Right arm raised with palm of hand turned inwards (*vyāvṛtta*). The left hand holds the shaft of a weapon (spear or club). In the lower part of the fragment the outspread wings of a peacock are visible, in the midst the traces of the damaged frontal body of the bird.

Size: 8.2 × 8.8 × 2.1 cm. Mottled red sandstone.

No. So I 109. FS. In the filling of Gupta levels 15/14.

10. Upper part of a plaque with the canopied head of a woman. Face split off between the eyes from forehead to the tip of nose. Thick, strongly bent brows; large, open eyes. Hairs curled horizontally, intersected, however, by a vertically combed flat "cushion". The woman wears large grooved ear-rings and necklace. Upraised right hand chipped off. Three petals of lotus at the left shoulder permit to identify the figure as goddess Lakṣmī.

Size: 10.8 × 16.5 × 5.0 cm. Mottled red sandstone.

No. So I 117. FS. 3 I 0.6/Ca 8.45, H. 23.60 m.

Late Kuṣāṇa. L.16

11. Fragment of a plaque showing seated Kubera. Head, hands, left leg and feet broken off; chest split off. The objects held in the hands remain unclear. Kubera wears necklace and *udarabandha* (?) and is clad in a short plaited garment held by a girdle knotted in front.

Size: 11.3 × 11.5 × 4.1 cm. Spotted red sandstone.

No. So I 135. FS. Filling. Out of context. Undoubtedly Kuṣāṇa.

12. Part of a Dampati plaque showing head and chest of a man and the right arm of an accompanying female. Head of the man worn, face with large, open eyes; eyebrows strongly curved. He wears ear-rings and broad, triangularly arranged necklace. The split off right hand is raised. To the right the arm of a second figure extended towards the back of the man is visible. The right ear-ring of this (female) figure meets the left shoulder of the man who was presumably stretching his left arm behind his companion. The back of the plaque is flat.

Size: 6.4 × 7.2 × 3.2 cm. Mottled red sandstone.

No. So I 107. FS. Filling in Gupta level 15.

13. Mutilated head of a Garuḍa. Bulging eyeballs in deep eye-sockets. Long, pointed nose.

H. 10.3 cm. Heavily spotted red sandstone.

No. So III B 315. FS. 2 IV 9.28/Ca 19.25, H. 24.05 m.

Gupta. L.15

14. Worn face of a larger human (presumably female) figure. Hair styled like a crown. Traces of flower-rosettes in front(?). Nose and upper lip chipped off. Eyebrows strongly bent. Large *ūrṇā* carved above root of the nose.

H. 19.5 cm. Mottled red sandstone.

No So I 153. FS. Filling in L.16/15.

15. Head of a male figure. Face heavily worn. Hair combed backwards. Upon it a wreath of rhombic pattern laid around the head and terminating in a knot at its back.

H. 10.4 cm. Spotted red sandstone.

No. So I 151. FS. Filling in L.14

16. Small head of a male figure. Face heavily worn. Large, round diadem on scarf-covered hair. From the back of the head a plaited shawl hangs down to the shoulders.

H. 5.3 cm. Heavily mottled red sandstone.

No. So I 111. FS. Filling in rampart.

17. Lower part of a plaque showing a male figure from waist to feet. In his now mutilated left hand he seems to hold a flask. He wears a double-stringed girdle and a garment gathered in folds between the legs. A bulky scarf falls from the left hip to the right knee. The figure stands on a now broken off plinth. The plaque is bordered by a single line carved along the edge.

H. 9.6 cm. Yellow layer of spotted red sandstone.

No. So III B 292. FS. 3 I 1.4/Ca 8.75, H. 22.70 m.

Kuṣāṇa. L.18

18. Lower part of a relief preserving the legs of a female with dented anklets. Between the legs the end of a shaft standing slightly oblique. To the right incised folds of garment. Traces of a scarf are visible hanging down from the left thigh to the right leg. The figure stands on a plinth terminating in a tenon. The back is flat.

H. 14.6 cm. Mottled red sandstone.

No. So I 165. FS. Filling of late Kuṣāṇa house.

19. Fragment of a stone halo with remains of a lotus rosette and a flying figure holding a flower stalk.

7.2 × 6.3 × 3.2 cm. Mottled red sandstone. No. So I 168.

FS. 2 V 0.1/Ca 12.5, H. 23.68 m. Gupta. L.15

20. Fragment of a relief showing a right hand on the handle of a weapon, probably a sword.

Size: 14.5 × 18.5 × 6.3 cm. Red sandstone.

No. So I 152. FS. Filling in L.14

21. Fragment of a left hand holding the handle of an indefinite object terminating in a sort of jewel which is combined with a jewelled chain.

Size: 4.5 × 4.5 × 3.5 cm. Grey sandstone.

No. So III B 199. FS. Surface find.

22. Four fragments of a flat relief depicting a lion attacking a bull. The scene is bordered by decorated framework.

Size: 32.0 × 14.5 × 2.5 cm. Violet-red sandstone.

No. So I 237. FS. Filling in rampart.

23. Fragment of a relief. Lower edge with two half lotus rosettes between which are placed the feet of two persons turned towards each other. This scene is bordered below by a frame decorated with railing pattern. Perforation work. At the back oblique strokes.

Size: 5.0 × 20.2 × 2.6 cm. Violet-red sandstone.

No. So I 23. FS. Filling in rampart.

24. Fragment of carved fossilized wood with the remains of a standing figure showing right arm bent and wearing a tunic and trousers.

H. 7.46 cm. Fossilized wood. No. So I 332.

FS. Surface find.

Architectural Pieces

25. Fragment of an indefinite architectural piece with a nearly horizontal beam and the remains of a relief. The capstone ends on the left and shows traces of a vertical tenon for joining onto the next part. The relief shows the upper part of a roughly carved and weather-worn goddess Lakṣmī with one-sided bulge of hair, oversized ear-rings, necklace, and a lotus-crown on top. The right arm is bent upwards, the raised hand holding a half-blown lotus. Size: 14.2 × 10.4 × 7.0 cm. Yellowish sandstone, most probably light vein of Kerauli stone.

No. So I 71. FS. Reused in wall of Jāṭ level 6.

On account of its style and stone the piece originates from pre-Kuṣāṇa levels and is, therefore, the oldest stone sculptural find from Sonkh.

26. Fragment of a tympanum carved on both sides. The relief with an almost identical reverse side depicts the mythical bird Garuḍa above a curved lotus border. With wings spread out he stands upright and carries a three-headed serpent in his beak. The body of the snake coils itself around the bird's neck and slides down behind the left wing. This serpentine line, along with leaf and blossom ornaments, produces a decorative pattern corresponding to the twig-like and raised tail of the Garuḍa on the other side of the legs. Below the lotus border remains of winged animals are preserved.

On comparing this object with similar pieces one may conclude that originally another curved border below the animals existed as a dividing line for a third scene.

Size: 50.5 × 31.8 × 5.0 cm. Mottled red sandstone.

No. So I 110. FS. Within the debris used as filling above L.16.

27. Head of a lion. Finely carved face, mane and ears. Circle of iris and pupil inserted in the eyeball. Brows marked by oblique notches. Wavy hairs cut around the muzzle. Left turned *svastikas* incised on the cheeks.

Long grooves in the flat area behind the mane prove that the head is not the severed part of a complete lion but was serving as an architectural decoration.

9.0 × 13.6 × 6.6 cm. Spotted red sandstone.

No. So I 150. FS. 2 IV 12.6/Ca 5.8, H. 23.50 m.

Late Kuṣāṇa. L.16

28. Disc of a small *chattra* with central perforation. On top plain and rounded. Below, a deepened circle is laid around a prominent hub, both decorated with lotus leaves.

Ø 9.2 cm. H. 2.0 cm. Spotted red sandstone.

No. So I 158. FS. 2 V 12.95/Cb 3.25, H. 22.57 m.

Kuṣāṇa. L.18

29. Small capital decorated with upturned leaves on the four sides. On top a hub and one hole each is carved at the four corners. Size: 7.8 × 6.8 × 6.0 cm. Yellowish sandstone, most probably vein of Kerauli stone.

No. So III B 275. FS. 2 IV 12.55/Ca 3.8, H. 23.60 m.

Late Kuṣāṇa. L.16

30. Fragment of architectural piece shaped as kind of cornice with carved caitya-window and squares showing rosette and crossflower separated by deep-cut grooves.

Size: 20.5 × 21.5 × 15.0 cm. Mottled red sandstone.

No. So I 243. FS. Filling in late Kuṣāṇa house.

31. Fragment of a small railing pillar carved on both sides with half a lotus rosette immediately at the base and a full one above it. In the circle-spandrels small blossoms. Space between rosettes triply fluted. Plain border and plain end.

Size: 15.0 × 8.0 × 7.0 cm. Mottled red sandstone.

No. So I 59. Filling in rampart.

32. Cross-bar with lotus rosette and four spandrel blossoms in high relief on both sides of the lenticularly sectioned stone. The shape of the petals and the decor of the centres of the two rosettes differ clearly.

Size: 37.0 × 18.5 × 5.3 cm. Mottled red sandstone.

No. So I 236. FS. Filling in Late Kuṣāṇa house.

33. Splintered fragment of an architectural piece, presumably a railing pillar because of its fluted surface. A lotus rosette with spandrel-blossoms covers the width of the stone. The lotus shows open petals. The edges are plain, the back broken off.

Size: 27.0 × 18.3 × 6.5 cm. Mottled red sandstone.

No. So I 184. FS. Filling in late Kuṣāṇa house.

34. Fragment of a lotus rosette from an architectural piece. Petals with the points of more petals in between. Rare type of border decorated with adversifoliate creeper. Back smoothed as if used for grinding.

Size: 10.5 × 8.7 × 2.7 cm. Mottled red sandstone.

No. So I 311. FS. Surface find.

35. Fragment of a cross-bar with lotus petals. The petals show double contours and are carved in high relief.

Size: 12.3 × 11.8 × 4.0 cm. Mottled red sandstone.

No. So I 195. FS. Filling in house of L.21.

36. Fragment of a cross-bar, both sides carved with a lotus rosette and spandrel-blossom of varying kind.

Size: 15.5 × 11.5 × 5.5 cm. Mottled red sandstone.

No. So I 177. FS. Filling in house of L.20.

37. Small fragment of a cross-bar with part of a lotus rosette carved on both sides. Shape of petals considerably different.

Size: 10.0 × 10.0 × 5.0 cm. Mottled red sandstone.

No. So I 140. FS. Filling in rampart.

38. Fragment of a crossbar with remains of differently carved lotus rosettes on both sides.

Size: 11.8 × 11.2 × 4.9 cm. Mottled red sandstone.

No. So III B 433. FS. Filling in house of L.18/17.

39. Fragment of a cross-bar with remains of differently shaped lotus rosettes on both sides.

Size: 12.4 × 10.1 × 4.8 cm. Mottled red sandstone.

No. So III B 350. FS. Filling in house of L.19.

Grey Stone Plaques

A special group of stone images are the small plaques made of grey stone depicting brahmanical deities found in post-Gupta to medieval levels. They are made of shale or slate splintering easily. This accounts for so many tiny fragments among the altogether 80 pieces of such plaques recovered during the excavation. The few fully preserved icons and the larger fragments show plaques which measured between 6.0 and 14.0cm in height when complete. They were quite obviously images for domestic worship and seem to depict exclusively brahmanical deities. The identification is not always easy because the workmanship is, as a rule, rather crude, of rough sketching and stylized delineation. There is often no detailed depiction of attributes so important for recognition.

The deities represented in the Sonkh plaques are Sūrya, Viṣṇu, Durgā as Mahiṣāsura-mardīnī, and Gaṇeśa. A number of unidentified fragments shows an even richer iconographical spectrum. The find-spots ranging between level 15 and 8 do not help to establish a stylistic development because these so easily transportable plaques have obviously been used by generations, one after the other. Nearest to Gupta style stands no. 1 with its curled hair-do, while most of the others seem to be of later origin. Iconographical differences offer the Viṣṇu plaques nos. 4 to 7 in comparison with no. 8. While the first shows the attributes *cakra* and *gadā* standing on the ground with the god's hands upon it, no. 8 depicts him carrying *śaṅkha* in his left lower hand. But all that one can safely say is that these plaques have, according to their find-places in Sonkh, to be dated between 7th and 13th century AD. They are not modern products as sometimes stated.

1. Upper half of a plaque depicting god Sūrya. Presumably seated in a chariot, having raised his two arms holding with the hands one lotus-stalk each showing a triangularly shaped leaf turned sideways and a full blossom hanging down between stalks and head. This head is framed by elegantly curled hair topped by a conical crown. Face, chest and arms are partly chipped off. An elevated plain rim borders the plaque. Under the arms and along the waist the stone is perforated. The back is plain and smooth. 9.5 × 9.5 × 1.6 cm. Colour: grey. No. So I 113. FS. 2 III 19.5/Ca 17.3, H. 25.50m. Medieval. L.11. On account of its style an origin nearer to Gupta is probable.

2. Nearly complete plaque showing Sūrya in a medallion seated on a chariot. The plaque is bordered by an elevated decorated frame shaped like a double-H. Above and below the horizontal beams seven cylindrical projections are carved having incised eyes and hair. In connection with Sūrya one may think of the seven horses and seven sisters, but this pattern is not restricted to Sūrya plaques alone. The medallion is surrounded by a vaulted surface decorated with triple lines. Sūrya sits in godhika-āsana, the arms raised, holding one lotus each in his hands. All details of face, head-dress, ornaments and garment are crudely incised. The hair seems to fall to the shoulders. Characteristic of this type of plaques are the large eyes, nose and mouth. The back is plain. 13.9 × 9.3 × 1.3 cm. Colour: violet-grey. No. So I 85. FS. 2 V 1.1/Ca 0.3, H. 24.73m. Medieval. L.12

3. Fragment of a Sūrya plaque. Preserved is the headless body of the god, clad in a plaited short garment and seated with drawn up legs in a chariot provided with a round balustrade of which three rods are visible. Below to the left a horse with elaborate head-dress is turned sideways, of a second horse to the right only traces of the head and its head-dress is to be made out. The plaque was framed by a plain, slightly rounded border.

8.1 × 8.6 × 1.4 cm. Colour: grey-red. No. So III B 245.

FS. 2 IV 8.75/Cb 4.9, H. 24.50m. Early Medieval. L.13

Note: 5 more fragments of Sūrya plaques registered under So III B 172; 192; 243; 376; 456.

4. Fragmentary plaque depicting standing Viṣṇu. Head-part missing. The god is four-armed, the details of ornaments, *upavīta* and garment are thinly incised. The upper arms are raised, holding the *vanamālā* which is hanging down to the knees. Behind the left hand part of a shawl is visible. The front arms are lowered to the attributes *gadā* and *cakra*, standing on the ground. To the left, a stylized figure is placed before the club, to the right a same arrangement was intended but remained unfinished for want of space. The reverse is plain and smooth.

10.5 × 7.8 × 2.0 cm. Colour: grey. No. So I 108.

FS. 2 V 6.8/Cb 0.6, H. 24.70m. Medieval. L.11

5. Fragment of a plaque with the remains of a standing Viṣṇu preserved from waist to knees. He is clad in a short garment decorated with criss-cross lines forming rhomboid pattern. The girdle is marked by three parallel horizontal lines from which two oblique stripes extend to the lower hem. On the right hip traces of an incised *upavīta*. From the lowered left arm falls the *vanamālā* to the knee. The left hand rests on the remaining upper part of two squared objects, representing most probably *cakra* and *cakrapuruṣa* (cp. no. 4). To the right part of the elevated border decorated with notches.

7.3 × 7.3 × 1.7 cm. Colour: Violet-grey. No. So III B 321.

FS. 2 V 9.73/Cb 19.5, H. 23.10m. Ditch. L.13

6. Lower part of a plaque with the legs and two attributes of Viṣṇu. The god is standing frontal, clad in a long garment the plaits of which reach down to the ankles. To the left stands a massive club (*gadā*), to the right two parts of socle on which a dented *cakra* is placed. The elevated border seems to have been plain. Reverse side smooth.

6.3 × 4.9 × 1.4 cm. Light grey. No. So III B 289.

FS. 2 IV 14.55/Cc 2.4, H. 23.56m. Post-Gupta. L.13

7. Damaged fragments of a Viṣṇu plaque consisting of three combined pieces. Preserved are the legs of the god standing frontal, part of the *vanamālā* hanging to the knees, one left arm placed on an attribute. The legs are covered with a garment the gathered folds of which appear in between. To the sides of the legs the plaque was perforated. The presumably lower left arm is bent downwards, its hand resting on the personified attribute *gadā*. The *gadā-devī* is shaped like a bust placed on a decorated club. She wears a necklace and a piled up coiffure with horizontally arranged strands. The space between this hair-tower and the border is vaulted. Normally one should expect the *cakra* beside this left leg, but hair-dress and shape of the breast prove the figure to be a female. The plaque ends below in a sort of plinth lineated with incised lines and is bordered on the right by an elevated dented frame.

11.3 × 5.1 × 1.4 cm. Colour: grey. No. So III B 246.

FS. 2 IV 9.3/Cb 2.85, H. 24.60m. Post-Gupta. L.13

8. Part of a Viṣṇu plaque consisting of three fragments showing the god standing frontal without head and right arms. Horizontal and oblique incised lines indicate girdle, garment, bracelet and *vanamālā*. The upper left arm is raised, the lower is bent downwards holding in its hand a big *śaṅkha* in oblique position. To the right remains of an elevated dented frame are visible.

9.0 × 6.1 × 1.4 cm. Colour: grey. No. So III B 99.

FS. 2 IV 6.1/Ca 15.7, H. 25.55m. Late Medieval. L.8/7

Note: 4 more fragments of Viṣṇu plaques registered under So III B 98; 110; 231; 317.

9. Fragmentary plaque showing Viṣṇu standing on Kūrma. Crude workmanship does not permit to explain all the details. The god is standing frontal on an animal which is undoubtedly a tortoise. The details like flowery crown, facial features, ornaments, *upavīta* and garment are marked by incisions. On the forehead three vertical Vaiṣṇava strokes! The lower right hand seems to hold a lotus-stalk. The left upper arm is raised, the lower one bent downwards, holding a defaced object in its hand. Behind the tortoise and the legs of Viṣṇu the background is incised with lines and half circles, probably indicating water. On top and to the right the plaque shows an elevated border with criss-cross decoration.

11.1 × 8.6 × 1.3 cm. Colour: Violet-grey. No. So I 119.
FS. 2 IV 3.9/Cb 2.05, H. 24.85 m. Early Medieval. L.12

10. Characteristic face of a grey stone plaque. Details of head-dress and face marked by incised lines. Eyes undercut, nose triangular and oversized, small nostrils, sharply lined broad mouth. Round mark on forehead (*ūrṇā?*).

H. 3.7 cm. Colour: grey. No. So I 79.
FS. 2 IV 17.9/Cb 7.02, H. 25.90 m. Late Medieval. L.8/7
Note: One more head of same type registered under So III B 214.

11. Small plaque showing Durgā with a lion. The iconography is similar to Mahiṣāsuramardīnī depictions, but here the buffalo is absent. The crudely carved goddess is four-armed and, as the position of the legs indicates, seated. She is perhaps meant to be sitting on her lion like a *Siṃhavāhinī*. Her face displays large bulging eyes, long nose and small mouth. The head carries a low crown. In the raised right back hand Durgā holds a sword with the blade horizontally behind the crown, the front right arm is lowered, holding the shaft of a *triśūla* with the hand. The object in the raised left back hand has to be a shield, the lower right arm is bent down, having a flower (?) in the palm of the hand.

8.1 × 4.6 × 1.4 cm. Colour: grey. No. So I 164.
FS. 2 III 17.1/Cb 14.5, H. 23.83 m. Ditch from a level later than 15.

Note: One more indefinite fragment of a female deity registered as So III B 322.

12. Complete plaque of a Gaṇeśa. Large, nearly cylindrical head with right ear, incised eyes, third eye and wrinkles towards the left turned trunk. The god is seated in *godohika-āsana*, the body shaped like a vessel marked with two horizontal lines. The feet stand on a base. The plaque has no elevated border.

6.1 × 3.2 cm. Colour: grey. No. So III B 244.
FS. Filling in 2 V/Cb.

13. Crudely cut plaque with the figure of Gaṇeśa. Head cylindrical as in no. 12, trunk turned left. The figure is seated in *godohika-āsana*, its body is shaped like a plain vessel.

6.2 × 3.7 cm. Colour: grey. No. So III B 124.
FS. Filling in 2 V/Ca.
Note: Two more fragments of Gaṇeśa plaques registered under So III B 78; 120.

14. Fragment of a plaque with the remains of a horse presumably standing on its hind-legs and turned towards the frame of the relief.

7.8 × 6.2 × 1.6 cm. Colour: grey. No. So III B 293.
FS. 2 IV 15.0/Cb 17.5, H. 23.85 m. L.14

15. Fragment of a plaque with unidentified scene.
7.9 × 5.9 × 2.0 cm. Colour: grey. No. So III B 285.
FS. 2 V 8.3/Cb 2.65, H. 23.95 m. L.14

16. Fragment of a mutilated plaque with unidentified scene. Recognizable is a horse's head between conical rods.
8.0 × 8.0 × 1.4 cm. Colour: grey. No. So III B 217.
FS. 2 V 0.5–9.5/Ca 9.5–10.5, H. 25.25–24.90 m.
Medieval. L.11

17. Fragment of a plaque showing remains of a worn rectangular block with a lower rounded figure having incised eyes. Round border decorated with band of oblique strokes.

4.2 × 3.0 × 1.1 cm. Colour: grey. No. So III B 165.
FS. 2 V 2.0/Cb 9.55, H. 25.45 m. Medieval. L.10

18. Fragment of a crudely modelled plaque with unidentified figure. Skanda?

10.3 × 5.3 × 2.1 cm. Colour: grey. No. So III B 186.
FS. 2 IV 1.45/Cb 5.0, H. 24.90 m. Early Medieval. L.12

19. Base part of a plaque with two step-like rectangular objects standing one above the other, decorated with rhomboid incisions. To the left and right remains of a zigzag ornamented frame. The base is embellished with a wavy line cut in between parallel bands.

Size: 8.1 × 6.5 cm. Colour: greyred.
No. So III B 626. FS. Ditch in 2 III/Cb.

Miscellaneous Stone Reliefs

1. Part of a *sattī-sattā* stone showing an angularly carved human figure moving to left, the right arm holding the hand of a second person following him. The figure stands in relief on the rough background.

28.0 × 13.5 cm. Colour: dull red. No. So III B 135.
FS. 2 IV 19.1/Cb 6.1, H. 25.60 m. Pre-Jāt. L.7

2. *Sattī-sattā* stone with the depiction of two figures with raised arms moving to left. Background of figures rough. To the sides of the figures illegible remains of script, perhaps names.

Size: 44.0 × 31.0 cm. Colour: Mottled red sandstone.
No. So I 65. FS. Reused as covering plate in L.4
Note: 3 more small fragments of *sattī-sattā* stones from Jāt levels registered under So III B 2; 34; 104.

3. Large stone beam with carving of a 30.0 by 25.5 cm measuring relief depicting an archer in the act of shooting. The man has turned to his left carrying a quiver over his right shoulder and stretching the bow with his arms ready to speed the arrow. The bow shows irregular bulges, perhaps traces of flowers?

56.5 × 27.5 × 18.5 cm. Colour: Mottled red sandstone.
No. So I 105. FS. 2 V 14.6/Ca 9.6, H. 26.40 m. Jāt. L.5

4. Fragment of a stone relief with the remains of a monkey-warrior holding a shield in his raised hand.

Size: 16.1 × 9.2 × 4.5 cm. Colour: grey-black.
No. So I 53. FS. 2 V 6.0/Cb 2.9, H. 27.15 m. Jāt. L.4



1



2



3

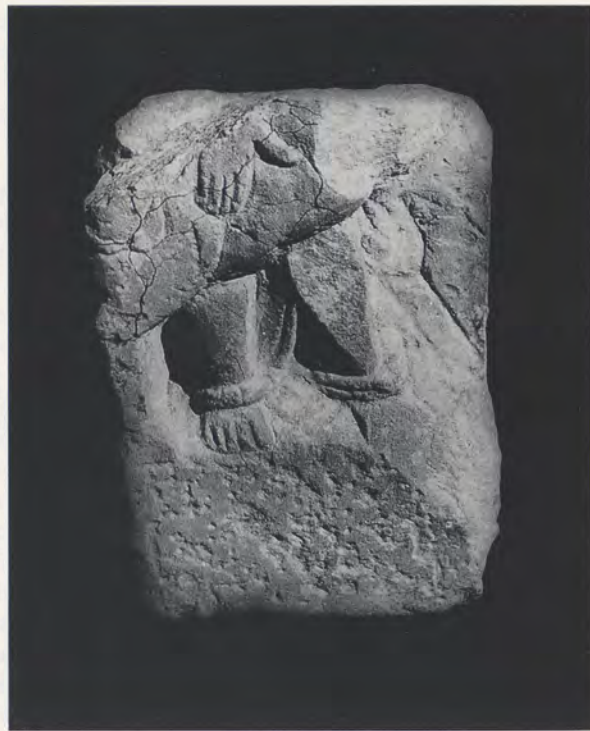

4



5



6



7a

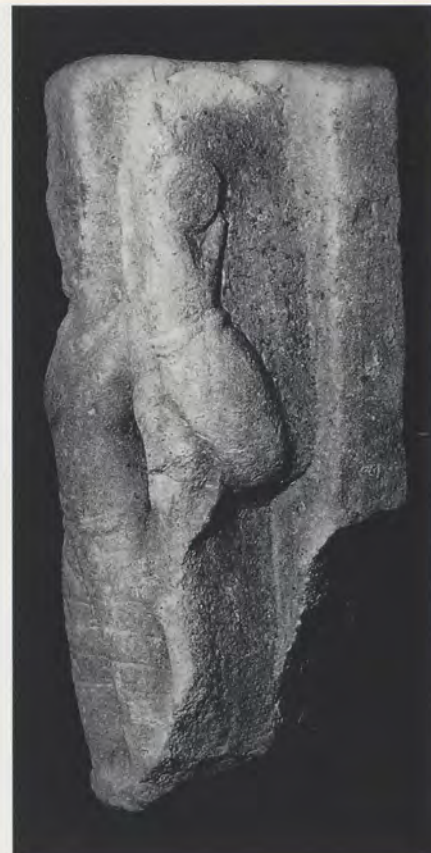

7b



8



9



10



11



12



14



15



13



16a



16b



17



18



19



20



21



24



22



23



26a



26b



25



27



28a



28b

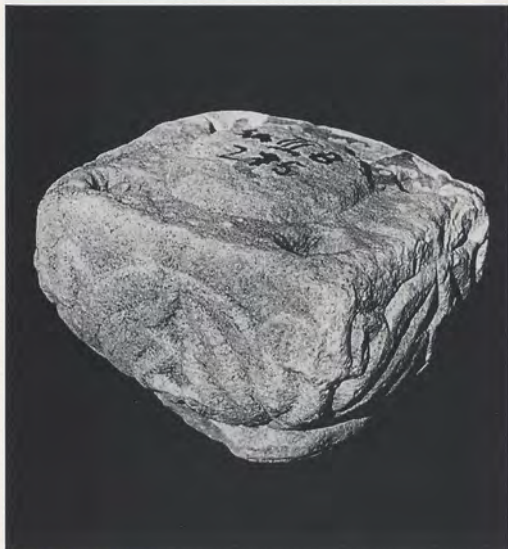

29



30



31



32a



32b



33



34



35



36a, b



37a, b



38a, b



39a



39b

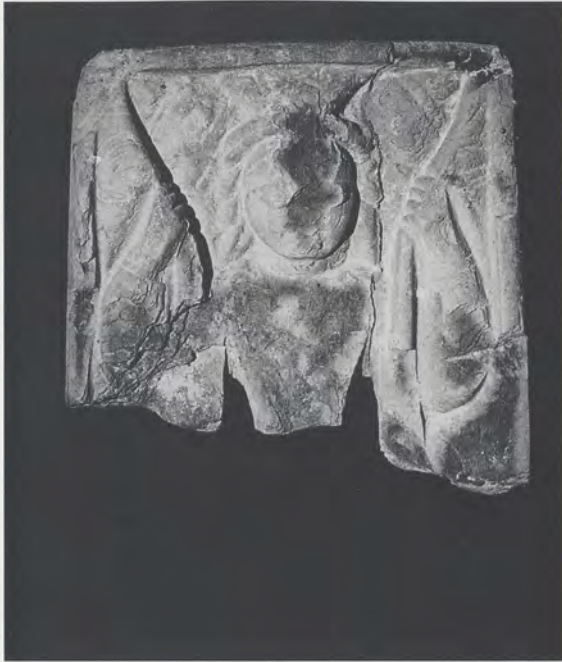

1



2



3



4



5

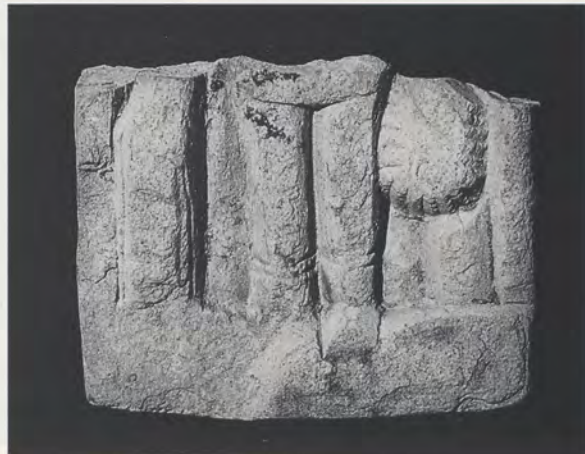

6



7



8



9



10



11



12

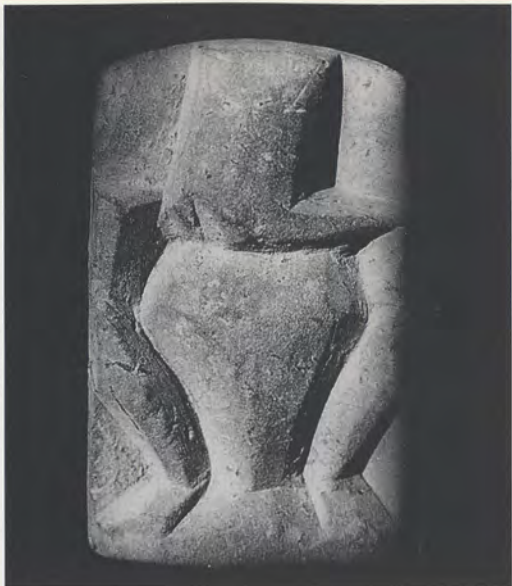

13



14



15



16



17



18



19

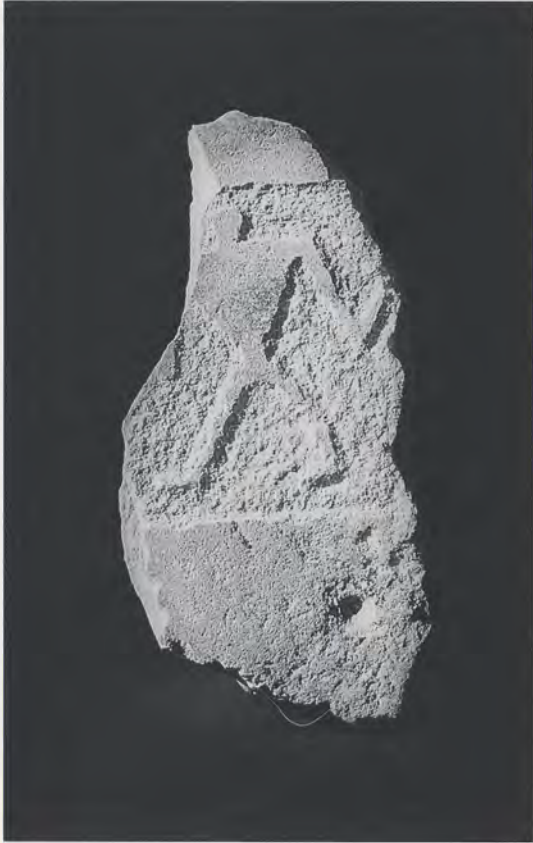

1

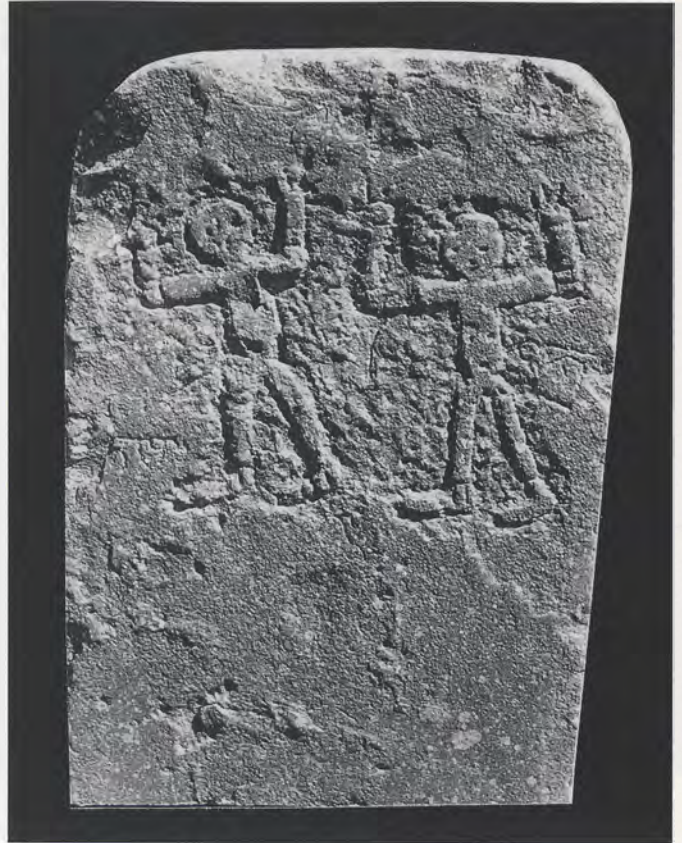

2



3



4

2. Miscellaneous Stone Objects

Trays and Plaques

24 fragments of rectangular or round stone trays and plaques were recovered in the levels of the Kuṣāṇa period and later. All are provided with incised or carved decorations. Most of them seem to be from toilet-trays with dish-like centre, others may have been flat plates. The fourteen larger and significant pieces are illustrated and described here.

1. Fragment of a flat rectangular plaque with circular centre marked by a single circumference line and decorated in the preserved corner with the contours of a finely incised blossom.

Size: 8.05 × 6.65 × 1.27 cm. Mottled red sandstone.
No. So III B 364. FS 2 IV 11.0/Cb 1.5, H. 22.83 m.
Kuṣāṇa. L.17

2. Fragment of a rectangular tray with central dish and carved ornaments. In the corner a plain circle with elevated edge touching the border of leaves surrounding the damaged centre. Above it appears the head of a fish running across a spiny object, perhaps another aquatic animal.

5.4 × 4.5 × 0.5 cm. Light grey slate. No. So III B 262.
FS. 2 V 3.0/Cb 3.8, H. 23.15 m. Kuṣāṇa. L.17

3. Fragment of a round plaque with presumably plain centre bordered with a circle of pointed petals. Between this circle and the outer edge a band decorated with two thick lotus-stalks and two horses is carved. The reverse is plain.

Size: 9.5 × 8.7 × 1.8 cm. Grey-black slate.
No. So I 120. FS. Filling in 2 V/Ca.

4. Fragment of a rectangular tray with plain centre bordered with carved pointed lotus-petals framed by incised double-lined circles. Towards the edge other floral ornaments are visible. The reverse is flat and undecorated.

9.5 × 8.5 × 1.8 cm. Violet-grey slate. No. So I 116.
FS.3 I 3.15/Ca 13.85, H. 23.40 m. Late Kuṣāṇa. L.16

5. Fragment of a square tray. Plain centre encircled by an incised border of pointed lotus-petals. The edge of the tray is marked by a single framing line.

6.6 × 4.1 × 1.3 cm. Grey slate. No. So III B 436.
FS. 2 III 9.1/Cc 3.1, H. 22.20 m. Ditch in L.18

6. Damaged square tray with plain centre framed by a circle of small lotus petals. The corners are filled with larger petals arranged upon each other.

9.0 × 8.5 × 1.4 cm. Grey slate. No. So III B 241.
FS.2 IV 18.9/Ca 13.85, H. 23.85 m. Late Kuṣāṇa. L.16

7. Round stone tray with plain centre framed by incised concentric circles and a border of pointed lotus-petals.

Ø 12.0 cm. Depth 0.6 cm. Grey slate. No. So III B 218.
FS. Filling in 2 IV/Ca. Early Medieval.

8. Mutilated rectangular plaque with slightly elevated circular centre encircled by a concave line. The corners are decorated with hearts on the same level as the central circle. The remaining space is incised with rhomboid patterns.

11.9 × 11.7 × 1.2 cm. Grey slate. No. So III B 277.
FS. 2 IV 12.85/Ca 8.25, H. 23.60 m. Gupta? L.15

9. Fragment of a rectangular tray with plain deepened centre, worn scratched decoration and incised heart ornament in the preserved corner.

7.5 × 6.5 × 1.8 cm. Grey mudstone(?). No. So III B 242.
FS. 2 IV 4.0/Cb 2.2, H. 24.10 m. Early Medieval. L.13

10. Fragment of a rectangular tray with a heart carved in the corner and with various incised patterns around, edged by a zig-zag-border.

Size: 6.3 × 6.2 × 1.1 cm. Violet-grey slate.
No. So III B 320. FS. Filling in 2 IV/Cb.

11. Mutilated square tray with deepened circular centre surrounded with a single line from which crude incisions radiate towards the edge of the plaque.

8.2 × 8.2 × 1.4 cm. Grey slate. No. So III B 240.
FS. Filling in 2 V/Cb. Medieval. L.12

12. Small fragment of a rectangular plaque with circular, rhomboid and oblique incisions.

5.0 × 4.6 × 1.3 cm. Grey slate. No. So III B 155.
FS. Filling in 2 V/Ca. Medieval.

13. Fragment of a rectangular tray with plain centre encircled by concentric lines. Between circles and edge rhomboid incisions.

Size: 6.2 × 6.3 × 1.3 cm. Grey slate.
No. So III B 523. FS. Surface find.

14. Mutilated fragment of a large tray with traces of a plain deepened centre encircled by a border of pointed lotus-petals. In the outer circular band large blossoms have been incised.

Ø 24.0 cm. Depth 1.3 cm. Grey sandstone.
No. So III B 237. FS. Filling in 2 V/Cb.

Caskets and Lids

The finds of fragments of stone caskets and their lids are confined to the Periods III to V (i.e. Mitra to Kuṣāṇa). Altogether 64 such fragments, mostly tiny and insignificant, have been recovered from levels 26 to 16 with a clear concentration in the Kṣatrapa levels 24 to 23. The material is soapstone (steatite) of different colour or slate. As far as measurable, the diameter of these through-out small vessels varies between 4.0 and 9.0 cm. With few exceptions all specimens are more or less decorated. 18 pieces have been selected as sufficiently significant and will be depicted here. Two of these fragments do not stand for caskets but represent jarlet and normal bowl.

1. Bowl of a small casket with flat base and sharply edged flange rim for the (missing) lid. The bowl is decorated with a triple horizontal line incised around the body. Fine workmanship. Ø 5.6 cm. H. 2.3 cm. Steatite, white with red spots. No. So I 252. FS.3 I 1.7/Cb 3.4, H. 18.80 m. Mitra. L.26
2. Fragment of a casket-bowl with flange rim for lid. A horizontal groove decorates the body of the bowl. L. 5.2 cm. Steatite, green-grey. No. So III B 521. FS. 3 I 2.0/Ca 18.3, H. 18.70 m. Mitra. L.26
3. Lid of a soapstone casket with conical top and curved lower half, having a sharply edged flange for fitting it onto the bowl. Ø 5.4 cm. H. 1.4 cm. Colour: brown. No. So III B 598. FS. 2 V 18.0/Cb 4.0, H. 19.30 m. Late Mitra. L.25/24
4. Fragment of a casket-bowl of conical shape with flat base and deeply grooved flange rim as rest for the lid. Body decorated with a frieze of flowers and haṃsas in succession. H. 3.2 cm. B.6.6 cm. Steatite, grey-black. No. So I 337. FS.2 IV 13.04/Cc 2.55, H. 19.12 m. Early Kṣatrapa. L.24/23
5. Fragmentary casket-bowl. Curved wall and bottom decorated with grooved horizontal lines and a band of ridges along the circumference. Socket rim with narrow ledge. H. 3.2 cm. B.4.8 cm. Steatite, white with red spots. No. So III B 524. FS. 2 V 18.1/Ca 9.0, H. 20.10 m. Kṣatrapa. L.23
6. Fragment of a small steatite casket. Hemispherical body plain. Rim worked out as rest for the lid (flange rim). 3.2 × 4.5 cm. Colour: dark grey. No. So III B 672. FS. 2 V 8.0/Cb 16.0, H. 19.70 m. Kṣatrapa. L.23
7. Fragmentary steatite bowl with flat foot. One grooved horizontal line running around the lower part of the vessel. 2.9 × 3.3 cm. Colour: brown. No. So III B 716. FS. 2 IV 16.75/Cc 3.4, H. 19.35 m. Kṣatrapa. L.23
8. Fragment of a shallow steatite bowl decorated on the inside with concentric lines and ridges, with a prominent ridge below rim outside. Ø 7.2 cm. H. 2.2 cm. Colour: grey-brown. No. So III B 602. FS. 2 V 11.8/Cb 13.0, H. 19.40 m. Kṣatrapa. L.23
9. Mutilated serpentine jarlet showing bulging sides, flat base, grooved shoulder and beaded rim. A large lotus rosette is incised on the body. Ø 4.9 cm. Colour: green-black. No. So III B 757. FS. 2 V 19.5–3 I 0.8/Cc 3.6–4.7, H. 19.30–19.05 m. Early Kṣatrapa. L.24/23
10. Flat lid of a steatite casket. On top two decorative circular lines running along the edge, in the centre one larger and two

smaller circles pretending a knob. Underneath a short flange for fitting the vessel.

Ø 8.1 cm. Red, green, brown marbled. No. So III B 689. FS. 2 V 5.0/Cb 5.0, H. 19.10 m. Early Kṣatrapa. L.24

11. Fragmentary casket with lid. Shallow vessel with slightly conical wall and protruding base. Rhomboid incisions, lid decorated with concentric lines running along the edge and the elevated central knob.

Ø 5.4 cm. H. 2.5 cm (with lid). Grey-black slate. No. So III B 756. FS. 3 I 2.4/Ca 10.6, H. 20.15 m. Kṣatrapa. L.23

12. Lid of a steatite casket with conical top terminating in an elevated knob. Surface decorated with one chamfered line along the edge and numerous concentric lathe marks from edge to knob. Below, the lid is worked out for fitting some vessel.

Ø 3.7 cm. H. 1.8 cm. Colour: grey-yellow. No. So III B 718. FS. 2 III 17.0–18.5/Cc 4.5–8.5, H. 19.50–19.20 m. Kṣatrapa. L.24/23

13. Flat lid of a slate casket with central knob as handle. Finely carved. Two grooved lines along the edge form the outer border. Between the edge and the knob nine *haṃsas* are incised in succession with a loose flower near head or neck. With a few exceptions the *haṃsas* carry flower-stalks in their beaks. Around the stem of the knob an encircled floral decoration is added at the foot. The knob itself is embellished with a lotus rosette.

Ø 9.5 cm. H. 2.4 cm. Colour: grey-black. No. So I 324. FS. 2 V 1.6/Cb 16.5, H. 19.35 m. Kṣatrapa. L.23

14. Fragment of a lid from a slate casket. Surface and knob crudely decorated with scrawled incisions.

Ø 4.2 cm. H. 1.6 cm. Colour: black. No. So III B 670. FS. 2 V 0.7/Cb 14.3, H. 19.40 m. Kṣatrapa. L.13

15. Mutilated lid of a slate casket with incised lotus rosette and concentric circles on top.

Ø 3.9 cm. H. 0.95 cm. Colour: dark grey. No. So III B 658. FS. 2 V 3.0/Cc 7.9, H. 19.35 m. Kṣatrapa. L.23

16. Splintered lid of a casket decorated with a double circular line along the edge and another double line pretending a knob. Between knob and edge single incised lotus petals are visible.

Ø 3.7 cm. Grey slate. No. So III B 533. FS. 2 IV 8.4/Be 18.8, H. 21.47 m. Kuṣāṇa. L.21

17. Knob of a lid of a casket. One circular groove each along the edge and in the centre.

Ø 3.7 cm. Black polished slate. No. So III B 559. FS. 2 V 0.55/Cb 0.9, H. 20.60 m. Kuṣāṇa. L.21

18. Lid of a schist casket with central knob. Decorated with a number of single circular lines.

Ø 5.1 cm. H. 1.9 cm. Colour: grey. No. So III B 291. FS. 2 IV 11.9/Be 18.6, H. 23.45 m. Late Kuṣāṇa. L.16



1



2



3



4



5



6



7



8



9



10



11



12



13



14



1



2



3



4



5



6



7



8



9

Stone Caskets and Lids

15

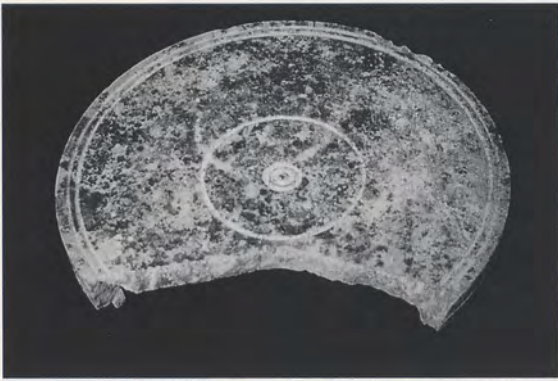

10

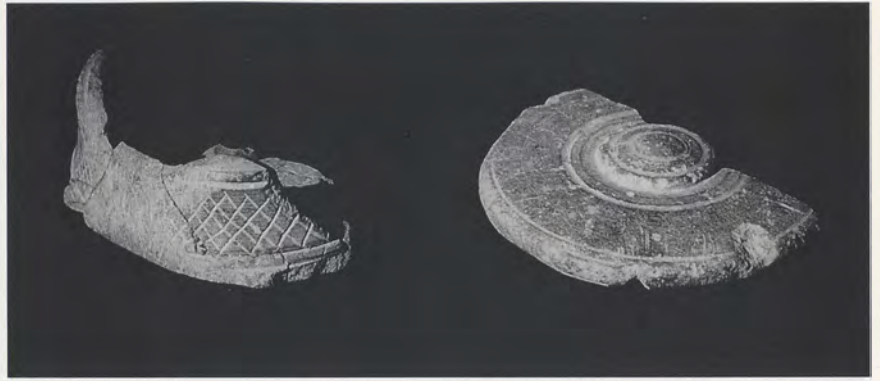

11



12



13



14



15



16



17



18

Diverse Hand-Mill Stones

In all 149 pieces of stone were recovered which have in one or the other way been used for grinding cereals by hand, serving mainly as querns, mortars, pestles and dabbers. The material is, as a rule, sandstone, mostly the mottled red Kerauli stone so well known from Mathura.

The different types of querns will be described below. The way pestles were used on the querns and in the mortar is best illustrated in nos. 11, 12 and 20 where querns and a mortar are shown found together with their pestles.

A few pieces originate from Maurya and Mitra levels, the bulk belongs to Kuṣāṇa habitations. It looks as if in the earlier levels the quern table was in fashion while in the Kuṣāṇa times the quern plate (without legs) has been favoured. The circular or rotary quern appears only in the late Kuṣāṇa to post-Gupta levels. The best preserved or otherwise significant specimens of the different types will be discussed and illustrated below.

Querns

Four main types of querns have been found: a) rectangular querns standing on legs (i.e. quern tables), b) rectangular plates without legs, c) circular stones (i.e. rotary querns), and d) architectural pieces reused as querns.

a) Quern Tables

1. Fragment of a quern table preserving one conical shaped leg and part of the slightly sloping working plate. The earliest specimen of a quern found at Sonkh.

Size: 15.8 × 14.4 × 12.1 cm. Mottled red sandstone with spots of light vein.

No. So III B 500. FS. 3 II 6.0/Ca 18.3, H. 15.80 m.

Maurya. L.34

2. Quern table broken in two parts. Four irregularly tapering legs. Plate projecting beyond the legs on one of the small sides. On this projection are grooved the three symbols *indrādhvaja*, *nandyāvarta*, and *svastika* from left to right (cp. the terracotta amulet no. 1).

Size: 38.0 × 17.5 × 17.0 cm. Mottled red sandstone with light vein.

No. So III B 754. FS.2 V 8.5/Cc 6.8, H. 18.05 m.

Mitra. L.27

3. Quern table with four legs. Plate worn out and projecting on one of the small sides. On the projection traces of the symbols *indrādhvaja*, *nandyāvarta* and *svastika* from left to right.

Size: 41.0 × 19.0 × 18.1 cm. Mottled red sandstone.

No. So III B 511. FS. 3 I 4.5/Ca 6.5, H. 18.80 m.

Mitra. L.26

4. Damaged quern table with projecting plate on one of the small sides. Legs roughly worked out as stubs.

Size: 13.1 × 6.4 × 5.3 cm. Mottled red sandstone.

No. So III B 701. FS. 2 V 8.3/Cb 2.6, H. 19.05 m.

Kṣātrapa. L.24

5. Fragment of a quern table with the plate projecting on the small side. Legs worked out by cutting a round arch.

Size: 18.3 × 14.9 × 13.0 cm. Light vein of mottled red sandstone.

No. So III B 699. FS. 2 IV 13.7/Ca 7.5, H. 20.75 m.

Early Kuṣāṇa. L.22

b) Rectangular Quern Plates

6. Thick quern plate with projecting end on one of the small sides. Stone crudely hewn in analogy to the shape of the quern tables but without legs.

Size: 28.0 × 18.4 × 7.0 cm. Mottled red sandstone.

No. So III B 680. FS. 2 IV 5.6/Be 18.0, H. 19.98 m.

Mitra. L.27

7. Quern in shape of a block of stone with one tapering end. Crudely hewn in analogy to the shape of the quern tables but without legs.

Size: 19.5 × 8.7 × 7.0 cm. Mottled red sandstone.

No. So III B 706. FS.2 V 8.7/Cb 0.7, H. 19.10–18.90 m.

Mitra. L.25

8. Rectangular quern plate with cuts and dents on the working face.

27.6 × 22.2 × 5.2 cm. Red sandstone. No. So III B 543.

FS. 2 V 16.2–19.0/Ca 17.3–19.5, H. 20.20–19.90 m.

Kṣātrapa. L.23

9. Fragment of a quern plate with roughened surface.

26.5 × 27.0 × 5.5 cm. Buff sandstone. No. So III B 671.

FS. 2 V 7.7/CB 1.5, H. 19.82 m. Kṣātrapa. L.23

10. Fragment of a slightly curved quern plate. Roughened surface.

18.5 × 15.0 × 5.2 cm. Kerauli sandstone. No. So III B 736.

FS.2 IV 0.5–9.3/Ca 19.2-Cb 0.5, H. 21.60–21.40 m.

Kuṣāṇa. L.21

11. Rectangular quern plate and pestle found together. Pestle ovoid in section.

Size: Plate 35.0 × 18.5 × 5.9 cm. Pestle L.22.0 cm. Mottled red sandstone.

No. So III B 465 + 466. FS.2 V 4.5/Cc 2.7, H. 21.90 m.

Kuṣāṇa. L.19

12. Rectangular quern plate and pestle with curved ends. Both pieces found together at the same spot as no. 11. Pestle plano-convex in section.

Size: 47.0 × 24.5 × 5.7 cm. Pestle L.33.0 cm. Mottled red sandstone with light vein.

No. So III B 467 + 468. FS.2 V 4.5/Cc 2.7, H. 21.90 m.

Kuṣāṇa. L.19

c) Rotary Querns

13. Mill wheel with central perforation and a hole near the edge for insertion of a handle. Upper part of hand-mill.

Ø 38.5 cm. Th. 4.0 cm. Mottled red sandstone.

No. So III B 226. FS. 2 IV 8.0/Ca 5.2, H. 24.20 m.

Gupta. L.15

14. Mill wheel with central hub on one side and perforation near the edge for insertion of a handle. Upper part of hand-mill.

Ø 40.5 cm. Th. 4.0/5.0 cm. Mottled red sandstone.

No. So III B 138. FS. 2 V 10.5/Ca 15.5, H. 24.60–24.35 m.

Early Medieval. L.13

15. Mill wheel with conical hub. Lower part of hand-mill.

Ø 35.0 cm. Th. 6.3 cm. Kerauli sandstone. No. So III B 212.

FS. 2 IV 4.0/Ca 11.7, H. 24.30 m. Gupta. L.15

16. Fragment of a roller mill in shape of the upper part of a jar with rim but solid with central perforation.

18.0 × 14.3 × 13.6 cm. Grey sandstone. No. So III B 339.
FS. 2 C 9.5–10.5/Cc 0.5–9.3, H. 23.02–22.62 m.
Late Kuṣāṇa. L.16

d) Architectural pieces reused as Querns

A number of architectural pieces like coping-stones, pillars and sculptures have been misused for grinding purposes. As these “querns” have no special characteristics other than dents in the stone, one selected piece may illustrate this group.

17. Architectural piece reused as quern.
10.0 × 14.0 × 5.0 cm. Grey sandstone. No. So III B 236.
FS. 2 IV 2.4/Be 18.5, H. 23.75 m. Late Kuṣāṇa. L.16

Mortars

18. Fragment of a mortar preserving the polished inner side of the mortar-bowl. Judging from the depth of the bowl and the size of the piece it seems to be part of a mortar in the shape of nos. 19–20.

Size: 22.0 × 15.5 × 17.7 cm. Mottled red sandstone.
No. So III B 662. FS. 2 V 3.5/Ca 2.5, H. 19.60 m.
Kṣātrapa. L.24

19. Two pieces of a conical mortar. The rough outer side indicates that it was placed in the earth. The smaller piece is part of the pointed end.

Size: 40.0 × 31.5 × 30.0 cm. Mottled red sandstone.
No. So III B 742 + 743. FS. 2 V 19.9/Cc 0.8, H. 20.55 m.
Kuṣāṇa. L.21

20. Complete mortar and pestle with two curved ends. Found together. Conical shape and rough outside proves that the object had to be embedded in the ground to make it workable.

Size: 50.0 × 25.5 × 25.0 cm. Pestle L.27.0 cm. Mottled red sandstone.
No. So III B 260. FS. 2 IV 5.5/Ca 3.5, H. 23.50 m.
Late Kuṣāṇa. L.16

21. Fragment of a larger stone with two mortar-holes.

Size: 57.1 × 38.0 × 16.5 cm. Mottled red sandstone.
No. So III B 92. FS. 2 IV 10.5/Ca 7.0, H. 26.30 m.
Jāt. L.7

22. Large mortar cut as a rectangular block, decorated with squarely incised lines framing the mortar-hole.

Size: ? Red sandstone. No. So III B 61.
FS. 2 V 0.5/Ca 19.2, H. 26.60 m. Jāt. L.5/4

23. Mortar-bowl with rough outer side.

Ø 34.7 cm. Grey sandstone. No. So III B 42.
FS. 7.8/Ca 9.2, H. 26.60 m. Jāt. L.5/4

Pestles and Dabbers

Of the objects used for grinding or crushing 79 are pestles or dabbers. As such implements have no standardized shapes they are quite different in make. A number of pieces from various levels have been selected to illustrate this group.

24. Irregularly cylindrical pestle.
L. 11.6 cm. Ø 4.0 cm. Kerauli stone. No. So III B 700.
FS. 2 V 11.9/Cb 3.0, H. 18.80 m. Mitra. L.25

25. Dabber with bulgy knob, dividing the piece in two nearly equal halves.

Ø 5.8 cm. H. 6.1 cm. Red sandstone. No. So III B 424.
FS. 3 I 11.0/Ca 14.0, H. 19.17 m. Mitra. L.25

26. Pestle, lenticular in section.

20.0 × 6.5 × 4.3 cm. Grey-red sandstone. No. So III B 632.
FS. 2 IV 4.7–10.5/Be 16.7–17.7, H. 20.85–20.58 m.
Kṣātrapa. L.24

27. Long pestle with thickened ends. Plano-convex in section.
L. 37.5 cm. Red sandstone. No. So III B 597.
FS. 2 V 5.5/Cb 6.5, H. 20.55 m. Early Kuṣāṇa. L.22

28. Short pestle or dabber, presumably used also as hammer-stone. Lenticular in section.

Ø 5.1 cm. L. 8.6 cm. Grey sandstone. No. So III B 722.
FS. 2 IV 9.7/Ca 2.0, H. 21.35 m. Early Kuṣāṇa. L.22

29. Short pestle; nearly circular in section. Rounded ends.

Ø 2.6 cm. L. 6.0 cm. Red sandstone. No. So III B 586.
FS. 2 V 0.5–9.5/Cb 9.5–10.5, H. 21.53–21.22 m.
Kuṣāṇa. L.21

30. Pestle or dabber of irregularly conical shape with truncated top.

H. 5.5 cm. Red sandstone. No. So III B 323.
FS. 2 V 2.0/Cb 4.5, H. 22.30 m. Kuṣāṇa. L.19

31. Pestle, slightly increasing in thickness from one end to the other. Ovoid in section.

11.6 × 6.7 cm. Mottled red sandstone. No. So III B 421.
FS. 2 IV 7.2/Ca 11.0, H. 22.50 m. Kuṣāṇa. L.19

32. Dabber with constricted neck, flat knob and rounded body.

H. 5.7 cm. Reddish sandstone. No. So III B 324.
FS. 2 V 2.5/Cc 2.3, H. 22.60 m. Late Kuṣāṇa. L.17/16

33. Pestle; circular in section.

Ø 6.5 cm. L. 17.7 cm. Mottled red sandstone.
No. So III B 268. FS. 2 IV 0.5/Cb 5.5, H. 23.10 m.
Late Kuṣāṇa. L.16

34. Conical pestle nearly circular in section.

L. 10.0 cm. Ø 2.5/3.5 cm. Mottled red sandstone.
No. So III B 176. FS. 3 I 3.0/Ca 11.3, H. 23.20 m.
Late Kuṣāṇa. L.16

35. Long pestle; circular in section.

Ø 6.5 cm. L. 26.3 cm. Mottled red sandstone.
No. So III B 112. FS. 2 IV 9.15–9.4/Ca 11.5, H. 25.45 m.
Medieval. L.11

Balls

The excavation yielded 97 balls of stone. They are made of sandstone or quartzite and, with a few exceptions are all of spherical shape. In size they range from 1.8 to 11.0cm in diameter, but more than half of them measure between 3.0 and 4.9 cm. The distribution is as follows

1.8– 1.9 cm = 9 balls	5.0– 5.9 cm = 8 balls
2.0– 2.9 cm = 15 balls	6.0– 6.9 cm = 3 balls
3.0– 3.9 cm = 29 balls	7.0– 7.9 cm = 2 balls
4.0– 4.9 cm = 34 Balls	10.1–11.0 cm = 1 ball

The smallest balls (1.8–1.9 cm) have been found only in levels of Periods V to VII while the bulk of the 3.0 to 4.9 cm specimens occurs in all levels. The weight of balls does not reveal any system. The function of such balls has often been discussed. The most convincing conclusion has been drawn by Sankalia (1971, pp. 332ff.), who argues that these balls “are almost certainly sling balls” (for killing birds and hunting animals). But this must not have been the only utilization of so practical an object as a stone ball.

The photograph of a collective find of eleven stone balls may illustrate this group of objects.

1. Eleven stone balls of different size.
Ø from 1.8 to 10.9 cm. Sandstone and quartzite.
No. So III B 28. FS. Filling in 2 IV/Cb.

*Other Stone Implements**a) Ring-stones*

1. Oblong ring-stone with rough surface, hole seems to have been bored from both sides.

15.4 × 8.6 × 5.0 cm. Grey sandstone. No. So III B 659.
FS. 2 V 5.8/Ca 19.7, H. 20.15 m. Kṣatrapa. L.24/23

2. Circular ring-stone, perforated from both sides.

Ø 3.1 cm. Grey sandstone. No. So III B 688.
FS. 2 III 16.7/Cb 6.5, H. 21.68 m. Kuṣāṇa. L.21/20

3. Circular ring-stone, perforated from both sides. Scratches along edges of hole.

Ø 3.2 cm. Grey sandstone. No. So III B 475.
FS. 3 I 2.0/Ca 9.8, H. 20.74 m. Kuṣāṇa. L.22

b) Hammer stones

4. Roundish hammer stone with flattened top and base. Ridges of harder vein of stone.

Ø 7.7 cm. Mottled red sandstone. No. So III B 170.
Trench 4 (2 I/Bd), H. 16.20 m. PGW. L.39

5. Flat oval hammer stone with rounded edges.

Ø 6.4 cm. Colour: dark grey. No. So III B 549.
FS. 2 V 10.5/Ca 9.5, H. 19.88 m. Kṣatrapa. L.24

6. Roller-shaped hammer stone or anvil. Longish dent on top, round depressions (made by use) on the sides.

Ø 5.1 cm. L. 7.4 cm. Mottled red sandstone.
No. So III B 23. FS. Tower, between mud-brick walls.
Medieval. L.11

7. Hammer stone of roundish shape with flattened top and bottom. Strong traces of use.

Ø 4.6 cm. H. 3.2 cm. Kerauli stone. No. So III B 137.
FS. 2 V 14.0–18.0/Ca 8.0–9.5, H. 25.44–25.00 m.
Medieval. L.11

c) Discs

Altogether 20 discs of different thickness, mostly of Kerauli stone. Four specimens may stand for all.

8. Stone disc; surface partly chipped off.

Ø 3.9 cm. Dark violett sandstone. No. So III B 553.
FS. 3 I 4.0/Ca 11.2, H. 18.00 m. Mitra. L.27

9. Worn stone disc.

Ø 4.9 cm Th. 1.4 cm. Mottled red sandstone.
No. So III B 399. FS. 2 IV 2.0/Be 18.0, H. 21.90 m.
Kuṣāṇa. L.21/20

10. Thick stone disc with roughened surface.

Ø 6.5 cm. Th. 3.2 cm. Mottled red sandstone.
No. So III B 503. FS. 2 IV 0.5/Ca 17.7, H. 22.15 m.
Kuṣāṇa. L.20/19

11. Stone disc with flat top and base; smooth surface.

Ø 3.9 cm. Th. 1.4 cm. Mottled red sandstone.
No. So III B 390. FS. 2 V 2.0/Cc 6.0, H. 22.37 m.
Late Kuṣāṇa. L.17/16

Diverse Stone Objects

1. Flat stone pendant of conical shape with rounded top. Perforation near upper edge.

H. 3.8 cm. Grey slate. No. So III B 708.
FS. 2 IV 7.9/Be 18.0, H. 16.46 m. Maurya. L.35/34

2. Flat stone pendant of conical shape with rounded top. One perforation near the top, a second, vertical hole from the upper edge meeting the perforation channel.

H. 4.0 cm. Th. 1.2 cm. Grey-green stone. No. So III B 504.
FS. 3 I 4.0/Ca 17.5, H. 20.35 m. Kṣatrapa. L.23

3. Rectangular block of stone with one roughened side. Whetstone?

5.8 × 5.2 × 3.7 cm. Red sandstone. No. So III B 683.
FS. 2 V 8.2/Ca 6.7, H. 18.90–18.75 m. Mitra. L.26

4. Stylus with two pointed ends.

4.2 × 0.75 × 0.4 cm. Grey slate. No. So III B 681.
FS. 2 IV 6.0/Be 16.0, H. 20.48 m. Kṣatrapa. L.23

5. Conical stone object with central perforation.

H. 5.5 cm. Grey sandstone. No. So III B 472.
FS. 2 V 17.7/Ca 10.5, H. 21.90 m. Kuṣāṇa. L.20

6. Small stone object. Head on stand? One-sided. Gamesman?

H. 2.8 cm. B. 2.1 cm. Grey sandstone. No. So III B 167.
FS. 2 IV 10.5/Ca 10.5, H. 25.20 m. Medieval. L.12

7. Fragment of a round stand with legs. Rimmed surface decorated with geometrical pattern.

Ø 18.0 cm. Grey sandstone. No. So III B 205.
FS. 2 V 10.3/Ca 15.7, H. 24.85 m. Medieval. L.11

8. Stone bowl with slightly curved rim. Outer and inner sides showing traces of treatment.

Ø 20.4 cm. H. 8.9 cm. Mottled red sandstone. No. So I 63.
FS. 2 IV 14.2/Ca 16.9, H. 26.75 m. Jāt. L.4

9. Fragment of a stone bowl decorated with lotus petals overlapping each other on the outer side.

Ø 18.8 cm. H. 9.9 cm. Mottled red sandstone. No. So I 49.
FS. 2 V 8.5/Ca 12.0, H. 28.00–27.70 m. Modern.



1



2



3



4



5



6

Hand-Mill Stones



7



8



9



10



11



12



13



14



15



16



17



18

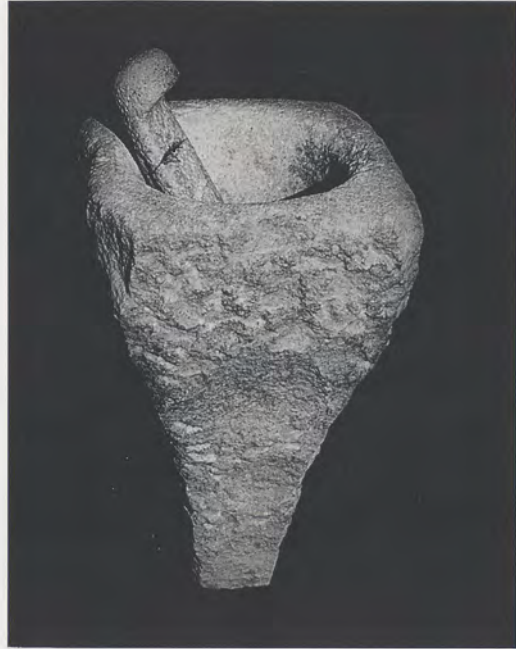

20



19



21



22



23

16



24

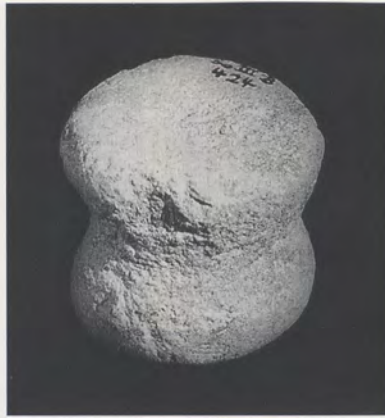

25



26



27

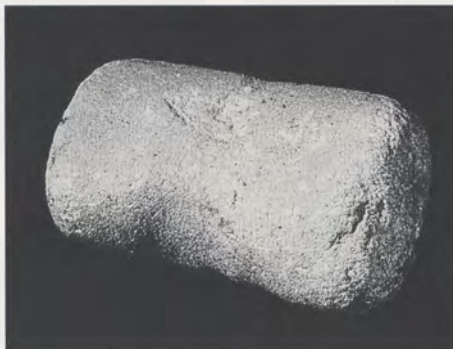

28



29



30



31



32



33

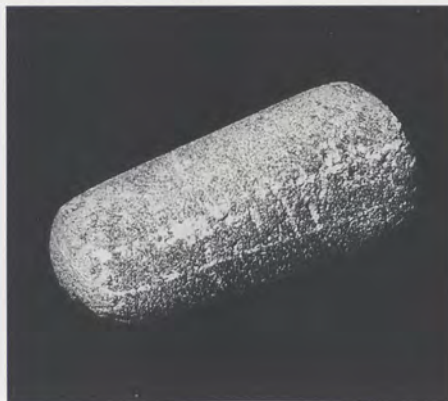

34



35



1



1



2



3

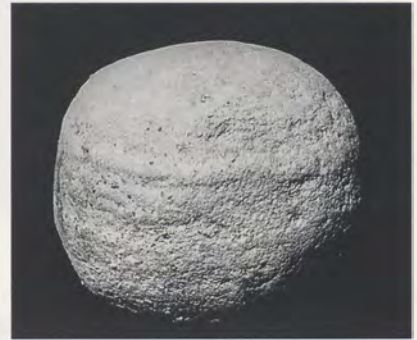

4



5

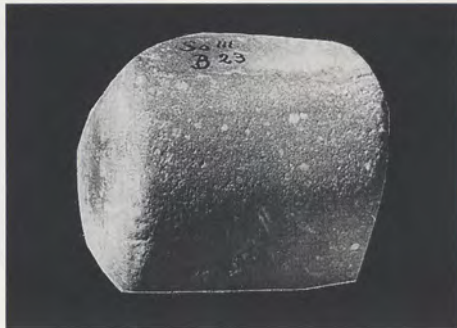

6

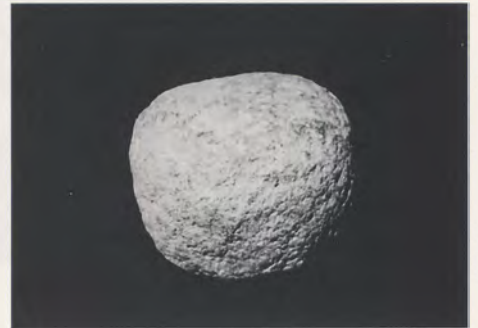

7



8



9



10



11

Stone Balls (1); Other Stone Implements (1-11)



1



2



3



4



5



6



7



8



9

C. OBJECTS OF BONE, SHELL, GLASS AND IVORY

Not less than 774 objects of these materials have been registered as finds from various levels at Sonkh. A large number of them are tiny and insignificant fragments from the latest Period VIII unqualified for studies. Good condition show the objects made of bone among which the group of 203 styli is by far the largest. More fragmentary are the altogether 349 fragments of mostly plain shell bangles so abundantly found in the Mitra and Kuṣāṇa levels. Bangles of glass are astonishingly rare in Sonkh and only present in tiny fragments from the latest levels. Beads of bone, shell, glass and ivory have been discussed in the chapter BEADS. Special attention has to be paid to the group of styli already mentioned. They were recovered from levels 28 to 19, i.e. Mitra to Kuṣāṇa times. The bulk of them measures between 6.0 and 9.0 cms. A selection of specimens will illustrate the types, hereby showing that the early Kuṣāṇa styli seem to be the most carefully made.

Styli

a) Styli of Period III. Levels 28 to 24

1. Two styli from level 28. L. 7.78 and 6.57 cm. Nos. So III D 901; 883
2. Six roughly made styli from level 27. L. 7.45 to 5.05 cm. Nos. So III D 999; 975; 1015; 993; 1006; 997; 1003; 1046.
3. Twelve styli of mostly single-pointed type, from level 27. The fourth from right being rather a hair-pin or antimony rod with rounded ends. L. 12.1 to 7.6 cm. Nos. So III D 876; 1000; 1048; 1049; 947; 1010; 1053; 948; 986; 1005; 996; 949.
4. Seven styli, partly broken, from level 26. L. 11.2 to 5.3 cm. Nos. So III D 911; 976; 892; 977; 905; 989; 990.
5. Six styli from level 25. L. 11.4 to 5.9 cm. Nos. So III D 930; 895; 896; 839; 929; 917.

b) Styli of Periods IV–V. Levels 23 to 19

6. Fourteen more carefully carved double-pointed styli from level 23. L. 12.3 to 6.6 cm. Nos. So III D 970; 877; 894; 959; 893; 885; 942; 941; 878; 909; 936; 934; 887; 944.
7. Seven finely made double-pointed styli. Level 22. L. 8.6 to 5.8 cm. Nos. So III D 953; 951; 925; 952; 874; 973; 899.
8. Four rough specimens of styli from levels 21/19. L. 10.5 to 6.5. Nos. So III D 891; 931; 1045; 1028.

Hair-pins

9. Fragment of a broken hair-pin with pinhead. L. 5.2 cm. No. So I 380. Maurya. L.33
10. Slender, finely shaped undecorated hair-pin (or antimony rod?) with thickened rounded ends. L. 8.7 cm. No. So III D 828. Early Kuṣāṇa. L.22
11. Conical shaped hair-pin with top richly decorated by incisions. L. 8.5 cm. No. So I 174. Kuṣāṇa. L.20

Miscellaneous Bone Objects

12. Fragmentary anthropomorphic figure of bone with incised lines and circlets. A comparison with more complete pieces found at Prabhas Patan and other places makes it obvious that the find from Sonkh represents the lower part of a human, probably female, figure to be supplemented on top by two horizontally arranged arms and a triangular face. Such pieces may have been used as amulets.

H. 5.5 cm. Th.0.3 cm. Bone. No. So I 382.
FS. 2 IV 9.3/Cc 8.8, H. 15.70 m. Maurya. L.33

13. Longish die of bone with number 1 to 4 indicated by incised circles consisting of two concentric orbs with a hole in the centre. At the ends the die is bordered by three incised lines running along the four sides.

Size: 8.65 × 1.9 × 1.9 cm. Bone. No. So I 305.
FS. 2 V 0.5/Cc 7.0, H. 19.60 m. Kṣātrapa. L.23

14. Longish die of bone similar to no. 13. The numbers 1 to 4 indicated by incised circles with central hole which itself is encircled by five smaller circles with own hole. At the ends four incised lines with a band of punched circles between the two last border-lines.

Size: 9.4 × 1.6 × 1.7 cm. Bone. No. So I 319.
FS. 2 V 7.4/Cb 17.0, H. 19.50 m. Kṣātrapa. L.23

15. Fragment of a conical bone object, inside hollow, outside decorated with seven bands of three incised lines each.

H. 6.5 cm. Ø 2.2/1.6 cm. Bone. No. So I 284.
FS. 2 V 8.7/Ca 16.8, H. 19.25 m. Mitra. L.25

16. Bowl of shell with two copper nails on one and a third nail on the opposite side.

7.9 × 7.5 × 2.2 cm. White with brown. No. So I 192.
FS. 3 II 8.2/Ca 13.5, H. 19.20 m. Mitra. L.25

17. Fragment of a shell bangle decorated with horizontally incised lines and two jewel-shaped projections.

Size: 6.4 × 1.4 cm. White shell. No. So III D 965.
FS. 2 IV 6.0/Cb 19.5, H. 22.00 m. Kuṣāṇa. L.18

18. Small ivory comb with teeth on both sides. 16 teeth missing. 5.8 × 4.6 cm. Colour: yellowish brown. No. So I 54.

FS. 2 V 3.6/Ca 13.25, H. 27.15 m. Jāt. L.4

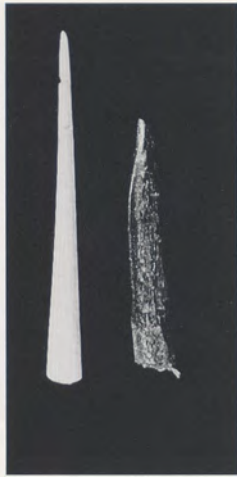

1



2



3



4



5

IX. METAL IMAGES

The first of these images is a long, thin, pointed object, possibly a bone needle or a similar tool, shown in profile against a dark background.



6. A row of 15 small, pointed bone objects, likely needles or pins, arranged horizontally against a black background.



7. A row of 8 small, pointed bone objects, similar to those in image 6, arranged horizontally against a black background.

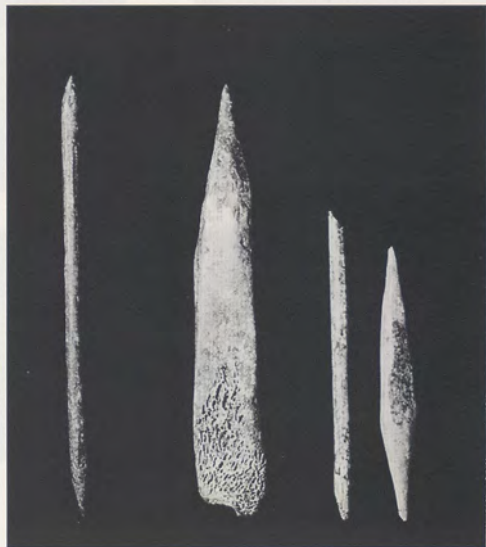

8. A group of four bone objects: one long and thin, one larger and wider with a textured surface, and two smaller pointed objects, all against a black background.



9. A single bone object with a rounded, textured head and a long, thin shaft, shown horizontally against a black background.



10. A single long, thin bone object, possibly a needle or pin, shown diagonally against a black background.



11



12



12R

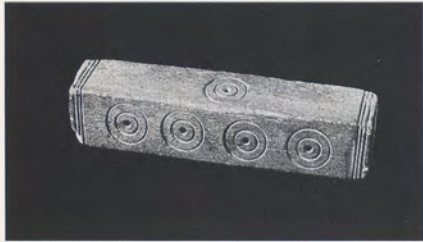

15

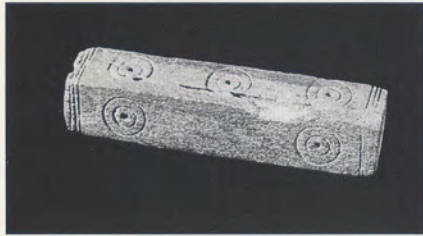

13



14



16



17

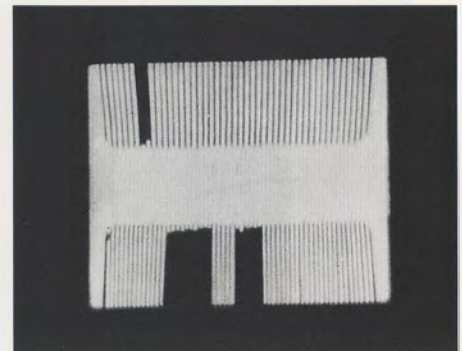

18

D. METAL IMAGES

The art of Mathura, so excessively represented by the works in stone and terracotta, has not handed down so far a single metal image of the Kuṣāṇa or any other period with certainty. There is one little female figure which might be seen as a product of the Mathura School, but it is of unknown findplace and, therefore, not furnishing safe proof for the existence of this branch of art in early Mathura (cp. P. K. Agrawala, 1977, pp. 65 ff., fig. 137, and Czuma/Morris, 1985, pp. 104 f., fig. 38). Fortunately, the Sonkh excavations yielded two small bronze figures which, although no masterly specimens, are to our knowledge the first Mathura metal images found in stratified levels of the Kuṣāṇa period.

1. Standing figure of Skanda. Flatly cast bronze in two pieces joined together. The god stands in frontal posture on a low pedestal with a clean end on the left and a fracture on the right side. With his raised right hand he holds the attribute *śakti* the shaft of which ends in a knob near to the right knee. The straight vertical double line below it is a piece of frame. Skanda's left hand is placed akimbo. He wears a tall diadem with large central jewel, rings in both (?) ears and a one-stringed pearl necklace (*ekāvalī*). The garment is arranged in folds and covers both legs down to the knees, it is kept by a two-stringed girdle, not a waistband, gathered around the hips. The projection on the left hip is therefore not a waistband-knot but presumably the connecting bar towards a further figure broken away now. This hypothesis would be supported by the bar's crude make, by the bulge at the elbow of the left arm which might be one more point of contact with a neighbouring figure (cp. no. 2), and by the fact that the pedestal does not have an end on the right side. In this case the god should be identified as the Skanda of a three-figured Śaṣṭhī relief. On the other hand, Skanda holds the *śakti* in his left hand which is only the case when he is accompanied by his favourite bird, the cock. Therefore P. K. Agrawala (1977, p. 63) would like to see a tiny cock on the left hand side. The back of the bronze is hollow.

H. 9.3 cm. Colour: green patina. No. So I 178.
FS. 2 IV 15.5/Ca 8.9, H. 22.40 m. Kuṣāṇa. L. 19

2. Standing divine couple. Flatly cast bronze. The couple stands in frontal posture on a low pedestal within a frame of columns and an architrave made up of double rods. The *torāṇa* impression of this frame is strengthened by S-shaped brackets in the triangle between pillar and lintel on both sides and by a central ornament consisting of a ring below and a tripartite symbol above the beam looking like the separated parts of a *nandyāvarta*.

The figures, joined to each other as well as to the frame by small bars, are those of a man and a woman, the male figure being much taller than the female. The woman, dressed in a short garment, has an animal head with large, round eyes and ears; there is a damaged spot near the mouth. As far as preserved, hair is bristling around the head. Her right arm is bent upwards holding the hand with its palm turned inwards (*vyāvṛta mudrā*). He raises his right arm and holds the hand up with its palm even more clearly turned inwards than with the woman. In the left suspended hand he carries a bowl. He is dressed in a dhotī, the knotted end of which is visible in folds between the legs. A broad necklace runs from shoulder to shoulder. His hair appears to be piled up high (*jaṭāmukuta*) and is decorated with a diadem. He may have been intentionally depicted with only one ear-ring (*ekakuṇḍala*), but it is also possible that the right ear's ornament has been broken off.

While the female can be made out as a cat-shaped Mother goddess, the male figure is, for want of specific attributes, difficult to identify. Nevertheless, his appearance by the side of an animal-headed Mother goddess in this relief connects him with great probability with Skanda. The author thinks along the same lines as P. K. Agrawala (1977, p. 64) who comes through the interpretation of the feline figure to the conclusion: "*From the iconographic evidence provided by some contemporary stone plaques from Mathura itself and by certain texts, we have no doubt this goddess is Carcikā-Śaṣṭhī, a mother goddess presiding over childbirth and assimilated with Devasenā-Śaṣṭhī, the spouse of Skanda*".

H. 10.6 cm, W. 8.5 cm. Colour: green patina.

No. So I 173. FS. 2 IV 9.5/Ca 0.10, H. 24.28 m.

Kuṣāṇa. In house C of L. 16. Presumably surviving from an earlier Kuṣāṇa level.

E. METAL OBJECTS

In all 571 metal objects have been found. The metals are copper, iron, lead and brass. Those of copper and iron appeared through all the Periods, objects of lead and brass occurred from level 27 onwards. The finds comprise weapons, tools, other implements, household and ornamental objects. Beads of metal have been described elsewhere (see chapter BEADS).

A large number of metal objects, esp. those of iron, are either shapeless or indeterminate. But there remains a comparatively large number of finds to be listed here. It seems advisable not to describe weapons, tools etc. collectively but to present the material according to their appearance in the successive Periods. Therein, however, the objects will be grouped subjectwise.

Period I. Objects from Levels 40 to 37

1. Arrow-head, barbed, with socket.
L. 6.3cm. Iron. So III C 537.
FS. 2 IV/Cc, H. 13.10–12.80m. PGW
2. Arrow-head, lanceolate, tanged.
L. 4.0cm. Iron. So III C 55.
FS. 3 I/Ca, H. 14.95–14.85m. PGW
3. Arrow-head, barbed, tanged.
L. 7.6cm. Iron. So III C 321.
FS. 3 I/Ca, H. 14.85–14.75m. PGW
4. Fragment in shape of the blade of an adze or axe.
Size: 2.8 × 2.7 cm. Iron. So III C 54.
FS. 3 I/Ca, H. 15.25–15.15m. PGW

Period II. Objects from Levels 36 to 29

5. Arrow-head, lanceolate, tang missing.
L. 3.9cm. Iron. So III C 270.
FS. 3 II/Ca, H. 15.75–15.45m. Early Maurya. L.35
6. Arrow-head with long barbs, socket(?).
L. 5.5cm. Iron. So III C 534.
FS. 2 IV/Cc, H. 16.05–15.90m. Maurya. L.32
7. Triangular flat object.
Size: 7.3 × 4.8 cm. Iron. So III C 98.
FS. 3 II/Ca, H. 16.30–16.00m. Maurya. L.33
8. Rod.
L. 31.2cm. Iron. So III C 554.
FS. 2 IV/Cc, H. 14.35–14.20m. Early Maurya. L.36
9. Fork, seven-pronged.
L. 8.6cm. Copper. So I 369.
FS. 2 IV/Cc, H. 15.73m. Maurya. L.33
10. Nail with broad circular head.
L. 9.9cm. Iron. So III C 93.
FS. 3 I/Ca, H. 16.85–16.60m. Maurya. L.32
11. Mutilated bracelet, exterior concave.
Diam. 6.2cm. H. 1.6cm. Copper. So I 379.
FS. 2 IV/Cc, H. 15.85m. Maurya. L.32

Period III. Objects from Levels 28 to 25

12. Arrow-head, barbed, hollow tang.
L. 5.8cm. Iron. So III C 549.
FS. 2 III/Cc, H. 18.55–18.35m. Mitra. L.26

13. Arrow-head, lanceolate, solid tang.

L. 5.3cm. Iron. So III C 247.
FS. 2 V/Ca, H. 19.20–19.00m. Mitra. L.26/25

14. Arrow-head, slender, square section.

L. 7.0cm. Iron. So III C 498.
FS. 2 V/Cb, H. 18.95–18.80m. Mitra. L.25
Note: One more specimen registered as So III C 86

15. Lanceolate object with two lobes at one end.

L. 7.3cm. Iron. So III C 408.
FS. 2 V/Cb, H. 18.35–18.20m. Mitra. L.27

16. Fragment of a spear-head, tang missing.

L. 13.8cm. Iron. So III C 430.
FS. 2 IV/Be, H. 19.55m. Mitra. L.27
Note: 2 more specimens registered under So III C 490; 493.

17. Sickle.

Size: 24.8 × 17.4cm. Iron. So III C 340.
FS. 2 V/Ca, H. 18.70m. Mitra. L.26.
Note: 4 more specimens under So III C 85; 271; 429; 512.

18. Rod.

L. 28.4cm. Iron. So III C 557.
FS. 2 V/Cc, H. 18.40–18.27m. Mitra. L.26

19. Brand-iron showing mutilated nandyāvarta symbol.

L. 32.2cm. H. 13.6cm. Iron. So III C 156.
FS. 3 I/Cb, H. 18.80m. Mitra. L.26

20. Coil. *Found together with no. 19.*

L. 13.0cm. Diam. 5.1cm. Iron. So III C 157.
FS. 3 I/Cb, H. 18.80m. Mitra. L.26

21. Buckle, circular, with remnants of bridge and tongue.

Diam. 4.7cm. Iron. So III C 274.
FS. 2 V/Ca, H. 18.90–18.70m. Mitra. L.26

22. Thick nail with broad stubby head.

L. 7.9cm. Diam. of head 2.8cm. Iron. So III C 409
FS. 2 V/Cb, H. 18.95–18.70m. Mitra. L.25

23. Fragment of a nail with broad circular head.

L. 2.4cm. Diam. of head 2.3cm. Iron. So III C 120.
FS. 3 I/Ca, H. 18.55–18.20m. Mitra. L.27/26

24. Fragment of a nail with broad square hat-like head.

L. 2.6cm. Diam. of head 2.5cm. Iron. So III C 121.
FS. 3 I/Ca, H. 18.55–18.20m. Mitra. L.27/26

25. Four rectangular hooks (bent nails).

L. 1.9cm. Copper. So III C 370.
FS. 2 V/Ca, H. 19.20m. Mitra. L.25

26. Mutilated big copper pan with handles and thorns.

Diam. ca. 30.0cm. Copper. So I 124.
FS. 3 I/Ca, H. 17.20m. Early Mitra. L.28

27. Toggle, lancet-shaped.

Size: 1.7 × 0.3cm. Copper. So III C 128.
FS. 2 V/Ca, H. 18.58–19.30m. Mitra. L.25

28. Two eight-shaped wire objects (parts of chain?).

L. 1.5cm. W. 0.8cm. Copper. So III C 356.
FS. 3 I/Ca, H. 18.76m. Mitra. L.26

29. Ring.

Diam. 1.8cm. Iron. So III C 499.
FS. 2 V/Cb, H. 18.10–17.94m. Mitra L.27
Note: 3 more rings registered under So III C 237; 561; 562;

- 19
30. Ring, much corroded.
Diam. 2.4 cm. Copper. So III C 464.
FS. 2 V/Ca, H. 19.45 m. Mitra. L.25
31. Bracelet, much corroded.
Diam. 6.5 cm. H. 2.6 cm. Iron. So III C 189.
FS 3 I/Ca, H. 19.90–19.60 m. Mitra. L.25
Note: One more fragment cp. So III C 482.
32. Antimony rod, deformed, round club ends.
L. 7.7 cm. Brass or copper. So III C 422.
FS. 2 IV/Cc, H. 17.50 m. Mitra. L.27
Note: 3 more specimens registered under So III C 522; 523; 524.
33. Antimony rod, rounded ends, middle part thinner than the ends.
L. 11.2 cm. Copper. So III C 478.
FS. 2 V/Cb, H. 18.10 m. Mitra. L.27
Note: 13 more specimens registered under So III C 53; 352; 359; 379; 413; 414; 423; 424; 437; 451; 475; 511; 514.
34. Reel-shaped disc made of coiled strip (ear-stud?).
Diam. 2.8 cm. Lead. So III C 517.
FS. 2 IV/Cc, H. 17.95–17.80 m. Mitra. L.27/26
Note: 3 more fragments registered under So III C 404; 474; 548.
35. Concave disc made of tightly coiled strip (ear-stud?).
Diam. 2.3 cm. H. 1.6 cm. Lead. So III C 381.
FS. 2 IV/Cc, H. 18.10–17.95 m. Mitra. L.26
36. Concave disc made of coiled strip.
Diam. 2.7 cm. Lead. So III C 405.
FS. 2 V/Cb, H. 18.60 m. Mitra. L.26
Note: 11 more specimens under So III C 306; 308; 311; 312; 316; 386; 396; 400; 401; 403; 515.
37. Fragment of a bracelet, exterior concave.
Diam. 4.0 cm. Brass. So III C 421.
FS. 2 V/Cb, H. 18.00 m. Mitra. L.27
38. Fragment of a bangle.
L. 5.7 cm. Brass. So III C 373.
FS. 3 I/Ca, H. 18.40–18.10 m. Mitra. L.27
Note: 2 fragments more under So III C 425; 466.
39. Fragment of a wheel with remains of 4 spokes.
Size: 4.0 × 1.8 × 0.4 cm. Copper. So III C 544.
FS. 2 IV/Cc, H. 17.50 m. Mitra. L.27
- Period IV. Objects from Levels 24 to 23*
40. Long arrow-head, double tanged.
L. 14.7 cm. Iron. So III C 567.
FS. 2 V/Cb, H. 19.40–19.00 m. Kṣatrapa. L.24/23
Note: One more specimen under So III C 566.
41. Arrow-head, lanceolate, short tang.
L. 10.4 cm. Iron. So III C 568.
FS. 2 V/Cb, H. 19.40–19.00 m. Kṣatrapa. L.24/23
Note: One more specimen registered under So III C 222.
42. Arrow-head, barbed, socketted.
L. 4.6 cm. B. 2.5 cm. Iron. So III C 391.
FS. 2 V/Cb, H. 19.25–19.10 m. Kṣatrapa. L.24/23
43. Long spear-head, socketted, triangular blade.
L. 34.0 cm. B. 6.3 cm. Iron. So III C 354.
FS. 2 V/Cb, H. 19.10 m. Kṣatrapa. L.24
44. Knife or dagger, slightly curved.
L. 26.0 cm. Iron. So III C 136.
FS. 2 V/Ca, H. 19.77–19.47 m. Kṣatrapa. L.24
45. Knife or dagger, lanceolate blade, broad tang.
L. 19.0 cm. Iron. So III C 341.
FS. 2 V/Ca, H. 19.50 m. Kṣatrapa. L.24
46. Sickle.
Size: 25.0 × 15.0 cm. Iron. So III C 417.
FS. 2 V/Cb, H. 19.30 m. Kṣatrapa. L.23
Note: One more fragment: So III C 336.
47. Rod with globular knob.
L. 29.1 cm. Iron. So III C 91.
FS. 2 V/Ca, H. 20.35–20.05 m. Kṣatrapa. L.23
48. Curved hook-bolt.
L. 6.5 cm. Iron. So III C 313.
FS. 2 V/Cb, H. 19.60–18.85 m. Kṣatrapa. L.24/23
49. Nail with broad flat head.
Diam. 2.2 cm. L. 7.5 cm. Copper. So III C 505.
FS. 2 V/Cb, H. 19.35–19.15 m. Kṣatrapa. L.23
50. Part of a chain or harness.
L. 24.5 cm. Iron. So III C 481.
FS. 2 V/Cc, H. 19.25 m. Kṣatrapa. L.23
51. Clamp, flat shield, 2 angular prongs.
Size: 7.7 × 3.0 × 3.1 cm. Iron. So III C 484.
FS. 2 V/Cb, H. 19.40 m. Kṣatrapa. L.23
52. Tapering rod with hilt of coiled wire.
L. 25.0 cm. Iron. So III C 483.
FS. 2 V/Cb, H. 19.40 m. Kṣatrapa. L.23
53. Object in the shape of a horse-shoe with 2 braces.
Size: 10.2 × 8.8 × 5.0 cm. Iron. So III C 494.
FS. 2 V/Cb, H. 19.20 m. Kṣatrapa. L.24
54. Fragment of a harness(?) with small effigy of horse(?)
Size: 15.7 × 11.3 × 2.1 cm. Iron. So III C 564.
FS. 2 V/Cb, H. 19.10 m. Kṣatrapa. L.24
Note: Corresponding fragment from same spot under So III C 565.
55. Fragment of a spoon, part of stem missing.
Size: 13.6 × 6.1 cm. Iron. So III C 539.
FS. 2 V/Cc, H. 19.42–19.10 m. Kṣatrapa. L.23
56. Small disc.
Diam. 3.0 cm. Lead. So III C 418.
FS. 2 V/Cb, H. 19.10 m. Kṣatrapa. L.24
57. Ladle.
L. 14.1 cm. W. 4.8 cm. Iron. So III C 551.
FS. 2 V/Ca, H. 19.55 m. Kṣatrapa. L.24
58. Goblet with two bowls. Copper. No. So I 225 a-c.
a) Goblet, carinated, slightly out-curved rim, narrow stem, stepped foot. H. 17.0 cm. Diam. 13.6 cm.
b) Bowl, hemispherical. Diam. 16.0 cm. H. 4.0 cm.
c) Bowl, hemispherical. Diam. 16.0 cm. H. 4.0 cm.
FS. 2 V/Ca, H. 20.20 m. Kṣatrapa. L.23
59. Ornamental object (fragment of handle?).
Size: 3.9 × 2.3 cm. Copper. So III C 324.
FS. 2 V/Ca, H. 19.50 m. Kṣatrapa. L.24

60. Pin(?), rounded ends, same thickness all over.
L. 13.8cm. Copper. So III C 390.
FS. 2 V/Cc, H. 19.80m. Kṣatrapa. L.23
61. Antimony rod with round club-like ends.
L. 9.9cm. Copper or brass. So III C 443.
FS. 2 V/Ca, H. 19.90m. Kṣatrapa. L.23
Note: 16 more specimens registered under So III C 349; 353; 365; 376; 415; 419; 427; 436; 438; 439; 447; 452; 456; 460; 468; 516.
62. Fragment of bangle, remaining end bears grooved ornaments.
L. 9.7cm. Brass. So III C 450.
FS. 2 V/Cb, H. 18.95m. Kṣatrapa. L.24
63. Fragment of bangle, thin wire.
L. 7.4cm. Brass. So III C 375.
FS. 3 I/Cb, H. 19.60m. Late Kṣatrapa. L.23/22
Note: One more fragment: So III C 360.
64. Ring, made of wire with circular cross section; groove indicates where the tapering ends of the wire overlap.
Diam. 2.2cm. Copper. So III C 116.FS. 2 IV/Be, H. 20.80m. Kṣatrapa. L.24
65. Cog-wheel ring.
Diam. 3.8cm. Bronze. So III C 325.
FS. 2 V/Cb, H. 19.75m. Kṣatrapa. L.23
66. Corroded concave disc made of coiled strip (ear-stud?).
Diam. 2.6cm. H. 1.7cm. Lead. So III C 407.
FS. 2 V/Cb, H. 19.45–19.15m. Kṣatrapa. L.23
Note: 2 more fragments under So III C 307; 520.
67. Fragment of a bangle, flat section.
Diam. 9.0cm. H. 3.7cm. Iron. So III C 530.
FS. 2 V/Ca, H. 20.10m. Kṣatrapa. L.23
- Period V. Objects from Levels 22 to 16*
68. Arrow-head, lanceolate, (presumably) tanged.
L. 6.1cm. Iron. So III C 225.
FS. 2 IV/Cb, H. 21.75–21.55m. Kuṣāṇa. L.20
69. Arrow-head, three-edged, part of tang missing.
L. 6.2cm. Iron. So III C 305.
FS. 2 IV/Ca, H. 22.14–22.00m. Kuṣāṇa. L.20/19
70. Arrow-head, lanceolate, very long and slender, tanged.
L. 10.6cm. Iron. So III C 169.
FS. 3 I/Ca, H. 22.50–22.20m. Kuṣāṇa. L.19
Note: One more specimen of same type under So III C 272.
71. Arrow-head, triangular, with socket.
L. 10.1cm. Iron. So III C 242.
FS. 2 V/Cv, H. 23.15–22.85m. Kuṣāṇa. L.17
72. Arrow-head, barbed, with socket,
L. 7.9cm. Iron. So III C 235.
FS. 2 III/Ca, H. 24.00–23.70m. Late Kuṣāṇa. L.16
73. Arrow-head, barbed, with socket.
L. 8.4cm. Iron. So III C 52.
FS. 2 III/Cb, H. 23.79–23.50m. Late Kuṣāṇa. L.16
74. Spear-head, lanceolate, tanged.
L. 18.2cm. Iron. So III C 84.
FS. 2 III/Ca, H. 23.05m. Kuṣāṇa. L.18
Note: 7 more specimens under So III C 51; 72; 103; 145; 172; 218; 420
75. Spear-head with socket.
L. 22.9cm. Iron. So III C 90.
FS. 2 III/Ca, H. 24.30–24.00m. Late Kuṣāṇa. L.16
76. Fragment of a knife (main part of blade).
L. 10.6cm. Iron. So III C 495.
FS. 2 IV/Ca, H. 21.75–21.60m. Kuṣāṇa. L.21
77. Triangular blade with loop.
L. 8.8cm. Iron. So III C 191.
FS. 2 V/Cb, H. 21.90–21.60m. Kuṣāṇa. L.20
78. Sickle.
Size: 17.3 × 14.5cm. Iron. So III C 171.
FS. 2 IV/Ca, H. 22.77–22.57m. Kuṣāṇa. L.19/18
Note: 7 more specimens under So III C 33; 34; 35; 59; 63; 329; 411.
79. Long strap.
Size: 33.4 × 4.1cm. Iron. So III C 477.
FS. 2 IV/Cb, H. 22.55m. Kuṣāṇa. L.17
Note: 6 more fragments of straps: So III C 62; 127; 132; 176; 301; 302
80. Clamp or staple with long prongs.
L. 7.0cm. W. 6.1cm. So III C 211.
FS. 2 IV/Ca, H. 23.16–22.86m. Kuṣāṇa. L.18/17
Note: 2 more specimens with short prongs: So III C 76; 158.
81. Clamp or shackle or fitting, flat section.
Diam. 12.0cm. H. 6.5cm. Iron. So III C 117.
FS. 2 IV/Ca, H. 22.24–21.94m. Kuṣāṇa. L.20
82. Angular hook.
Size: 4.6 × 2.2cm. Iron. So III C 179.
FS. 2 V/Cc, H. 20.97–20.64m. Kuṣāṇa. L.21
Note: 6 more such hooks under So III C 109; 115; 180; 335; 398; 406.
83. Tube, one end pronged.
Diam. 2.3cm. L. 8.4cm. Iron. So III C 131.
FS. 2 IV/Be, H. 22.50–22.20m. Kuṣāṇa. L.20
Note: 3 more pieces of tube: So III C 112; 230; 258.
84. Part of a snaffle bit. Big loop at one end, short stem, small loop at the other end (resembles a modern beer-bottle opener).
L. 10.8cm. W. 6.6cm. Iron. So III C 265.
FS. 2 V/Cc, H. 20.20m. Early Kuṣāṇa. L.22
Note: one similar object registered under So III C 264.
85. Mounting.
Size: 8.0 × 3.3cm. Iron. So III C 48.
FS. 2 III/Cb, H. 22.90–22.50m. Kuṣāṇa. L.18/17
86. Irregularly shaped sheet with small hole to left.
Size: 2.1 × 1.9 × 1.2cm. Copper. So III C 463.
FS. 2 IV/Be, H. 22.37m. Kuṣāṇa. L.19
87. Fragment of a ladle (stem partially missing).
Diam. 5.1cm. H. 4.7cm. Iron. So III C 503.
FS. 2 IV/Ca, H. 20.55–20.35m. Early Kuṣāṇa. L.(23)/22
Note: One more fragment registered under So III C 346.
88. Small bowl-lid with central conical knob.
Diam. 3.5cm. H. 0.7cm. Brass. So III C 338.
FS. 2 V/Cb, H. 21.15m. Kuṣāṇa. L.20
89. Rattle bell, globular, loop on top.
Diam. 6.5cm. H. 5.7cm. Iron. So III C 416.
FS. 2 IV/Cb, H. 22.30m. Kuṣāṇa. L.18

90. Fragment of a cart, very corroded. Axle, bottom, part of left and right railing are still recognisable.
Size: 11.5 × 6.1 × 2.8 cm. Copper. So III C 388.
FS. 2 V/Ca, H. 20.65 m. Early Kuṣāṇa. L.22
91. Thin circular disc with hole near edge.
Diam. 1.5 cm. Copper. So III C 88.
FS. 3 I/Cb, H. 22.47–22.37 m. Kuṣāṇa. L.18
92. Antimony rod with rounded and thickened ends.
L. 8.8 cm. Copper. So III C 38.
FS 2 IV/Cb, H. 23.43–23.13 m. Kuṣāṇa. L.17/16
Note: 10 more = So III C 27; 347; 351; 364; 374; 435; 440; 459; 471; 473
93. Pin (or antimony rod) with pointed and thickened ends.
L. 16.3 cm. Copper. So III C 26.
FS. 2 III/Ca, H. 23.30–23.00 m. Kuṣāṇa. L.19/18
Note: 8 more pins under So III C 30; 31; 37; 358; 366; 367; 369; 457.
94. Ear-pendant, pyriform outline.
Size: 3.1 × 2.3 cm. Iron. So III C 200.
FS. 2 V/Ca, H. 20.80 m. Early Kuṣāṇa. L.22
95. Foot-ring (or shackle?), flat section, with hinge.
Diam. 9.5 cm. H. 5.8 cm. Iron. So III C 202.
FS. 2 IV/Ca, H. 21.87–21.70 m. Kuṣāṇa. L.20
96. Bangle with one decorated end (intersected).
Diam. 4.7 cm. Copper or brass. So III C 533.
FS. 2 IV/Ca, H. 21.95 m. Kuṣāṇa. L.21
97. Fragment of a bangle or pin with thick curled end.
L. 4.5 cm. Copper. So III C 472.
FS. 2 IV/Ca, H. 21.81 m. Kuṣāṇa. L.21
98. Fragment of a bangle with flat-topped club-shaped end.
L. 4.4 cm. Copper. So III C 470.
FS. 2 IV/Cc, H. 21.30 m. Kuṣāṇa. L.20
99. Ring, flat section, open.
Diam. 2.0 cm. Copper. So III C 23.
FS. 2 IV/Cb, H. 22.90–22.40 m. Kuṣāṇa. L.17
100. Ring, plano-convex section, outside decorated with a patterned band coiled like a garland.
Diam. 2.1 cm. Copper. So I 232.
FS. 2 V/Cc, H. 21.10 m. Kuṣāṇa. L.20
101. Conical object: capstan shaped base, slender cone with spiral groove running up to the point. Ear-stud?
Diam. 2.1 cm. H. 5.2 cm. Brass. So III C 433.
FS. 2 III/Cc, H. 21.35 m. Kuṣāṇa. L.20
102. Ornamental object: toe-ring or mounting?
L. 7.4 cm. Copper or bronze. So III C 39.
FS. 2 IV/Cb, H. 23.43–23.13 m. Kuṣāṇa. L.17/16
- Period VI. Objects from Levels 15 to 12*
103. Arrow-head, leaf-shaped, tanged.
L. 10.0 cm. Iron. So III C 146.
FS. 2 III/Cb, H. 24.50–24.20 m. Gupta. L.15/14
Note: 2 more specimens of same type under So III C 226; 298.
104. Arrow-head, leaf-shaped, double tanged(?).
L. 9.1 cm. Iron. So III C 280.
FS. 2 IV/Ca, H. 25.30–24.90 m. Medieval. L.12
105. Rod with one pointed end.
L. 11.1 cm. Iron. So III C 268.
FS. 2 III/Ca, H. 25.10–24.70 m. Late Gupta. L.13
106. Tube, cylindrical.
L. 7.7 cm. Iron. So III C 216.
FS. 2 IV/Ca, H. 24.60–24.25 m. Gupta. L.15
107. Pincers with fragment of ring.
L. 16.0 cm. Iron. So III C 99.
FS. 2 III/Cb, H. 24.75–24.50 m. Gupta. L.14
108. Chisel, rectangular section.
Size: 8.3 × 1.9 cm. Iron. So III C 286.
FS. 2 V/Cb, H. 23.70–23.40 m. Gupta. L.15
109. Nail with broad square head (hat-shaped).
L. 9.9 cm. Diam. 3.7 cm. Iron. So III C 287.
FS. 2 IV/Ca, H. 24.80–24.55 m. Gupta. L.14/13
Note: 2 more specimens registered under So III C 203; 293.
110. Curved hook, flat.
Size: 3.5 × 1.6 cm. Iron. So III C 208.
FS. 2 IV/Ca, H. 24.10–23.80 m. Gupta. L.15
Note: One more specimen registered under So III C 299.
111. Rectangular hook, square section.
Size: 10.8 × 5.0 cm. Iron. So III C 177.
FS. 2 V/Cb, H. 24.20–23.90 m. Gupta. L.15/14
112. Double-hook (double talon), with socket.
Size: 9.4 × 3.7 cm. Iron. So III C 233.
FS. 2 V/Ca, H. 23.70–23.30 m. Gupta. L.15
113. Fragment of a pick-axe(?).
Size: 9.8 × 4.4 cm. Iron. So III C 185.
FS. 2 IV/Ca, H. 24.45–24.15 m. Gupta. L.15
114. Dumbbell-shaped object.
L. 7.5 cm. Iron. So III C 241.
FS. 2 IV/Ca, H. 23.95–23.65 m. Gupta. L.15
115. Part of chain.
L. 37.2 cm. Iron. So III C 284.
FS. 2 V/Cb, H. 23.80–23.55 m. Gupta. L.15
116. Small dish with bevelled rim, convex bottom.
Diam. 9.15 cm. H. 2.3 cm. So III C 18.
FS. 2 V/Ca, H. 24.60 m. Late Gupta. L.13
117. Concave neck and flat-topped everted rim of bottle.
Diam. 2.5 cm. Copper or brass. So III C 12.
FS. 2 IV/Ca, H. 24.90–24.60 m. Medieval. L.12
118. Circular knob with central cone, on which a square loop in the shape of an elephant is attached.
H. 3.5 cm. Bronze. So III C 40.
FS. 2 III/Cb, H. 24.25 m. Gupta. L.15
119. Wire, bent into an open circle (bangle?).
Diam. ca. 5.0 cm. Brass. So III C 16
FS. 2 IV/Ca, H. 25.20–24.70 m. Medieval. L.12
- Period VII. Objects from Levels 11 to 8*
120. Rod with loop.
L. 15.5 cm. Iron. So III C 106.
FS. 2 V/Cb, H. 25.60–25.10 m. Medieval. L.10
121. T-shaped nail.
L. 3.7 cm. W. 2.3 cm. Iron. So III C 246.
FS. 2 V/Cb, H. 25.65–25.40 m. Medieval. L.10

122. Fragment of a chain or snaffle bit.
Size: 5.0 × 4.8 cm. Iron. So III C 212.
FS. 2 V/Ca, H. 25.30–25.00 m. Medieval. L.11
Note: One more ring found together with no. 122, under So III C 214

123. Small plate, more or less octagonal, circular punch-marks, 7 encircling 1.
Size: 1.4 × 1.3 cm. Brass or copper. So III C 17.
FS. 2 IV/Cb, H. 25.95 m. Late Medieval. L.8/(7)

124. Ring, nearly square section.
Diam. 2.4–2.3 cm. Brass. So III C 8
FS. 2 V/Ca, H. 25.25 m. Late Medieval. L.9

Period VIII. Objects from Levels 7 to 1

125. Arrow-head, slender, square section, fragment of tang.
L. 7.8 cm. Iron. So III C 277.
FS. 2 IV/Cb, H. 26.23–25.98 m. Islam. L.7

126. Dagger.
L. 23.5 cm. Iron. So III C 220.
FS. 2 IV/Cb, H. 26.70–26.30 m. Islam. L.7

127. Cannon-ball.
Diam. 16.8 cm. Iron. So III C 569.
FS. Stuck in a wall of Level 5.
Note: Six more exactly same specimens under So III C 570.

128. Hairpin-shaped clamp or pincers.
Size: 12.4 × 4.3 cm. Iron. So III C 238.
FS. 2 V/Cb, H. 26.90 m. Jāt. L.4
Note: 2 more fragments under So III C 199; 304.

129. Ring, notched, gilt.
Diam. 3.8 cm. Copper(?), So III C 7.
FS. 2 V/Cb, H. 26.42 m. Jāt. L.6/5

130. Bangle, open.
Diam. 6.3 cm. Iron. So III C 243.
FS. 2 IV/Ca, H. 27.00–26.50 m. Jāt. L.6–4

131. Ring with vertically attached ornament, consisting of 2 framed hemispheres and 2 globules in between.
Size: 4.5 × 2.1 × 3.1 cm. Copper. So III C 363.
FS. 2 IV/Cb, H. 27.15 m. Jāt. c.L.6

132. Ring, slightly in-curved section.
Diam. 2.4–2.2 cm. Brass. So III C 3.
FS. 2 V/Ca, H. 26.30–25.80 m. Jāt. L.5/4

F. OBJECTS OF GOLD AND SILVER

1. Mutilated thin round gold foil with concentric circles.
Diam. 2.2 cm. Gold. So I 25
FS. 3 I/Ca, H. 17.00–16.65 m.
Late Maurya/Suṅga C.P., L.31/30
2. Small pendant or bead. Thin sheet metal, shaped like a broad pipal leaf.
Size: 1.8 × 1.35 × 0.01 cm. Gold. So I 196.
FS. 2 V/Ca, H. 20.60 m. Kṣatrapa. L.23
3. Ring, triangular section, open, tapering ends.
Diam. 1.8 cm. Gold. So I 48.
FS. Mud-rampart of north-eastern wall. Out of context.
4. Wire, bent in a circle, with hooked ends.
Diam. ca, 4.7 cm. Silver (?). So III C 32.
FS. 2 IV/Ca, H. 24.95 m. Early Medieval. L.12

G. JEWELRY MOULDS

1. Terracotta mould for a decorative pendant.
Size: 4.1 × 3.6 × 1.4 cm. Grey-brown. So I 330.
FS. 2 IV/Be, H. 16.60 m. Early Maurya. L.35/34
2. Fragment of a terracotta mould for a toe-ring(?).
Size: 3.4 × 3.1 × 1.2 cm. Grey-brown. So III A 984.
FS. 2 V/Cb, H. 22.50–22.20 m. Kuṣāṇa. L.18
3. Fragment of a stone mould for a necklace.
Size: 5.1 × 4.3 × 1.2 cm. Violet-brown. So I 9.
FS. 3 I/Ca, H. 24.50 m. Medieval. L.11



1



2



3



4



5



6



7

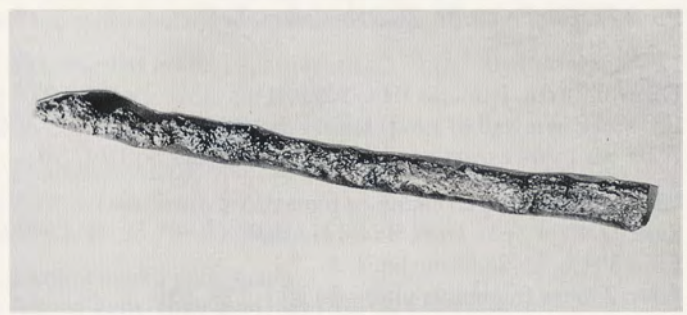

8



10

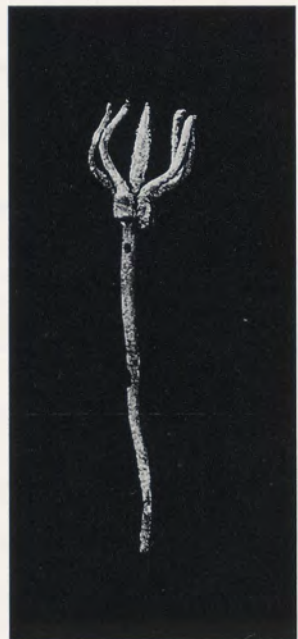

9

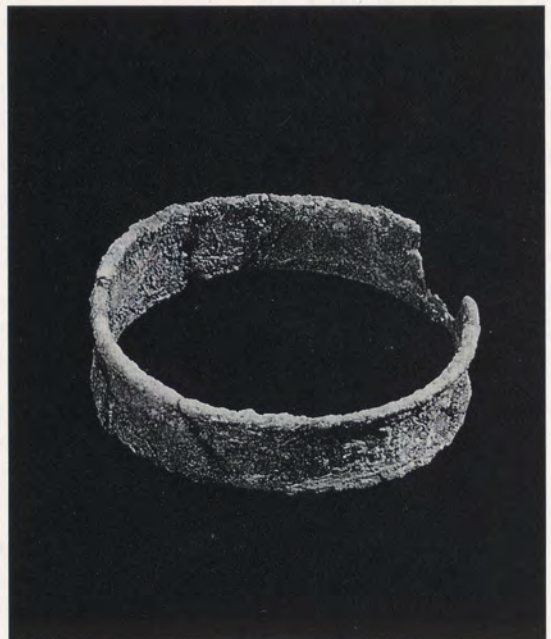

11

Metal Objects. Period I (1-4); Period II (5-11)



12



13



14



15



16



17



18

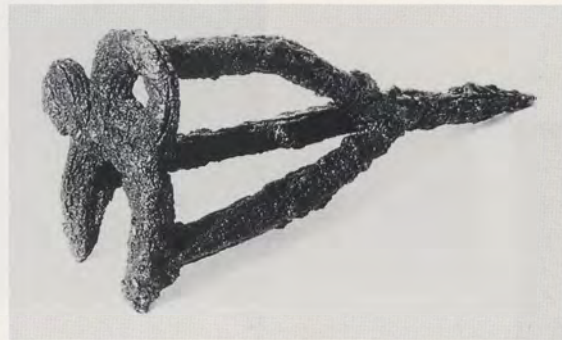

19



20



21



22



23



24

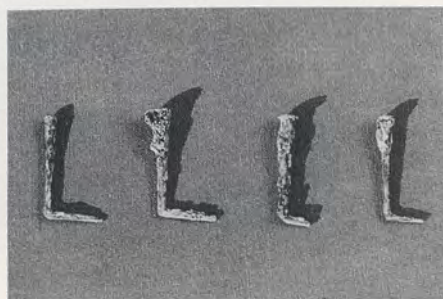

25



26



27



28



29



30



31

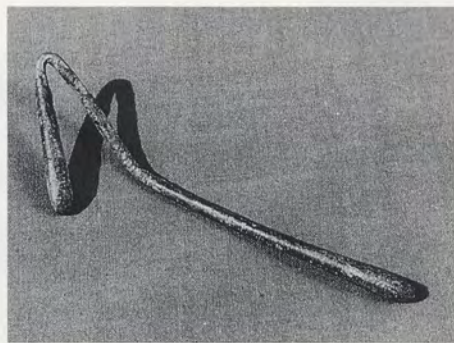

32



33



34



35



36

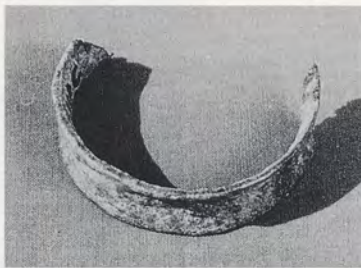

37

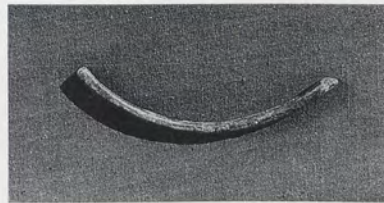

38

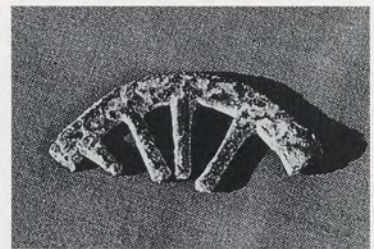

39



40



41



42



43



44



45



46



47



48



49



50



51



52



53



54



55



56



57



58



59

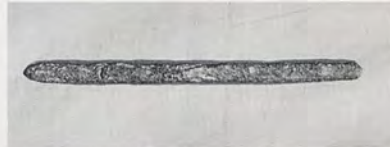

60



61

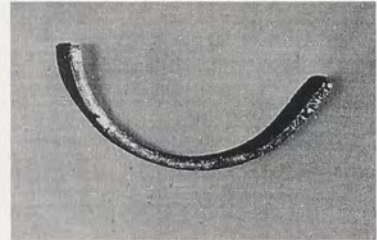

62

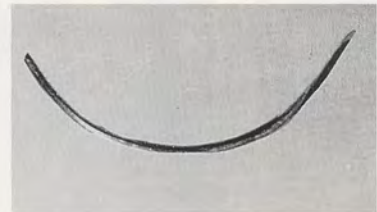

63



64



65



66



67



68



69



70



71



72



73



74



75



76



77



78



80



79



81



82



83



84



85



86



87



88



89



90

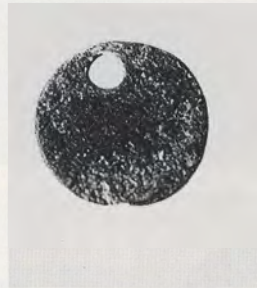

91

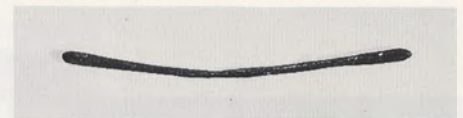

92



94



95

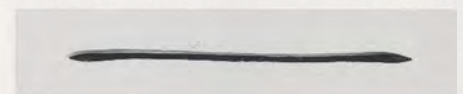

93



96



97



99



98



100



101



102



103



104



105



106



107



108



109



110



111



112



114



115



113



118



119



116



117



120



121



122

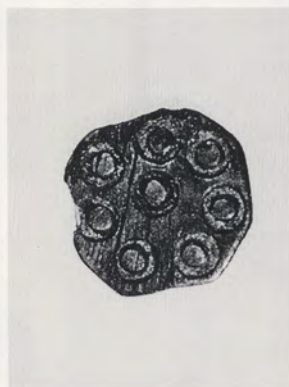

123



124



125

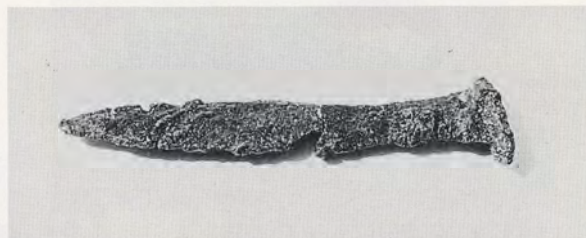

126



128



127



131



129



130



132



1



2



3



4

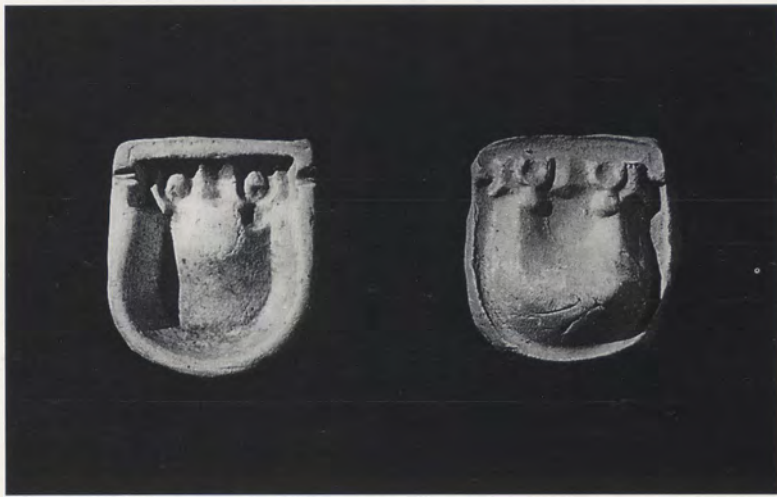

1



2



3

Objects of Gold and Silver (1-4) and Jewelry Moulds (1-3)

H. BEADS

During the excavation altogether 765 beads were unearthed, 595 of them clearly stratified. In Period I carnelian, agate and copper were the favoured materials. From Period II onwards other semi-precious stones like amethyst, jasper etc. came in use. In Period V faience and coloured glass put the other materials in the shade. That more than half of the beads belong to Kuşāṇa levels is mainly due to the fact that these levels have the greatest extension of undisturbed structural remains, so that more beads are found there in a clear context than in other levels, especially in the younger ones. Also the variety of materials and shapes is greater there than in any other level group. One could say, that with the beginning of the Kṣatrapa era, people felt the urge to embellish themselves with beads of semicircular stones, faience, different coloured glass, and other materials, more than in former periods. The different nature of material, the great variety of shapes and their appearance in the successive levels are best and fully documented in the distribution charts below. A selection of different types of beads is illustrated and described.

Materials	Periods						Total
	I	II	III	IV	V	VI/VIII	
Carnelian	3	14	6	8	37	13	81
Agate	3	8	2	1	21	3	38
White Quartz	—	1	2	3	6	6	18
Chalcedony	—	5	—	2	5	5	17
Jasper	—	4	2	2	2	1	11
Amethyst	—	1	1	1	6	2	11
Rock crystal	—	7	1	4	6	11	29
Incised	—	—	—	—	5	—	5
Etched	—	9	—	—	11	2	22
Lapis lazuli	—	—	—	—	3	1	4
Terracotta	—	10	10	4	9	5	39
Faience	—	—	2	5	62	4	73
Glass, green	—	1	6	2	45	11	65
blue green	—	3	2	1	25	6	37
blue	—	1	—	3	43	3	50
black	—	—	—	—	9	6	15
yellow	—	—	—	1	2	3	6
millefiori	—	—	—	—	5	1	6
gold foil	—	—	—	—	6	—	6
Copper	1	11	2	2	—	—	16
Shell	—	1	4	16	39	2	62
	7	68	40	55	340	85	595

Shapes	Periods					
	I	II	III	IV	V	VI/VIII
<i>Carnelian</i>						
Spherical	—	3	4	3	10	5
Spheroid, one concave end	—	—	—	—	1	—
Long barrel	2	—	—	—	3	1
Short barrel	—	—	1	1	2	—
Cylinder	—	—	—	—	1	—
Cylinder disc	—	—	—	—	1	—
Truncated bipyramid square	—	—	1	—	—	—
Long trunc. bipyram. hexagon	—	—	—	—	1	—
Polyhedron	—	1	—	3	7	—
Tabular	—	1	—	—	2	—
Leech	—	—	—	—	—	1
Doughnut	—	—	—	—	1	—
Dagger pendant	1	—	—	—	—	—

Shapes	Periods					
	I	II	III	IV	V	VI/VIII
<i>Agate</i>						
Spherical	1	3	—	—	1	1
Long barrel, circul.or ellipt.	—	—	—	—	6	2
Long barrel, plano-convex	—	—	—	—	1	—
Short barrel	1	—	—	—	1	—
Cylinder	—	—	1	—	2	—
Long cylinder	—	—	—	—	1	—
Oblique cylinder, convex ends	1	—	—	—	—	—
Disc	—	—	—	—	—	2
Short bicone, convex	—	—	—	—	1	—
Polyhedron pentagonal	—	—	1	—	—	—
Leech	—	2	—	—	—	—
Drop pendant	—	—	—	—	1	—
<i>White Quartz</i>						
Spherical	—	—	—	4	—	2
Barrel circular	—	—	1	—	3	1
Barrel hexagonal	—	—	—	—	1	2
Short cylinder	—	—	—	1	—	—
Prism flat hexagonal	—	1	—	—	—	—
Short prism square	—	—	—	1	—	—
Trunc. bipyramid pentagonal	—	1	—	—	—	—
Polyhedron	—	—	1	—	2	—
Pendant, long pyram. hexagonal	—	—	—	—	—	1
<i>Chalcedony</i>						
Spherical	—	2	—	1	—	—
Ellipsoid	—	—	—	—	—	1
Long barrel	—	3	—	—	—	1
Long barrel, rimmed	—	—	—	—	—	1
Prism hexagonal, rounded edges	—	—	—	—	—	1
Trunc. bipyramid, tetragonal	—	—	—	—	1	1
Rectangular, flat, rounded edges	—	—	—	—	—	1
Toggle	—	—	—	—	1	—
<i>Jasper</i>						
Polyhedron	—	2	2	2	3	1
Tiny irregular circular	—	1	—	—	—	—
<i>Amethyst</i>						
Spheroid	—	1	—	—	—	1
Ellipsoid	—	1	—	—	—	—
Lenticular	—	—	—	—	1	—
Barrel pentagonal	—	—	—	—	2	—
Barrel hexagonal	—	—	1	1	1	1
Pendant hexagonal drop	—	—	—	—	1	—
Pendant trunc. bipyram.tetragonal	—	—	—	—	1	—
<i>Rock Crystal</i>						
Spherical	—	—	—	—	2	2
Ellipsoid	—	—	—	1	—	—
Lenticular	—	—	—	—	1	—
Barrel hexagonal	—	—	1	2	—	2
Truncated bicone disc	—	1	—	—	—	—
Bipyramid hexagonal	—	1	—	—	1	4
Trunc. bipyramid square	—	—	—	—	1	—
Polyhedron hexagonal	—	2	—	—	2	3
Rectangular flat	—	1	—	—	—	—
Conv. concave bulged, tilted rims	—	1	—	—	—	—
Pendant, polyhedral	—	1	—	—	—	—
Fish-shaped	—	—	—	1	—	—

Shapes	Periods					
	I	II	III	IV	V	VI/VIII
<i>Incised</i>						
Long barrel coll.milky quartz	-	-	-	-	1	-
Long barrel one coll.milky quartz	-	-	-	-	3	-
Long barrel one coll.carnelian	-	-	-	-	1	-
<i>Etched</i>						
Spherical,black agate,white pattern	-	2	-	-	-	-
Spherical,carnel.,grey pattern	-	-	-	-	1	-
Spherical,carn.,white fringed,dots	-	-	-	-	1	1
Spherical,black chalc.,white patt.	-	2	-	-	-	-
Spheroid,carnel.,white circles	-	-	-	-	1	-
Barrel,white stone,black pattern	-	-	-	-	1	-
Long barrel,black ag.,white patt.	-	3	-	-	5	-
Long barrel,carnel.,white pattern	-	3	-	-	-	-
Long barrel,carn.,black "suns"	-	-	-	-	1	-
Long barrel,black chalc.,col.patt.	-	3	-	-	-	-
Trunc.lozenge tab.,carn.,white p.	-	-	-	-	-	1
<i>Lapis lazuli</i>						
Spherical	-	-	-	-	-	1
Long barrel octagonal	-	-	-	-	1	-
Prism tetragonal	-	-	-	-	1	-
Trunc. pyramid tetragonal	-	-	-	-	1	-
<i>Terracotta</i>						
Spheroid/spherical	-	6	8	-	-	-
Ellipsoid/ovoid	-	-	-	-	1	1
Cylinder	-	-	-	1	1	-
Curved cylinder granulated	-	1	-	-	-	-
Long cylinder intersected	-	-	-	1	-	-
Barrel elliptical	-	-	1	-	-	-
Big short barrel	-	-	1	-	-	-
Bicone	-	-	1	-	1	1
Prism rectangular	-	-	-	-	1	-
Lenticular nearly circular	-	-	-	-	1	-
Irregular oblate,protruding ends	-	1	-	-	-	-
Pyriform	-	-	-	1	-	-
Toggle	-	-	-	-	1	-
Pendant (frmt), lateral bore	-	-	-	1	-	-
Pendant (frmt)	-	-	-	-	1	-
Pendant, spade-shaped, moulded	-	1	-	-	-	-
<i>Faience</i>						
Spheroid/Spherical	-	-	1	1	-	1
Ellipsoid	-	-	-	-	1	-
Hemi-ellipsoid	-	-	-	1	-	-
Long barrel circular	-	-	-	-	4	-
Long barrel tetragonal	-	-	-	-	1	-
Long barrel pentagonal	-	-	-	-	1	-
Long barrel hexagonal	-	-	-	-	2	-
Short barrel circular	-	-	-	-	3	1
Short barrel angular	-	-	-	-	8	-
Short cylinder	-	-	-	-	1	-
Short column rectangular	-	-	-	-	1	-
Column square cornerless	-	-	-	-	5	-
Short column cornerless	-	-	-	3	7	-
Oblate oval	-	-	-	-	1	-
Toggle	-	-	-	-	3	-
Spherical gadrooned	-	-	-	-	3	1
Oblate pentagonal gadrooned	-	-	-	-	1	-

Shapes	Periods					
	I	II	III	IV	V	VI/VIII
Cogwheel	-	-	-	-	7	-
Short barrel spiked	-	-	-	-	2	-
Jar-shaped gadrooned	-	-	-	-	1	-
Pendant, cowry-shaped	-	-	1	-	3	-
Pendant, frog-shaped	-	-	-	-	1	-
Blossom-shaped	-	-	-	-	-	1
Animal's head	-	-	-	-	1	-
Figural (frmt)	-	-	-	-	1	-
<i>Green glass</i>						
Spherical/Spheroid	-	-	1	-	3	-
Ellipsoid, chamfered rim, striated	-	-	-	-	1	-
Cylindrical	-	-	1	-	2	1
Oblique cylinder	-	1	-	-	1	1
Long barrel circular or ellipt.	-	-	-	-	12	-
Short barrel rectangular	-	-	-	-	1	1
Barrel, flattened hexagonal	-	-	-	-	1	-
Barrel, rudimentary rims	-	-	-	-	3	1
Short barrel, flat, rimmed	-	-	-	-	1	-
Circular flat, rimmed	-	-	-	-	3	-
Irregular circular	-	-	-	-	3	2
Prism hexagonal	-	-	-	-	1	2
Prism w. pyram. ends, hexagonal	-	-	-	-	-	1
Bicone	-	-	-	-	4	-
Cone	-	-	-	-	-	1
Long pyramid rhombic	-	-	-	-	1	-
Truncated bipyramid rectangular	-	-	-	-	-	1
Truncated bipyramid square	-	-	-	-	1	-
Lenticular	-	-	-	-	2	1
Annular, tiny	-	-	-	1	4	-
Pendant, dagger or spindle	-	-	3	-	1	-
<i>Blue-green glass</i>						
Long cylinder	-	-	-	-	2	1
Small long cylinder	-	-	-	-	3	-
Long cylinder, rimmed	-	-	-	-	1	-
Short cylinder	-	-	-	-	2	-
Oblique short cylinder	-	1	-	-	5	2
Long barrel hexagonal	-	1	-	-	1	-
Short barrel circular	-	-	1	-	-	-
Barrel disc circular	-	-	-	-	-	1
Short barrel, one rim	-	-	-	-	1	-
Half barrel circular	-	-	-	-	1	-
Prism hexagonal	-	1	-	-	-	-
Trunc. pyramid tetragon., convex	-	-	-	-	-	1
Tiny ellipsoid	-	-	-	-	1	-
Biconvex circular	-	-	-	-	2	1
Biconvex disc circular	-	-	-	-	3	-
Lenticular circular	-	-	-	-	2	-
Irregular plano-convex	-	-	-	1	-	-
Toggle	-	-	1	-	-	-
<i>Blue glass</i>						
Spherical	-	-	-	-	6	-
Long cylinder	-	-	-	-	2	-
Cylinder, convex ends	-	-	-	-	7	1
Short cylinder	-	-	-	1	4	-
Oblique cylinder	-	-	-	-	1	-
Long barrel circular or ellipt.	-	-	-	-	1	-

Shapes	Periods					
	I	II	III	IV	V	VI/VIII
Short barrel circular	–	–	–	–	8	–
Short barrel rectangular	–	–	–	–	–	1
Barrel hexagonal	–	–	–	–	1	1
Barrel, wide bore, circular	–	–	–	–	2	–
Cube	–	–	–	–	2	–
Prism tetragonal	–	–	–	–	1	–
Prism pentag.,convex ends,curled	–	–	–	–	1	–
Prism hexagonal	–	–	–	1	–	–
Truncated cone	–	–	–	–	1	–
Pyramid, square	–	–	–	–	1	–
Ellipsoid	–	–	–	–	1	–
Circular, flat, rimmed	–	–	–	1	–	–
Irregular circular	–	–	–	–	4	–
<i>Black glass</i>						
Spherical	–	–	–	–	2	1
Spheroid, white stripes	–	–	–	–	1	2
Long cylinder, rimmed	–	–	–	–	1	–
Small oblique cylinder	–	–	–	–	1	–
Short barrel circular	–	–	–	–	1	1
Small barrel irregular	–	–	–	–	1	–
Barrel,one rudiment. rim,curled	–	–	–	–	1	1
Waisted–jar–shaped,rudiment.rim	–	–	–	–	–	1
Long segmented tube	–	–	–	–	1	–
<i>Yellow glass</i>						
Long segmented tube, circular	–	–	–	–	1	–
Small truncated bicone	–	–	–	–	–	1
Small irregular	–	–	–	–	–	1
Irregular	–	–	–	–	–	1
Small annular	–	–	–	1	1	–
<i>Millefiori</i>						
Barrel collared flat	–	–	–	–	3	1
Circular flat	–	–	–	–	2	–
<i>Gold–foil glass</i>						
Spherical, one rudiment. rim	–	–	–	–	2	–
Oblate, short rims, striated	–	–	–	–	1	–
Short barrel, rimmed, gilt core	–	–	–	–	3	–
<i>Copper</i>						
Spheroid	1	8	1	1	–	–
Short cylinder	–	4	–	–	–	–
Pendant, needle–shaped	–	–	1	–	–	–
<i>Shell</i>						
Spherical	–	–	–	1	4	–
Spheroid, wedge–shaped	–	–	–	–	1	–
Long barrel circ./ellipt./square	–	1	–	1	5	2
Barrel circular	–	–	1	1	–	–
Barrel,wedge–shaped,circ./triang.	–	–	–	1	13	–
Short cylinder	–	–	–	–	1	–
Cylinder, wedge–shaped	–	–	–	–	1	–
Oblique cylinder	–	–	–	–	1	–
Barrel disc	–	–	–	–	2	–
Cylinder disc	–	–	–	–	2	2
Oblique cylinder disc	–	–	–	–	2	–
Oblate disc	–	–	–	–	1	–

Shapes	Periods					
	I	II	III	IV	V	VI/VIII
Trunc.pyramid disc square	–	–	–	–	1	–
Lenticular disc heptagonal	–	–	–	–	1	–
Flat oval collared	–	–	–	10	–	–
Flat lozenge	–	–	–	2	–	–
Flat square	–	–	–	–	2	–
Big irregular	–	–	–	–	1	–
Irregular trapezoid	–	–	–	1	1	–
Irregular wedge–shaped	–	–	–	–	1	–
Irregular globular	–	–	–	–	1	–
Toggle	–	–	–	–	2	–
Pendant	–	–	–	–	1	–
Dagger pendant	–	–	1	–	–	–
Animal skull pendant	–	–	–	–	1	–
Snail shell	–	–	–	–	1	–

Selected Beads

1. Agate, short cylinder elliptical, orange and white banded. Diam. 0.7 cm. L. 0.5 cm. So III E 414. FS. 3 I/Ca, H. 15.50–15.00 m. PGW-L.37
2. Agate, leech in shape of a truncated crescent, flat, with horizontal brownish and bluish striations. L. 1.9 cm. H. 0.8 cm So I 33. FS. 3 I/Ca, H. 15.50 m. Early Maurya. L.36
3. Copper, oblate spheroid, corroded. Diam. 1.1 cm. L. 0.75 cm. So III E 748. FS. 2 IV/Cc, H. 14.65–14.50 m. Early Maurya. L.35
4. Glass, long barrel hexagonal, transparent light blue-green. Diam. 1.0 cm. L. 1.4 cm. So III E 658. FS. 2 IV/Be, H. 16.80–16.65 m. Early Maurya. L.35
5. Carnelian, long barrel nearly circular, dark orange. Diam. 0.3 cm. L. 1.5 cm. So I 43. FS. Trench 2, H. 16.30 m. Maurya. L.34
6. Carnelian, globular, orange with milky stripes. Diam. 1.2 cm. L. 1.1 cm. So III E 656. FS. 2 IV/Be, H. 17.55–17.30 m. Maurya. L.33
7. Carnelian, faceted tetragonal (“cornerless cube”), orange. Diam. 0.8 cm. L. 0.7 cm. So III E 750. FS. 2 IV/Cc H. 15.60–15.45 m. Maurya. L.33
8. Carnelian, long barrel circular, light orange, white etched. Diam. 0.9 cm. L. 1.79 cm. So III E 745. FS. 2 IV/Cc, H. 16.15–16.00 m. Late Maurya. L.32/31
9. Carnelian, standard faceted, orange. Diam. 0.9 cm. So III E 516. FS. 3 I/Ca, H. 17.00–16.90 m. Śuṅga C.P., L.30
10. Black chalcedony, spherical, white etched. Diam. 0.85 cm So III E 716. FS. 2 IV/Cc, H. 16.60–16.45 m. Śuṅga C.P., L.30
11. Rock crystal, short truncated bipyramid hexagonal, transparent. Diam. 0.7 cm. So III E 526. FS. 3 I/Ca, H. 16.85–16.75 m. Śuṅga C.P., L.31
12. Glass, short barrel, opaque blue. Diam. 0.6 cm. L. 0.5 cm. So III E 349. FS. 3 I/Ca, H. 17.47–17.17 m. Śuṅga C.P., L.30/29

13. Shell, long barrel circular, white.
Diam. 0.8 cm. L. 1.3 cm. So III E 525.
FS. 3 I/Ca, H. 16.60 m. Śuṅga C.P., L.31
14. Amethyst, long barrel oval, violet.
Diam. 0.9 cm. L. 1.3 cm. So I 31.
FS. 3 I/Ca, H. 17.50 m. Early Mitra. L.28
15. Glass, small spindle pendant, green.
Diam. 0.47 cm. H. 1.0 cm. So III E 709.
FS. 2 V/Cb, H. 18.18–17.90 m. Mitra. L.27
16. White Quartz, spherical, milky.
Diam. 0.7 cm. So III E 543.
FS. 2 V/Cb, H. 19.55–19.40 m. Kṣatrapa. L.24
17. Carnelian, short barrel circular, orange.
Diam. 0.55 cm. L. 0.45 cm. So III E 615.
FS. 2 IV/Ca, H. 20.92–20.78 m. Kṣatrapa. L.23
18. Rock crystal, prism plano-convex hexagonal.
Diam. 1.2 cm. L. 1.75 cm. So III E 616.
FS. 2 V/Cb, H. 19.50 m. Kṣatrapa. L.24/23
19. Shell, flat oval with protruding ends, light brown.
L. 1.7 cm. So III E 503.
FS. 2 V/Ca, H. 20.00–19.75 m. Kṣatrapa. L.23
20. Terracotta, long segmented cylinder (10 grooves) elliptical, grey-brown.
Diam. 0.5–0.7 cm. L. 2.7 cm. So III E 572.
FS. 2 V/Ca, H. 20.17–19.78 m. Kṣatrapa. L.23
21. Agate, long barrel oval, grey-brown striated.
Diam. 0.67 cm. L. 1.65 cm. So III E 187.
FS. 2 V/Cb, H. 22.00–21.70 m. Kuṣāṇa. L.20/19
22. Agate, long barrel circular, transparent with milky layers.
Diam. 0.75 cm. L. 2.0 cm. So III E 648.
FS. 2 IV/Cc, H. 20.85–20.65 m. Ditch from L.19. Kuṣāṇa.
23. Agate, long barrel elliptical, black, white and blue.
L. 2.24 cm. W. 1.35 cm. So III E 379.
FS. 2 V/Cb, H. 21.08–20.80 m. Kuṣāṇa. L.21
24. Carnelian, spherical, dark orange.
Diam. 1.0 cm. So III E 627.
FS. 2 IV/Ca, H. 21.48–21.33 m. Kuṣāṇa. L.21
25. Amethyst, long barrel pentagonal with excentric channel, violet.
Diam. 0.8 cm. L. 1.15 cm. So III E 359.
FS. 2 V/Ca, H. 21.10–20.85 m. Kuṣāṇa. L.21
26. White Quartz, long barrel elliptical, rudimentary rims, incised cross-hatch pattern, blue-green residues, milky.
Diam. 1.0 cm. L. 1.5 cm. So III E 623.
FS. 2 IV/Cb, H. 21.42–21.25 m. Kuṣāṇa. L.21
27. Black agate, long barrel circular, white etched ornament.
Diam. 0.8 cm. L. 1.9 cm. So III E 341.
FS. 2 IV/Cc, H. 20.30–20.10 m. Kuṣāṇa. L.22
28. Carnelian, spherical, white etched pattern on orange.
Diam. 0.7 cm. So III E 495.
FS. 3 I/Cb, H. 21.10–20.70 m. Kuṣāṇa. L.21
29. Lapis lazuli, truncated pyramid square.
Diam. 1.2 cm. L. 1.3 cm. So III E 562.
FS. 2 III/Cb, H. 21.70–21.50 m. Kuṣāṇa. L.21
30. Shell, short cylinder, corroded, grey-brown.
Diam. 0.92 cm. L. 0.74 cm. So III E 467.
FS. Diam. 0.92 cm. L. 0.74 cm. So III E 467.
FS. 2 V/Cb, H. 20.85–20.55 m. Kuṣāṇa. L.21
31. Shell, rectangular flat, rounded, dark grey.
L. 1.1 cm. W. 0.9 cm. So III E 212.
FS. 2 IV/Cb, H. 23.63–23.38 m. Late Kuṣāṇa. L.16
32. Shell, toggle, white.
L. 1.1 cm. Diam. 1.2–0.35 cm. So III E 459.
FS. 2 V/Cc, H. 22.20–21.90 m. Kuṣāṇa. L.18/17
33. Glass, circular flat, thick rims, green.
L. 1.8 cm. W. 1.3 cm. So III E 307.
FS. 2 IV/Cc, H. 21.32–20.95 m. Kuṣāṇa. L.21
34. Glass, circular lenticular, blue-green.
L. 0.95 cm. So III E 327.
FS. 2 IV/Cb, H. 21.65–21.50 m. Kuṣāṇa. L.21
35. Glass, barrel circular, one rudimentary rim, curled black with white stripes.
Diam. 1.05 cm. So III E 305.
FS. 2 IV/Cb, H. 21.76–21.51 m. Kuṣāṇa. L.21/20
36. Glass, globular, blue.
Diam. 0.9 cm. So III E 326.
FS. 2 IV/Cb, H. 21.55–21.30 m. Kuṣāṇa. L.21
37. Glass, circular flat, blue-green with red-white-black wavy pattern (Millefiori glass).
L. 0.9 cm. D. 0.25 cm. So III E 281.
FS. 2 V/Ca, H. 22.52–22.22 m. Kuṣāṇa. L.18
38. Glass, oblate, low rims, gilt surface, yellowish, striated.
Diam. 0.7 cm L. 0.6 cm. So III E 338.
FS. 2 V/Cb, H. 22.05–21.45 m. Kuṣāṇa. L.19/18.
39. Faience, jar-shaped, gadrooned, whitish turquoise.
Diam. 1.0 cm. L. 0.77 cm. So III E 357.
FS. 2 IV/Cc, H. 19.90–19.60 m. Early Kuṣāṇa. L.23/22
40. Faience, awl-shaped toggle, turquoise.
L. 2.04 cm. W. 0.5 cm. D. 0.3 cm. So III E 528.
FS. 2 V/Cb, H. 20.95 m. Early Kuṣāṇa. L.22
41. Faience, animal's head, light blue-green.
L. 0.95 cm. W. 1.3 cm. D. 0.8 cm. So III E 621.
FS. 2 IV/Ca, H. 21.55–21.40 m. Kuṣāṇa. L.21

I. SEALS AND SEAL-IMPRESSIONS

Periods III to VI yielded six seals and twenty-three seal-impressions, all of terracotta. Of the seals four are inscribed, and two show symbols and running animals. Among the seal-impressions seventeen are inscribed, five show symbols and one a human figure. The three oldest seals (nos. 1 to 3) are unusually inscribed in the positive, i.e. the impression appears in the negative. One of them has the akṣaras arranged in some sort of circle (no. 1), a later seal mixes the letters as if intending to produce a puzzle (no. 12). With the exception of the biscriptural impression no. 16 all inscribed seals are in Brāhmī.

1. Terracotta seal-impression, plano-convex, circular, elevated edge. Six letters in the negative, to be read anti-clockwise. The text reads, beginning with negatively seen initial *a* on the lower edge: *ana*, to the right: *ra*, after a quarter turn to left: *bbū*, return to first position: *tiṃ*. Altogether *anarabbūtiṃ*. It is the only seal or seal-impression from Sonkh not ending in the genitive.

Diam. 2.5 cm. Colour: brown. No. So I 276.
FS. 3 I 4.3/Ca 6.8, H. 16.50 m. Position of a pit in L.32, starting presumably in an early Mitra level.

2. Rectangular terracotta seal having a short knob as handle. Upper (outer) part of the nearly square block is slightly curved and decorated with incised lines. Two more such lines are visible at the foot of the knob. The inscribed level is without border and partly chipped off. The seal is inscribed in the positive and reads: Top: Nandyāvarta symbol

L.1: *sa[r]va..*

L.2: *sa*

It is the seal “of Sarva..”.

2.2 × 2.0 × 1.9 cm. Colour: grey by fire. No. So I 317.

FS. 2 IV 7.2/Be 15.7, H. 19.22 m. Mitra. L.27

3. Terracotta seal in shape of a small bell with short handle. Strongly chaff-tempered. Inscribed level circular and without border but slightly damaged on the edge. Similar to no. 1 the akṣaras are to be read “around the corner”. The main line reads [*pī*] *dadaḥka*. Now turn it upside down and read *kaṣa*. The seal “of Pīdadakhaka” (Piṇḍadakṣaka).

Diam. 3.7 cm. H. 3.3 cm. Colour: grey-brown. No. So I 228.

FS. 3 I 1.9/Ca 14.6, H. 18.66 m. Mitra. L.26

4. Terracotta seal-impression, plano-convex, circular, rounded edge partly chipped off. Two lines of stylized Brāhmī reading:

L.1: *anūbhūti*

L.2: *sa*

It is the seal “of Anubhūti”.

Diam. 1.6 cm. Colour: red-brown. No. So I 345.

FS. 2 IV 16.35/Cc 1.3, H. 16.78 m. Found in a ditch which reaches down to L.30 but starts in one of the later Mitra levels.

There are two more seal-impressions giving the same name written in comparable script. They have been found in early Kuṣāṇa levels, one of them presumably impressed by a seal preserved in the family for long (no. 5), but the other (no. 6) seems rather a copy of a later and faulty seal, although the script imitates the older ductus.

5. Terracotta seal-impression, plano-convex, circular, with remains of lined border. Ductus as in no. 4:

L.1: *anubhūti*

L.2: *sa*

The seal “of Anubhūti”. See remarks under no. 4.

Diam. 1.6 cm. Colour: light brown. No. So I 287.

FS. 2 III 15.5/Cb 9.1, H. 22.10 m. In a ditch beginning in the Jāt period, the seal originating presumably from L.21 or earlier.

6. Terracotta seal-impression, plano-convex, circular, with elevated rounded rim. Script imitates the ductus of nos. 4 and 5. The text reads: [*a*] *nubbutisa* with the *sa* placed above the *bhu* (short vowel). The writing is faulty because the *nu* and the *ti* are negative, and the *bhu* and *sa* positive.

Diam. 1.8 cm. Colour: dull red. No. So I 335.

FS. 2 IV 14.2/Ca 19.3, H. 21.50 m. Kuṣāṇa. L.21

7. Terracotta seal-impression, plano-convex, circular, uneven rim. Three impressed symbols from left to right: 1) Svastika (right turn), 2) Hala (plough, long shaft), 3. Taurine symbol (standing on head).

Diam. 2.2 cm. Colour: brown with sand. No. So I 295.

FS. 2 V 6.5/Ca 2.9, H. 19.20 m. Mitra. L.26/25

8. Terracotta seal with conical perforated knob. Carelessly incised symbols: Svastika, taurine symbol, oblique stroke.

Diam. 2.9/1.8 cm. H. 2.6 cm. Light brown. No. So I 229.

FS. 3 I 1.7/Ca 15.3, H. 18.66 m. Mitra. L.26

9. Terracotta seal-impression, plano-convex, circular. The impression is three-lined:

L.1: Svastika

L.2: *namdikarasa*

L.3: Taurine symbol, turned flat.

The seal “of Nandikara”.

Diam. 2.3 cm. Colour: dull red. No. So I 97.

FS. Trench 4. Filling. On the analogy of the ductus to be placed in L.26/25

10. Terracotta seal-impression, plano-convex, circular, slightly shallow. Three convex symbols from left to right: 1) Taurine symbol (i.e. crescent upon dot), 2) Svastika (left turn), 3) Taurine symbol standing on head. Below these symbols a sign looking like a winged flying bird.

Diam. 2.5 cm. Colour: brown. No. So I 217.

FS. 3 I 2.7/Ca 10.6, H. 19.30 m. Mitra. L.25

11. Terracotta seal, circular, with perforated flat knob. The surface shows a plain centre surrounded by six animals running one behind the other. These are deer, haṃsa, hare, vulture, antelope, and makara (?). This frieze is bordered by a double string each on the inner and the outer side.

Ø 2.5 cm. D.1.5 cm. Brown, partly blackened by fire.

No. So I 84. FS. Trench 4, H. 20.40 m. Mitra. L.25

12. Terracotta seal-impression, plano-convex, circular. On top a square of four small circles balanced on one corner. Below it one line of script reading *brah[mami]tasa*, i.e. the seal “of Brahmamitra”. Script and ornament are bordered by a circular double line decorated on its outer side with triangles.

Diam. 2.45 cm. Colour: grey-black. No. So I 72.

FS. Surface find. On the ground of palaeography to be dated in the Mitra period. It may be worth to consider the possibility that the “ornament” above the line of script depicts part of the coin symbol of king Brahmamitra.

13. Terracotta seal-impression, plano-convex, nearly circular. Convex symbol of three-armed windwheel.

Diam. 1.9 cm. Colour: grey. No. So III A 1930.

FS. 2 V 10.75/Ca 8.25, H. 20.25 m. Kṣatrapa. L.23

14. Terracotta seal with perforated conical knob. Circular. Five negative akṣaras are arbitrarily scattered. Put together in the right way it reads

kāmadatasa, i.e. the seal “of Kāmadatta”.

Diam. 2.7 cm. H. 2.9 cm. Colour: brown. No. So I 254.

FS. 2 V 14.5/Cb 0.6, H. 20.25 m. Kṣatrapa. L.23

15. Mutilated terracotta seal-impression, originally circular. Three lines of symbols and script.
L.1: Nandyāvarta or taurine symbol, nearly illegible.
L.2: *kāṇa[sa]*
L.3: Svastika (right turned).
The seal “of Kāṇa”.
Diam. 2.1 cm. Blackened by fire. No. So I 258.
FS. 2 V 2.7/Ca 18.3, H. 20.00m. Kṣatrapa. L.23
16. Seal-impression in unbaked clay, nearly circular. Two lines of script. The upper one written in Kharoṣṭhī, the lower one in Brāhmī. Both reading the same name *anaṅgabalasa*, i.e. the seal “of Anaṅgabala”. A rare biscriptual document.
Script level 1.8 × 1.6 cm. Grey. No. So I 265.
FS.2 V 15.8–17.8/Cc 0.5–5.7, H. 20.00–19.80m.
Kṣatrapa. L.23
17. Lenticular seal-impression in a lump of unbaked clay. Five syllables, reading *mahāmātra[sa]*, the seal “of the Mahāmātra”.
Script level 2.0 × 0.7 cm. No. So I 256.
FS. 2 V 2.8/Ca 17.5, H. 20.00m. Kṣatrapa. L.23
18. Terracotta seal-impression, plano-convex, circular. A sharp edge on the right shows that the impression was rectangular. One line of script, reading *rajatikasa*, i.e. the seal “of Rajatika”. Below this line stands a long-stretched humped bull to right.
Diam. 4.2 cm. Colour: grey. No. So I 346.
FS. 2 III 13.0/Cc 7.9, H. 20.00m.
Late Kṣatrapa. L.23/22
19. Mutilated terracotta seal-impression, plano-convex, circular. Seal three-lined:
L.1: Svastika
L.2: *g(o)pālasa*
L.3: Stylized humped bull to left.
The seal “of Gopāla”.
Diam. 4.0 cm. Colour: brown.
No. So I 283. FS. Surface find. On analogy of no. 18 datable to late Kṣatrapa.
20. Terracotta seal-impression, plano-convex, circular. One line of script, reading *sujātasa*, the seal “of Sujāta”.
Diam. 2.2 cm. Colour: dull red.
No. So I 125. FS. 2 IV 0.6/Ca 1.0, H. 24.95m. Out of context.
Ductus of script comparable with no. 18.
21. Mutilated terracotta seal-impression, plano-convex, circular, elevated rim. One line of script, reading *rumgipā..*
Diam. 1.9 cm. Blackened by fire. No. So I 341.
FS. 2 IV 10.2/Cc 2.3, H. 19.70m. Kṣatrapa. L.23/22
22. Terracotta seal with square stamp and perforated cylindrical knob. On top an incised rosette. The seal is three-lined:
L.1: Nandyāvarta symbol
L.2: *amoghanāṇḍisa* (negative)
L.3: Svastika and Śrīvatsa symbols
The seal “of Amoghanandi”.
H. 2.6 cm. Script level 2.5 × 2.6 cm. Brown. No. So I 273.
FS. 2 V 18.2/Cc 4.0, H. 20.00m. Early Kuṣāṇa. L.22
23. Seal-impression on unbaked clay, oval. Mutilated impression of a man standing or walking right with arms stretched to the sides, holding an indistinct object with the left hand. On the right leg appears a sword (?), hanging down from the garment.
Size: 3.0 × 2.3 cm. Colour: grey. No. So I 316.
FS. 2 V 0.5–4.0/Cb 12.0–14.0, H. 20.95–20.75 m.
Kuṣāṇa. L.21
24. Terracotta seal-impression, plano-convex, circular. Slightly shallow level. A circle of convex dots surrounds a trident-cum-battle-axe symbol and a small bisected circle to the right of it. The buckle of the reverse shows irregular star-like incisions.
Diam. 3.5 cm. Colour: light brown. No. So I 240.
FS. 2 V 8.1/Cc 0.25, H. 22.15m. Kuṣāṇa. L.17
25. Terracotta seal-impression, plano-convex, circular. Deeply impressed field with Nandyāvarta symbol above one line of Brāhmī reading *kāmbelasa*, The seal “of Kāmbela”.
Diam. 0.8 cm. Colour: grey. No. So I 207.
FS. 2 V 19.2/Ca 19.8, H. 22.45m. Kuṣāṇa. L.18
26. Mutilated terracotta seal-impression, plano-convex, originally circular. Remains of four akṣaras reading [*p*] *utraka[sa]*, seal “of Putraka”.
Diam. 2.2 cm. Colour: grey-brown. No. So III A 1817.
FS. 2 III 11.0/Cb 16.5, H. 22.50m. Kuṣāṇa. L.18/17
27. Terracotta seal-impression, plano-convex, circular with depiction of a snake.
Diam. 2.4 cm. Colour: light brown. No. So III A 995.
FS.2 IV 1.5/Be 13.5, H. 23.00m. Late Kuṣāṇa. L.17/16
28. Lenticular seal-impression in a lump of unbaked clay. One line of Gupta-Brāhmī reading *sūyag[utasa]*, the seal “of Sūryagupta”.
L. 4.2 cm. Colour: grey. No. So I 138.
FS.2 IV 2.2/Ca 18.1, H. 24.10m. Gupta. L.14
29. Seal-impression in oval lump of unbaked clay. In the upper half a seated two-armed Ganesha with trunk to left. Below, separated by a convex line, two lines of box-headed Brāhmī reading
L.1: *śrī[ratna]kāsanādbi*
L.2: *karaṇasya*
The seal “of (the office of) Śrī Ratnakāsana”
H. 5.3 cm. Colour: grey. No. So I 234.
FS. 2 IV 19.5–2 V 0.5/Cb 10.5–19.5, H. 22.94–22.64m. The find spot is late Kuṣāṇa which seems a bit too early for this seal.

J. OTHER INSCRIBED OBJECTS

Besides the terracotta seals and seal-impressions with names or titles seven more inscribed objects have been found, five of them fragments of stone plates or sculptures of Kuṣāṇa origin. The two earliest pieces are a fragment of a stone casket from level 23, and an early Kuṣāṇa terracotta dabber.

1. Fragment of a small slate casket with five akṣaras around the body reading *goya[ṭhaśa]*.

Ø 5.3 cm. H. 2.5 cm. Colour: brown-grey. No. So I 307.
FS. 2 V 2.5/Cb 13.4, H. 19.95 m. Late Kṣatrapa. L.23

2. Terracotta dabber with three akṣaras around conical body, reading *bu[kā]sa*.

Ø 9.3 cm. H. 7.7 cm. Colour: brown. No. So III A 3199.
FS. 2 IV/Ca 2.0, H. 21.35 m. Early Kuṣāṇa. L.22

3. Upper left corner of a large plate of Kerauli stone with scanty remains of script incised in four lines:

L.1: *mabārāja||*

L.2: *ma||*

L.3: *..||*

L.4: *śamikapa[ti]śa||*

27.3 × 21.3 × 6.2 cm. Kerauli stone. No. So I 245.
FS. 2 V 4.5/Cc 8.1, H. 21.10 m. Kuṣāṇa. L.20

4. Base of a sculpture with the remains of the feet of a standing human figure. The front of the base is strongly mutilated due to the later use as mortar. Of the originally presumably three lines of inscription only few letters are preserved in bad condition. As far as legible the inscription reads:

L.1: *bādb[ukasa pā]du[ka]kāye*

L.2: *a[bba].. ..[pratiṭha]*

L.3: *|| ..*

27.5 × 21.0 × 10.0 cm. Kerauli stone. No. So I 181.

FS. 2 V 9.5/Ca 10.7, H. 21.90 m. Kuṣāṇa. L.20

5. Fragment of a stone plate with remains of an inscription in four lines:

L.1: *|||putr(e)b(i)*

L.2: *|||anāṃtagbo*

L.3: *|||yaś*

L.4: *||| ..*

Size: 19.0 × 7.7 × 6.0 cm. Kerauli stone. No. So I 45.

FS. Surface find. According to the palaeography: Kuṣāṇa

6. Fragment of a cross-bar from a stone railing. One side reused with the purpose of carving a relief the sketch of which shows the contours of a Skanda figure. One of the lenticular lateral faces carries three lines of inscription:

L.1: *mabārājasya ka[n](iṣ)kaśya |||*

L.2: *gri 4 di 1 etāye purvāye |||*

L.3: *|||p(u)t(ra)s](ya)[s. mi]|||*

The lateral face of a cross-bar is a rare place to incise an inscription because it was hidden in the lenticular socket of its railing pillar. The later attempt to carve a relief has, unfortunately, damaged at least the third line, if not even the spot where the year “of the Mahārāja Kaniṣka” was engraved.

22.3 × 12.0 × 4.5 cm. Kerauli stone. No. So I 172.

FS. 2 IV 19.0/Cc 3.8, H. 21.50 m. Kuṣāṇa. L.(19)/18

7. Fragment of a stone plate with few letters of two lines of inscription:

L.1: *|||kaśya|||*

L.2: *|||put[ras](ya)|||*

Size: 17.5 × 7.7 × 6.3 cm. Mottled red sandstone.

No. So I 157. FS. 2 IV 10.0/Ca 13.7, H. 24.45 m.

Late Kuṣāṇa/Early Gupta. L.15



1



2a



2b



3a



3b



4



5



6



7



8a



8b



9



10



11



12



13



14a



14b



15



16



17



18



19



20



21



22a



22b



23



24



25



26



27



28



29



1



2



3



4

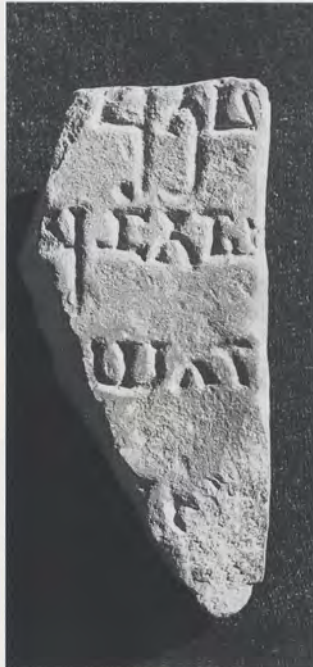

5



7

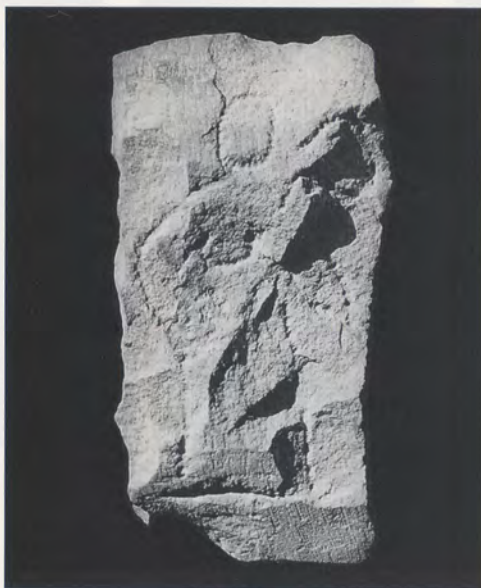

6a

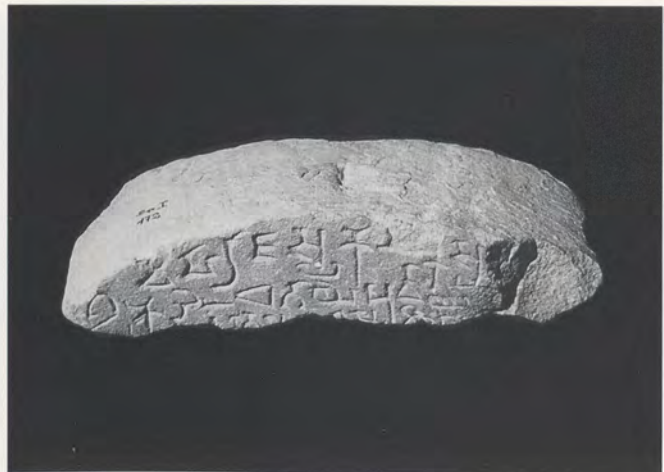

6b

K. COINS

292 coins were obtained from the main area of excavation out of which 25 are defaced. All the others are in a sufficient state of preservation to permit identification, either by their mintage or by safe stratification. 131 specimens are described and illustrated, 136 more have been allotted to their types in additional notes.

Period I (PGW-Levels) did not yield any coin. The levels of Period II provided uninscribed cast and die-struck coins as well as silver and copper punch-marked varieties. A small hoard of 42 copper punch-marked coins has already been expertly published by Dr. P. L. Gupta, as mentioned below.

Of special importance are four coins found in level 28, the level of transition from Period II to III. Two of these coins are un-inscribed types with the Ujjain symbol on its reverse (nos. 52–53), while the other two are the first inscribed specimens in the excavation, issued by Gomitra of Mathura (nos. 54–55). These are followed by the standard type coins of Sūryamitra in levels 27 to 26 (nos. 56–60d) which were also the find-levels of a further group of interesting specimens of (inscribed) copper coins: i.e. ten extremely small coins unearthed in 2 IV/Cc and 2 V/Ca, Cb. Five of them (nos. 63a; 65a–d) are too much corroded for direct identification; the other five (nos. 61–65) show at least traces of mintage although one side is, with one exception, either worn or split off. The stratification of these ten coins is unusually clear and beyond doubt. All these specimens are 1/8 Kāsharpanas of the time of Sūryamitra of Mathura. The impressions are different, there seem to exist at least two types. One shows obviously Lakṣmī standing facing, the second is rather remarkable: proven by no. 61, the Gaja-Lakṣmī motive, so well known from the reverse of Kṣatrapa coins, appears here on the obverse while the reverse shows a horse to *right*, i.e. the other way about than in the early Kṣatrapa types. This group of small coins was followed in Levels 26 and 25 by coins of Brahmamitra and Viṣṇumitra of Mathura (nos. 66–72).

From the levels of Period IV coins of the Kṣatrapas Hagāmaṣa, Rājuvula and Śoḍāsa were obtained side by side with issues of Rāmadatta (nos. 73–81).

The largest number of coins came from Period V (Kuṣāṇas). In addition to single specimens a jar has been found in house C of level 16, containing 120 copper coins, the bulk of them being issues of Vāsudeva I and his successors. During the first campaigns of excavation the coins found till then had been handed over to Dr. A. K. Srivastava, the then Numismatic Officer in the State Museum Lucknow, who gave a first interpretation. After the close of the excavation photographs of the whole find of Kuṣāṇa coins were given to Prof. Dr. Robert Göbl, Vienna, who was at that time preparing his comprehensive documentation of all Kuṣāṇa coins available so far. He used all but a few of the Sonkh specimens in his outstanding work "System und Chronologie der Münzprägung des Kushanreiches", Wien 1984, referred to in the description of the selected group of these coins below.

Period VI and VII/VIII yielded Muslim coins from the Turks to Aurangzeb (nos. 109–131), so kindly identified by Dr. A. K. Srivastava, as mentioned below.

Periods II to III. Coins from Levels 34 to 25

a) Earliest Uninscribed Copper Coins

1. *Obv.*: Crescent-on-hill, consisting of three arches in two tiers. Pellet on l.(?).

Rev.: Tree with ovate lanceolate leaves within railing.

Size 1.30 × 1.16 × 0.25 cm. Wt. 1.222 gm. Shape: square
No. So I 27. FS.3 I/Ca, H. 16.10–15.50m. Maurya. L.34/33

2. *Obv.*: Crescent-on-hill, consisting of three arches in two tiers. Pellet on r.

Rev.: Tree with lanceolate leaves within railing.

Size 1.22 × 1.18 × 0.42 cm. Wt. 2.938 gm. Shape: square.
No. So III H 33. FS.3 II/Ca, H. 16.30m. Maurya. L.33

3. *Obv.*: Crescent-on-hill, lower left arch partly broken off. Pellet on r.(?).

Rev.: Tree in railing.

Size 1.41 × 1.40 × 0.23 cm. Wt. 1.137 gm. Shape: square.
No. So I 98. FS.2 I/Bd, H. 18.95m. Late Maurya/Early Śuṅga C.P., L.32

4. *Obv.*: Lion l. before Indradhvaja symbol on l.

Rev.: Blank.

Size 1.50 × 1.66 × 0.32 cm. Wt. 4.589 gm. Shape: square.
No. So III H 248. FS.2 IV/Cc 8.6, H. 15.95m. Early Śuṅga C.P. L.32

5. *Obv.*: Lion (?) l. before Indradhvaja symbol on l. (cp. BMC: 237f.).

Rev.: Blank

Size 1.16 × 1.84 × 0.25 cm. Wt. 2.962 gm. Shape: rectangular.
No. So III H 255. FS. 2 IV/Cc, H. 16.02m. Early Śuṅga C.P., L.32

6. *Obv.*: Lion l. before Indradhvaja on l.

Rev.: Plain.

Size: 1.70 × 1.44 × 0.24 cm. Wt. 2.764 gm. Shape: square.
No. So III H 204. FS. 2 V/Cb, H. 18.85m. Found in Mitra-L.25.

b) Punch-marked Copper Coins

In Square 3 II 2.0/Ca 18.1, a common bowl containing 42 copper punch-marked coins has been found at the height of 16.30m, i.e. the early Śuṅga C.P. level 31. These coins (find nos. So III H 256–297) had been forwarded by the excavator to Dr. P. L. Gupta, the eminent Indian numismatist, for further studies. Dr. Gupta published the find under the title "Copper Punch-marked Coins from Sonkh" in JNSI, vol. XXXVII, 1975, pp. 1–12. As the photographs in the publication are partly overexposed they are printed here once more. For the historical interpretation and detailed description see Dr. Gupta's instructive contribution. For the purpose at hand the obverse and reverse situation as well as size and weight is repeated here. In the context of this publication the 42 coins are, consequently, listed as nos. 7 to 48.

7. (PLG.01) *Obv.*: Sun. *Rev.*: Blank.

Size: 1.86 × 1.55 × 0.28 cm. Weight: 4.4920 gm.

8. (PLG.02) *Obv.*: Sun. *Rev.*: Blank.

Size: 1.78 × 1.63 × 0.37 cm. Weight: 6.8674 gm.

9. (PLG.03) *Obv.*: Sun. *Rev.*: Blank.

Size: 2.08 × 1.66 × 0.37 cm. Weight: 5.7904 gm.

10. (PLG.04) *Obv.*: Sun; six-armed symbol. *Rev.*: Lion.

Size: 1.58 × 1.46 × 0.34 cm. Weight: 4.9722 gm.

11. (PLG.05) *Obv.*: Sun; crescent-on-hill. *Rev.*: Blank.

Size: 1.73 × 1.72 × 0.31 cm. Weight: 5.5500 gm.

12. (PLG.06) *Obv.*: Sun; crescent-on-hill. *Rev.*: Blank.

Size: 1.69 × 1.67 cm. Weight: 5.4162 gm.

13. (PLG.07) *Obv.*: Sun; crescent-on-hill. *Rev.*: Blank.

Size: 1.70 × 1.60 × 0.35 cm. Weight: 6.0932 gm.

14. (PLG.08) *Obv.*: Sun; crescent-on-hill. *Rev.*: Blank.

Size: 1.63 × 1.64 × 0.28 cm. Weight: 5.0742 gm.

15. (PLG.09) *Obv.*: Sun; crescent-on-hill. *Rev.*: Sun(?).
Size: 1.58 × 1.60 × 0.39 cm. Weight: 5.6428 gm.
16. (PLG.10) *Obv.*: Sun; tree in railing, without leaves. *Rev.*: Blank.
Size: 1.54 × 1.62 × 0.30 cm. Weight: 4.6148 gm.
17. (PLG.11) *Obv.*: Sun; dot with four crescents. *Rev.*: Blank.
Size: 1.84 × 1.66 × 0.40 cm. Weight: 6.6964 gm.
18. (PLG.12) *Obv.*: Sun; dot with four crescents. *Rev.*: Blank.
Size: 1.69 × 1.61 × 0.35 cm. Weight: 4.6769 gm.
19. (PLG.13) *Obv.*: Sun; dot with four crescents. *Rev.*: Blank.
Size: 1.65 × 1.51 cm. Weight: 4.6748 gm.
20. (PLG.14) *Obv.*: Sun; dot with four crescents. *Rev.*: Blank.
Size: 1.64 × 1.46 cm. Weight: 5.3554 grms.
21. (PLG.15) *Obv.*: Sun; dot with four crescents. *Rev.*: Blank.
Size: 1.78 × 1.66 × 0.31 cm. Weight: 5.4616 gm.
22. (PLG.16) *Obv.*: Sun; dot with four crescents. *Rev.*: Blank.
Size: 1.68 × 1.62 × 0.36 cm. Weight: 5.6810 gm.
23. (PLG.17) *Obv.*: Sun; dot with four crescents. *Rev.*: Blank.
Size: 1.83 × 1.64 × 0.35 cm. Weight: 5.5170 gm.
24. (PLG.18) *Obv.*: Sun; dot with four crescents. *Rev.*: Blank.
Size: 1.86 × 1.46 × 0.26 cm. Weight: 4.1728 gm.
25. (PLG.19) *Obv.*: Sun; (?). *Rev.*: Corroded.
Size: 1.61 × 1.68 × 0.40 cm. Weight: 4.9702 gm.
26. (PLG.20) *Obv.*: with four crescents; crescent-on-hill. *Rev.*: Blank.
Size: 1.74 × 1.57 cm. Weight: 5.0446 gm.
27. (PLG.21) *Obv.*: with four crescents; crescent-on-hill. *Rev.*: Blank.
Size: 1.79 × 1.54 cm. Weight: 5.4221 gm.
28. (PLG.22) *Obv.*: with four crescents; crescent-on-hill. *Rev.*: Blank.
Size: 1.69 × 1.60 cm. Weight: 4.6134 gm.
29. (PLG.23) *Obv.*: with four crescents; crescent-on-hill. *Rev.*: Blank.
Size: 1.73 × 1.55 × 0.37 cm. Weight: 5.6430 gm.
30. (PLG.24) *Obv.*: with four crescents; crescent-on-hill. *Rev.*: Blank.
Size: 1.67 × 1.58 × 0.36 cm. Weight: 6.8024 gm.
31. (PLG.25) *Obv.*: with four crescents; crescent-on-hill. *Rev.*: Blank.
Size: 1.81 × 1.64 cm. Weight: 5.2278 gm.
32. (PLG.26) *Obv.*: with four crescents; crescent-on-hill. *Rev.*: Blank.
Size: 1.69 × 1.53 × 0.34 cm. Weight: 4.9660 gm.
33. (PLG.27) *Obv.*: with four crescents; crescent-on-hill. *Rev.*: Blank.
Size: 1.83 × 1.63 × 0.32 cm. Weight: 5.8414 gm.
34. (PLG.28) *Obv.*: with four crescents; crescent-on-hill. *Rev.*: Blank.
Size: 1.77 × 1.66 × 0.41 cm. Weight: 5.6060 gm.
35. (PLG.29) *Obv.*: with four crescents; crescent-on-hill. *Rev.*: Blank.
Size: 1.80 × 1.61 × 0.30 cm. Weight: 5.7974 gm.
36. (PLG.30) *Obv.*: Dot with four crescents; crescent-on-hill. *Rev.*: One, not clear.
Size: 1.75 × 1.77 × 0.29 cm. Weight: 5.4409 gm.
37. (PLG.31) *Obv.*: Dot with four crescents; crescent-on-hill. *Rev.*: Indistinct incuse
Size: 1.68 × 1.57 × 0.33 cm. Weight: 5.1128 gm.
38. (PLG.32) *Obv.*: Dot with four crescents; tree in railing, with leaves. *Rev.*: Blank.
Size: 1.81 × 1.59 × 0.28 cm. Weight: 4.3220 gm.
39. (PLG.33) *Obv.*: Dot with four crescents; (?). *Rev.*: Blank
Size: 1.71 × 1.52 × 0.27 cm. Weight: 4.2008 gm.
40. (PLG.34) *Obv.*: Dot with four crescents; (?). *Rev.*: Blank.
Size: 1.69 × 1.68 × 0.40 cm. Weight: 6.2440 gm.
41. (PLG.35) *Obv.*: Dot with four crescents; (?). *Rev.*: Blank.
Size: 1.61 × 1.68 × 0.37 cm. Weight: 5.2674 gm.
42. (PLG.36) *Obv.*: Dot with four crescents; (?). *Rev.*: Crescent-on-hill.
Size: 1.74 × 1.57 cm. Weight: 4.8422 gm.
43. (PLG.37) *Obv.*: Dot with four crescents; (?). *Rev.*: One
Size: 1.59 × 1.58 × 0.38 cm. Weight: 5.8458 gm.
44. (PLG.38) *Obv.*: Scratches of symbol. *Rev.*: Blank.
Size: 1.55 × 1.71 × 0.32 cm. Weight: 5.2140 gm.
45. (PLG.39) *Obv.*: One indistinct symbol. *Rev.*: One indistinct symbol.
Size: 1.75 × 1.70 × 0.32 cm. Weight: 6.0654 gm.
46. (PLG.40) *Obv.*: Blank. *Rev.*: Blank.
Size: 1.87 × 1.56 × 0.33 cm. Weight: 5.3924 gm.
47. (PLG.41) *Obv.*: Blank. *Rev.*: Blank.
Size: 1.73 × 1.60 × 0.33 cm. Weight: 4.7830 gm.
48. (PLG.42) *Obv.*: Blank. *Rev.*: Blank.
Size: 1.70 × 1.63 × 0.34 cm. Weight: 6.1430 gm.
- c) Punch-marked Silver Coins*
49. *Obv.*: Sun; six-armed symbol; crescent-on-hill; 2 indistinct symbols.
Rev.: half, round reverse-mark (P. L. Gupta 1985: no. 473?).
Size 1.21 × 1.10 × 0.25 cm. Wt. 1.966 gm. Shape: rectangular
No. So I 99. FS. Trench 4, H. 18.80 m. In pit of ashes, ca L.32
50. *Obv.*: Sun; six-armed symbol; (?); caduceus(?); cross with central depression.
Rev.: Reverse-mark similar caduceus but without middle staff.
Size 1.25 × 1.26 × 0.26 cm. Wt: 2.172 gm. Shape: rectangular.
No. So III H 206. FS. 2 V/Cb, H. 1842 m. Found in Mitra-L.27/26
51. *Obv.*: Sun; six-armed symbol; three indistinct symbols.
Rev.: Reverse-mark: three armed windwheel (P. L. Gupta 1985: no. 140).
Size 1.63 × 1.17 × 0.25 cm. Wt: 3.136 gm. Shape: rectangular.
No. So III H 205. FS. 2 V/Cb, H. 18.95 m. Found in Mitra-L.25
- d) Uninscribed Copper Coins*
52. *Obv.*: Human figure standing facing before bull to left.
Rev.: Three circles as in Ujjain symbol but with central dot and without(?) linking rods.

Size 1.19–1.32 × 0.32 cm. Wt: 1.197 gm. Shape: circular.

No. So III H 222. FS. 2 IV/Cc, H. 17.07 m.

Late Śuṅga C.P./Earliest Mitra. L.28

53. *Obv.*: Indistinct.

Rev.: Ujjain symbol (double circles).

Size 1.80 × 1.62 × 0.31 cm. Wt: 3.958 gm. Shape: rectangular.

No. So III H 223. FS. 2 IV/Cc, H. 17.10 m.

Late Śuṅga C.P./Earliest Mitra. L.28

e) Inscribed Copper Coins

Gomitra

54. *Obv.*: Lakṣmī standing facing between ancillary symbols (i.e. two-tiered dotted “tree” on l., Ujjain-cross above “bowl-on-line” on r.).

Legend (above): [*Go*]mitasa

Rev.: Traces of three elephants.

Size 2.10–1.77 × 0.96 cm. Wt: 8.623 gm. Shape: circular.

No. So III H 245. FS. 3 I/Ca, H. 17.75 m. Earliest Mitra. L.28

55. *Obv.*: Lakṣmī standing facing between indistinct symbols.

Legend (above): *Gomitasa*

Rev.: Corroded. Traces of elephants.

Size 1.92–2.18 × 0.31/0.58 cm. Wt: 7.101 gm. Shape: circular.

No. So III H 300. FS. 2 IV/Cc, H. 17.05 m. Earliest Mitra. L.28

Sūryamitra

56. *Obv.*: Lakṣmī standing facing on indistinct base holding lotus in uplifted hand l. L. and r. ancillary symbols as described under no. 54.

Legend (above): *Suyamitasa*

Rev.: Three elephants.

Size 2.10–2.17 × 0.69 cm. Wt: 9.492 gm. Shape: circular.

No. So III H 254. FS. 2 V/Ca, H. 18.60 m. Mitra. L.26

57. *Obv.*: Lakṣmī standing facing, arm uplifted l., between two-tiered “tree” on l. and indistinct symbol on r.

Legend (above): [*Suyamita*]..

Rev.: Three elephants.

Size 1.90–2.12 × 0.64 cm. Wt: 8.640 gm. Shape: circular.

No. So III H 253. FS. 3 I/Cb, H. 18.35 m. Mitra. L.27/26

58. *Obv.*: Mutilated Lakṣmī standing facing between ancillary symbols on l. and r.

Legend (above): [*Suya*]mitasa

Rev.: Traces of elephants.

Size 2.00–2.12 × 0.89 cm. Wt: 8.494 gm. Shape: circular.

No. So III H 247. FS. 2 V/Ca, H. 18.60 m. Mitra. L.27/26

59. *Obv.*: Lakṣmī standing facing between ancillary symbols l. and r.

Legend (above): [*Su*]yam[itasa]

Rev.: Traces of elephants.

Size 2.08–2.15 × 0.89 cm. Wt: 10.062 gm. Shape: circular.

No. So III H 243. FS. 3 I/Cb, H. 18.35 m. Mitra. L.27/26

60. *Obv.*: Lakṣmī standing facing between ancillary symbols l. and r.

Legend (above): *Suyamitasa*

Rev.: Traces of elephants.

Size 2.02–2.10 × 0.79 cm. Wt: 8.831 gm. Shape: circular.

No. So III H 214. FS. 2 V/Cb, H. 19.30 m. Found in later L.23

a) *Obv.*: Lakṣmī standing facing between blurred symbols.

Legend (above): [*Suya*]mi[ta]..

Rev.: Split off.

Size 2.04–2.20 × 0.49 cm. Wt: 5.305 gm. Shape: circular.

No. So III H 213. FS. 2 IV/Cc, H. 18.30 m. Mitra. L.26

b) *Obv.*: Lakṣmī standing facing between blurred symbols.

Legend (above): ..yam[itasa]

Rev.: Traces of elephants.

Size 2.05–2.16 × 0.90 cm. Wt: 9.680 gm. Shape circular.

No. So III H 215. FS. 2 V/Ca, H. 18.40 m. Mitra. L.26

c) *Obv.*: Lakṣmī standing facing between blurred symbols.

Legend (above): [*Suyami*]..

Rev.: Traces of elephants.

Size 2.14–2.39 × 0.86 cm. Wt: 10.508 gm. Shape: circular.

No. So III H 216. FS. 2 V/Cb, H. 18.45 m. Mitra. L.26

d) *Obv.*: Lakṣmī standing facing between indistinct symbols.

Legend: corroded.

Rev.: Traces of elephants.

Size 2.14–2.34 × 1.15 cm. Wt: 11.306 gm. Shape: circular.

No. So III H 242. FS. 2 V/Ca, H. 18.55 m. Mitra. L.27/26

For nos. 61–65d see the remarks in the introduction of chapter above.

61. *Obv.*: Lakṣmī standing facing on a pedestal; raising elephant on l., r. unclear. Uncertain if legend above.

Rev.: Horse right.

Size 1.01–1.13 × 0.48 cm. Wt: 1.070 gm. Shape: circular.

No. So III H 217. FS. 2 V/Cb, H. 18.00 m. Mitra. L.27

62. *Obv.*: Lakṣmī standing facing; raising elephant on l., r. unclear. Uncertain if legend above.

Rev.: Horse right.

Size 1.02–1.11 × 0.56 cm. Wt: 1.282 gm. Shape: circular.

No. So III H 220. FS. 2 IV/Cc, H. 17.70 m. Mitra. L.27

63. *Obv.*: Lakṣmī standing facing; raising elephant l. and r.(?)

Rev.: Split off.

Size 0.83–0.85 × 0.17 cm. Wt: 0.197 gm. Shape: circular.

No. So III H 219. FS. 2 V/Cb, H. 18.15 m. Mitra. L.27

a) *Obv.*: Blurred.

Rev.: Horse right.

Size 0.77–0.92 × 0.48 cm. Wt: 0.684 gm. Shape: circular.

No. So III H 218. FS. 2 V/Ca, H. 18.30 m. Mitra. L.27

64. *Obv.*: Lakṣmī standing on l., facing; indistinct symbol on r. (presumably the Ujjain cross on indistinct base).

Rev.: Split off.

Size 1.04–1.07 × 0.36 cm. Wt: 0.572 gm. Shape: circular.

No. So III H 221. FS. 2 IV/Cc, H. 17.55 m. Mitra. L.27

65. *Obv.*: Lakṣmī standing facing; no space for symbol l., symbol r. Ujjain cross above indistinct base.

Rev.: For the most part split off.

Size 0.88–0.90 × 0.42 cm. Wt: 0.848 gm. Shape: circular.

No. So III H 228. FS. 2 V/Ca, H. 18.05 m. Mitra. L.27

a) *Obv.*: Blurred.

Rev.: Split off.

Size 0.86–0.89 × 0.24 cm. Wt: 0.210 gm. Shape: circular.

No. So III H 224. FS. 2 IV/Cc, H. 17.75 m. Mitra. L.27

b) *Obv.*: Blurred.

Rev.: Corroded.

Size 0.80–0.82 × 0.31 cm. Wt: 0.374 gm. Shape: circular.

No. So III H 226. FS. 2 IV/Cc, H. 17.70 m. Mitra. L.27

c) *Obv.*: Corroded.

Rev.: Split off.

Size 0.63–0.96 × 0.29 cm. Wt: 0.252 gm. Shape: circular.
No. So III H 227. FS. 2 V/Ca, H. 18.45 m. Mitra. L.27/26

d) *Obv.*: Corroded.

Rev.: Corroded.

Size 0.70–0.73 × 0.43 cm. Wt: 0.602 gm. Shape circular.
No. So III H 210. FS. 2 V/Cb, H. 18.12 m. Mitra. L.27

Brahmamitra

66. *Obv.*: Lakṣmī standing facing between ancillary symbols l. and r.

Legend (above): (*Bra[hmami](tasa)*)

Rev.: Traces of elephants.

Size 1.94–2.09 × 0.73 cm. Wt: 7.847 gm. Shape: circular.
No. So III H 212. FS. 2 V/Ca, H. 18.95 m. Mitra. L.26/25

67. *Obv.*: Lakṣmī standing facing, holding lotus in uplifted hand l. Ancillary symbols l. and, incomplete, r.

Legend (above): *Brahmamitasa*

Rev.: Traces of elephants.

Size 1.85–1.87 × 1.08 cm. Wt: 7.326 gm. Shape: circular.
No. So III H 246. FS. 2 V/Cb, H. 19.10 m. Mitra. L.25/24

68. *Obv.*: Lakṣmī standing facing, holding lotus in uplifted hand l. Ancillary symbols l. and r. blurred.

Legend (above): [*Bra*] *hmamitasa*

Rev.: Corroded.

Size 1.77–1.92 × 0.62 cm. Wt: 8.212 gm. Shape: circular.
No. So III H 251. FS. 2 V/Cb, H. 18.40 m. Mitra. L.25

69. *Obv.*: Lakṣmī standing facing between ancillary symbols l. and r. (blurred).

Legend (above): *Brahma[mi]..*

Rev.: Traces of elephants.

Size 1.53–1.58 × 0.31 cm. Wt: 3.035 gm. Shape: circular.
No. So III H 250. FS. 2 V/Cb, H. 18.40 m. Mitra. L.25

70. *Obv.*: Lakṣmī standing facing between blurred symbol l and (Ujjain cross-)symbol on indistinct base r.

Legend (above): [*Brahmamita*] *sa*

Rev.: Corroded.

Size 1.71–2.04 × 0.53 cm. Wt: 6.199 gm. Shape: circular.
No. So III H 249. FS. 2 V/Cb, H. 18.40 m. Mitra. L.25

Viṣnumitra

71. *Obv.*: Lakṣmī standing facing on indistinct base between blurred ancillary symbols.

Legend (above): [*Viṣnu*] *mitasa*

Rev.: Corroded.

Size 1.61–1.65 × 0.41 cm. Wt: 4.905 gm. Shape: circular.
No. So III H 244. FS. 2 V/Ca, H. 19.20 m. Mitra. L.25

72. *Obv.*: Figure and symbols blurred.

Legend (above) [*Viṣnu*] *mitasa*

Rev.: Corroded.

Size 1.89–1.90 × 0.76 cm. Wt: 5.743 gm. Shape: circular.
No. So III H 252. FS. 2 V/Cb, H. 18.40 m. Mitra. L.25

Period IV. Coins from Levels 25 to 23

Haḡāmaṣa

73. *Obv.*: Lakṣmī standing facing on horned circular symbol, holding lotus in uplifted hand, left. Ancillary symbols (BMC:183) on l. and r.

Legend: |||*pa[sa] Haḡ[ā]maṣasa*

Rev.: Horse l.

Size 1.85–1.97 × 0.29 cm. Wt: 4.722 gm. Shape: circular.
No. So III H 200. FS. 2 V/Cb, H. 19.35 m (top of sloping area).
Earliest Kṣātrapa. L.25

74. *Obv.*: Lakṣmī standing facing on base symbol(?), between ancillary symbol l. and r. (blurred).

Legend: |||*taṣa[sa]*|||

Rev.: Horse l.

Size 1.63–1.92 × 0.23 cm. Wt: 2.859 gm. Shape: circular.
No. So III H 202. FS. 2 IV/Cc, H. 18.60 m.
Earliest Kṣātrapa. L.25

Rāmadatta

75. *Obv.*: Lakṣmī standing between blurred symbols l. and r.

Legend: |||(*Rā[ma]datasa*)

Rev.: Traces of degenerated elephants.

Size 1.94–2.26 × 0.43 cm. Wt: 7.503 gm. Shape: circular.
No. So H 211. FS. 2 V/Cb, H. 18.35 m (foot of slope).
Earliest Kṣātrapa. L.25

76. *Obv.*: Lakṣmī standing facing in incuse square between partly blurred symbols l. and r. (= BMC:181).

Legend: [*Rā*] *jña Rāmada[t.]..*

Rev.: Traces of elephants.

Size 2.11–2.21 × 0.48 cm. Wt: 10.003 gm. Shape: circular.
No. So III H 230. FS. 2 V/Cb, H. 19.05 m. Kṣātrapa. L.24

77. *Obv.*: Lakṣmī standing facing in incuse square between ancillary symbols l. and r. (= BMC 181).

Legend: ||| [*da*] *tasa*

Rev.: Traces of elephants.

Size 2.04–2.23 × 0.36 cm. Wt: 5.734 gm. Shape: circular.
No. So III H 229. FS. 2 IV/Be, H. 20.90 m. Kṣātrapa. L.23

78. *Obv.*: Lakṣmī standing facing between blurred symbols

Legend: [*Rājña*] *Rāmadatasa*

Rev.: Corroded.

Size 1.69–1.87 × 0.68 cm. Wt: 6.332 gm. Shape: circular.
No. So III H 241. FS. 3 I/Cb, H. 19.65 m. Pit.

Rājwula

79. *Obv.*: Traces of standing Lakṣmī between symbols l. (blurred) and r. (= BMC: 187, Class II).

Legend: (*Rājwula*] *sa*

Rev.: Corroded.

Size 1.56–1.65 × 0.77 cm. Wt: 3.127 gm. Shape: circular.
No. So III H 199. FS. 2 V/Cb, H. 18.85 m. Kṣātrapa. L.24

Śoḡāsa

80. *Obv.*: Lakṣmī standing facing between ancillary symbols l. and r. (BMC:190).

Legend: [*Śo*] *ḡasa[sa]*

Rev.: Corroded.

Size 1.67–1.78 × 0.21 cm. Wt: 2.554 gm. Shape: circular.
No. So III H 192. FS. 2 V/Ca, H. 19.45 m. Kṣātrapa. L.24/23

81. *Obv.*: Traces of standing Lakṣmī between ancillary symbols l. (corroded) and r.

Legend: |||*taṣa[Śo]ḡasasa*

Rev.: Corroded.

Size 1.61–1.84 × 0.25 cm. Wt: 3.127 gm. Shape: circular.
No. So III H 193. FS. 2 V/Cb, H. 19.50 m. Kṣātrapa. L.23



Note: 11 more Śoḍāsa coins of comparable size and weight showing remains of Lakṣmī or symbols or of both, 10 found in L.23, 1 in L.22, registered under So III H 35; 194–198; 201; 203; 231; 232; 238.

82. *Obv.:* Indistinct coin? with unclear mintage. Stylized Brāhmī letters, difficult to read (see B.N.Mukherjee 1983:108f.).

Rev.: Defaced.

Size 1.68–1.70 × 0.22–0.31 cm. Wt: 3.755 gm. Shape: circular. No. So III H 302. FS. 2 V/Cb, H. 19.10m. Early Kṣatrapa. L.24

Period V. Coins from Levels 20 to 16

Wima Kadphises

83. *Obv.:* Corroded king standing l. sacrificing at altar.

Rev.: Śiva facing standing before bull r.

Size 2.47–2.60 × 0.45 cm. Wt: 13.231 gm. Shape: circular. No. So III H 163. FS. 2 V/Cb, H. 21.40m. Kuṣāṇa. L.20 Publ. Göbl 1984: no. 762/21.

Kaniṣka I

84. *Obv.:* King standing l. Details blurred.

Rev.: Male deity (MAO) l., r. arm stretched l.

Size 2.62–2.75 × 0.43 cm. Wt: 15.979 gm. Shape: circular. No. So III H 190. FS. 2 IV/Ca, H. 22.20m. Kuṣāṇa. L.20 Publ. Göbl 1984: no. 774/15.

85. *Obv.:* King standing l. Details corroded.

Rev.: NANA r., nimbate, holding sceptre.

Size 2.07–2.15 × 0.32 cm. Wt: 6.709 gm. Shape: circular. No. So III H 29. FS. 2 IV/Be, H. 19.00m. Kuṣāṇa. L.20 Publ. Göbl 1984: no. 778/3.

86. *Obv.:* King standing l. Details blurred.

Rev.: Wind-god running l., his hair loose, both arms stretched upwards, hands holding cloth.

Size 2.40–2.57 × 0.50 cm. Wt: 15.821 gm. Shape: circular. No. So III H 207. FS. 2 IV/Ca, H. 22.10m. Kuṣāṇa. L.20 Publ. Göbl 1984: no. 783/15.

87. *Obv.:* King standing l., sacrificing at altar, long spear in l. hand. Legend illegible.

Rev.: Wind-god running l., details corroded.

Size 2.46–2.62 × 0.36 cm. Wt: 10.723 gm. Shape: circular. No. So III H 31. FS. 2 IV/Cb, H. 21.90m. Kuṣāṇa. L.20 Publ. R. Göbl: 783/63.

Hwiṣka

88. *Obv.:* King on kline, half reclining.

Rev.: Moon-god l. with crescent behind shoulders.

Size 2.20–2.34 × 0.42 cm. Wt: 9.552 gm. Shape: circular. No. So III H 208. FS. 2 IV/Ca, H. 22.05m. Kuṣāṇa. L.20 Publ. R. Göbl: 835/32A.

89. *Obv.:* King on kline, half reclining. Traces of Greek inscription.

Rev.: Blurred deity standing to l.

Size 2.41–2.60 × 0.43 cm. Wt: 14.878 grms. Shape: circular. No. So III H 167. FS. 2 IV/Be, H. 22.10m. Kuṣāṇa. L.20

90. *Obv.:* King seated to front, facing r., nimbate and diademed.

Rev.: Sun-god (MIORO) l., ancillary (mountain) symbol l.

Size 2.10–2.25 × 0.33 cm. Wt: 6.695 gm. Shape: circular. No. So III H 18. FS. 2 IV/Ca, H. 23.70m. Kuṣāṇa. L.16 Publ. R. Göbl: 937/11.

91. *Obv.:* King seated to front facing r., nimbate and diademed.

Rev.: Sun-god (MIIRO) l., ancillary symbol l.

Size 1.86–2.00 × 0.42 cm. Wt: 6.573 gm. Shape: circular. No. So III H 39. FS. 2 IV/Be, H. 23.80m (found in jar). Kuṣāṇa. L.16 Publ. R. Göbl: Type 934

92. *Obv.:* King r., diademed and nimbate, riding on elephant, holds spear and elephant-goad.

Rev.: Sun-god l., ancillary symbol (on mountain) l.

Size 2.02–2.17 × 0.45 cm. Wt: 7.389 gm. Shape: circular. No. So III H 38. FS. 2 IV/Be, H. 23.80m (found in jar). Kuṣāṇa. L.16. Publ. R. Göbl: Type 933 or 936.

Vāsudeva

93. *Obv.:* King standing, nimbate, offering at altar to l., trident l., spear r.

Rev.: Two-armed Śiva standing facing, noose l., spear r., behind him bull standing to l.

Size 2.09–2.15 × 0.34 cm. Wt: 7.882 gm. Shape: circular. No. So III H 56. FS. 2 IV/Be, H. 23.80m (found in jar). Kuṣāṇa. L.16 Publ. R. Göbl: 1003/12.

Note: One more coin of same type: So III H 50; Göbl 1003/13.

94. *Obv.:* King standing facing l., nimbate, offering at altar l., trident l., spear r.

Rev.: Two-armed Śiva standing facing, noose l., spear r., behind him bull standing to l.

Size 1.96–2.29 × 0.40 cm. Wt: 8.255 gm. Shape: circular. No. So III H 51. FS. 2 IV/Be, H. 23.80m (found in jar). Kuṣāṇa. L.16 Publ. R. Göbl: 1004/22.

Note: One more specimen of same type: So III H 42; Göbl 1004/23.

95. *Obv.:* King standing facing l.(?), nimbate, offering at altar l., trident-cum-battle axe l., spear r.

Rev.: Two-armed Śiva standing before bull to l.

Size 1.76–1.97 × 0.36 cm. Wt: 6.588 gm. Shape: circular. No. So III H 47. FS. 2 IV/BE, H. 23.80m (found in jar). Kuṣāṇa. L.16 Publ. R. Göbl: 1007/7.

96. *Obv.:* King standing, nimbate(?), trident l, club(?) r.

Rev.: Two-armed Śiva standing facing before bull to l.

Size 1.85–2.08 × 0.35 cm. Wt: 6.654 gm. Shape: circular. No. So III H 58. FS. 2 IV/Be, H. 23.80m (found in jar). Kuṣāṇa. L.16 Publ. R. Göbl: 1008/13.

Note: 4 more specimens of same type: So III H 40; 59; 60; 170. Göbl: 1008/11,12,14,15

97. *Obv.:* King standing facing l., nimbate.

Rev.: Two-armed Śiva standing facing, behind him bull to l.

Size 1.86–2.04 × 0.35 cm. Wt: 6.127 gm. Shape: circular. No. So III H 53. FS. 2 IV/Be, H. 23.80m (found in jar). Kuṣāṇa. L.16. Publ. R. Göbl: 1009/5.

98. *Obv.:* King standing facing l., nimbate.

Rev.: Two-armed Śiva standing facing, behind him bull to l.

Size 1.80–2.00 × 0.36 cm. Wt: 6.196 gm. Shape: circular. No. So III H 54. FS. 2 IV/Be, H. 23.80m (found in jar). Kuṣāṇa. L.16 Publ. R. Göbl: 1009/4.

Vāsudeva Successors

99. *Obv.*: King standing facing l., nimbate.
Rev.: Two-armed Śiva standing facing, behind him bull to l.
 Size 1.83–1.94 × 0.32 cm. Wt: 5.938 gm. Shape: circular.
 No. So III H 52. FS. 2 IV/Be, H. 23.80 m (found in jar). Kuṣāṇa. L.16
 Publ. R. Göbl: 1010/122.
Note: 8 more specimens of same type registered as So III H 34; 45; 48; 49; 55; 57; 63; 169. Publ.R. Göbl: 1010/120–121; 123–128.
100. *Obv.*: King standing facing l., nimbate, offering at altar.
Rev.: Two-armed Śiva standing facing, behind him bull to l.
 Size 2.00–2.16 × 0.31 cm. Wt: 5.904 gm. Shape: circular.
 No. So III H 61. FS. 2 IV/Be, H. 23.80 m (found in jar). Kuṣāṇa. L.16
 Publ. R. Göbl: 1011A/8.
Note: One more specimen: So III H 171 = Göbl: 1011/15.
101. *Obv.*: King standing facing l., nimbate, offering at altar, trident r.
Rev.: Two-armed Śiva standing facing, behind him bull to l.
 Size 2.10–2.30 × 0.45 cm. Wt: 9.756 gm. Shape: circular.
 No. So III H 27. FS. 2 IV/Ca, H. 23.47 m. Kuṣāṇa. L.16
 Publ. R. Göbl: 1012/1.
102. *Obv.*: King standing facing l., nimbate, offering at altar, trident r.
Rev.: Two-armed Śiva standing facing, behind him bull to l.
 Size 1.78–1.93 × 0.71 cm. Wt: 5.682 gm. Shape: circular.
 No. So III H 189. FS. 3 I/Ca, H. 22.30 m. Kuṣāṇa. L.18
 Publ. R. Göbl: 1014/10.
Note: One more specimen: So III H 28 = Göbl: 1014/11.
103. *Obv.*: Traces of standing king.
Rev.: Seated goddess Ardoksho on throne to front.
 Size 1.89–1.94 × 0.37 cm. Wt: 6.322 gm. Shape: circular.
 No. So III H 93. FS. 2 IV/Be, H. 23.80 m (found in jar). Kuṣāṇa. L.16
 Publ. R. Göbl: 1015/23.
Note: One more specimen: So III H 112 = Göbl: 1015/24
104. *Obv.*: King standing facing l., nimbate, trident r.
Rev.: Seated goddess Ardoksho on throne to front.
 Size 1.69–2.03 × 0.45 cm. Wt: 7.875 gm. Shape: circular.
 No. So III H 119. FS. 2 IV/Be, H. 23.80 m (found in jar). Kuṣāṇa. L.16
 Publ. R. Göbl: 1016/7
105. *Obv.*: King standing l., nimbate, offering at altar, trident l., spear r.
Rev.: Seated goddess Ardoksho on throne.
 Size 1.88–2.06 × 0.35 cm. Wt: 7.177 gm. Shape: circular.
 No. So III H 74. FS. 2 IV/Be, H. 23.80 m (found in jar). Kuṣāṇa. L.16
 Publ. R. Göbl: 1017/124.
106. *Obv.*: King standing l., nimbate, offering at altar, trident l.
Rev.: Seated goddess Ardoksho on throne.
 Size 1.91–2.10 × 0.37 cm. Wt: 7.849 gm. Shape: circular.
 No. So III H 69. FS. 2 IV/Be, H. 23.80 m (found in jar). Kuṣāṇa. L.16
 Publ. R. Göbl: 1017/113.
Note: 98 more specimens of same type registered under So III H 37; 41; 43; 44; 46; 64–68; 70–73; 75–92; 94–111; 113–118; 120–156; 172–176. Publ. R. Göbl: all 1017.

Vīrasena

107. *Obv.*: Tree in railing, Nandyāvarta symbol r. and l.
 Legend: *nasa*
Rev.: Crude standing figure of Lakṣmī holding stalk of flower in her l. hand.
 Size 1.10 × 1.12 × 0.21 cm. Wt: 1.654 gm. Shape: rectangular.
 No. So III H 158. FS. 2 V/Ca, H. 20.86 m. Kuṣāṇa. Pit from L.16/15.
Note: One more specimen of Vīrasena type: So III H 237. L.17/16.

*Periods VI–VII/VIII. Coins from Levels 13 to 6**Vigraḥapāla and Successors*

108. AR.
Obv.: Crude bust of king to right: turreted and with crescent behind. Dot in crescent below bust. Legend restricted to two blurred characters: before face *Śrī*, below *Śrī Vi*.
Rev.: Fire altar and attendances.
10th cent. AD. Cp. M. Mitchiner, 1979, p.61, nos.392–393.
 Size 1.62 × 1.67 × 0.23 cm. Wt: 2.902 gm. Shape: circular.
 No. So III H 17. FS. 2 IV 8.47/Cb 5.25, H. 25.55 m. Medieval. Found under a floor in Level 9, but presumably passed on from Level 11.

Muslim Coins

- From levels 13/12 to 6 follow the finds of Muslim coins. Due to heavy disturbances in these levels the findspot of the coins does not help to determine the exact level to which each coin belongs. The author wishes to express his sincere thanks to Dr. A.K.Srivastava, former Numismatic Officer in the State Museum Lucknow, for the identification of the coins. The description given here comprises Metal, Dynasty, Ruler, Mint/Type, Date, Size, Weight and Shape, as far as available. For the legend see the references to relevant catalogues.
109. Æ. Turks. Iltutmish. Hazrat Delhi.
 Legend within plain and dotted circle = DMC (Wright 1936) no. 134.
 Size 1.51–1.67 × 0.27 cm. Wt: 3.914 gm. Shape: circular.
 No. So III H 184. FS. 2 V/Cc, H. 23.40 m.
110. B. Khaljis. Jalaluddin Firuz II. Mint and date: –.
 Legend in square and in square + around = DMC no. 290 A.
 Size 1.61–1.65 × 0.24 cm. Wt: 3.392 gm. Shape: circular.
 No. So III H 185. FS. Surface find.
111. Æ. Tughluqs. Firuz Shah III. Delhi, Darul-mulk.
 Legend in circle = DMC no. 714.
 Size 1.40–1.52 × 0.35 cm. Wt: 4.205 gm. Shape: circular.
 No. So III H 36. FS. Surface find.
112. Æ. Tughluqs. Mahmud II. Delhi, Darul-mulk.
 Legend in circle = DMC no. 870.
 Size 1.31–1.38 × 0.40 cm. Wt: 4.253 gm. Shape: circular.
 No. So III H 22. FS. 2 III/Cc.
113. Æ. Lodis. Ibrahim Shah II. Date: 932.
 Legend = DMC no. 1022.
 Size 1.00–1.20 × 0.37 cm. Wt: 2.375 gm. Shape: circular.
 No. So III H 186. FS. 2 IV/Cb.
114. Æ. Suris. Sher Shah. Mint/Date –.
 Legend = DMC no. 1112.
 Size 2.20–2.24 × 0.61 cm. Wt: 18.732 gm. Shape: circular.
 No. So III H 9. FS. 2 IV/Ca, H. 25.93 m.

115. Æ. Suris. Sher Shah. Shergarh Fort. Date 950.
Legend = DMC 1151
Size 2.23–2.30 × 0.60 cm. Wt: 19.820 gm. Shape: circular.
No. So III H 15. FS. 2 III/Ca, H. 25.85 m.
116. Æ. Suris. Sher Shah. Shergarh Delhi. Date 950.
Legend = DMC 1167
Size 2.31–2.33 × 0.64 cm. Wt: 19.528 gm. Shape: circular.
No. So III H 3. FS. 2 IV/Cb, H. 25.70 m.
117. Æ. Suris. Sher Shah. Narnol. Date 950.
Legend = DMC no. 1202.
Size 2.25–2.28 × 0.66 cm. Wt: 19.412 gm. Shape: circular.
No. So III H 4. FS. 2 V/Ca, H. 26.11 m.
118. Æ. Suris. Sher Shah. Narnol. Date:(9)51.
Legend = DMC no. 1206
Size 2.30–2.36 × 0.60 cm. Wt: 20.998 gm. Shape: circular.
No. So III H 16. FS. 2 IV/Ca, 24.85 m.
119. Æ. Suris. Islam Shah. Mint/Date –.
Legend = DMC no. 1428. 1/8 paisa.
Size 1.19–1.22 × 0.28 cm. Wt: 2.273 gm. Shape: circular.
No. So III H 19. FS. 2 III/Cb, H. 24.10 m.
120. Æ. Mughal. Akbar. Agra, Darul-khilafat. Date 970.
Legend = LMC no. 855.
Size 2.11–2.25 × 0.70 cm. Wt: 19.322 gm. Shape: circular
No. So III H 23. FS. 2 IV/Cb, H. 24.05 m.
121. Æ. Mughal. Akbar. Narnol. Date 985.
Legend = LMC no. 1128
Size 1.98–2.10 × 0.81 cm. Wt: 20.191 gm. Shape: circular.
No. So III H 5. FS. 2 IV/Be.
122. Æ. Mughal. Akbar. Narnol type. Date –.
Size 1.94–2.00 × 0.87 cm. Wt: 19.611 gm. Shape: circular.
No. So III H 14. FS. 2 III/Ca, H. 25.90 m.
123. Æ. Mughal. Akbar. Mint: –. Date: 971.
Size 2.00–2.11 × 0.80 cm. Wt: 19.916 gm. Shape: circular.
No. So III H 25. FS. 2 IV/Cb.
124. Æ. Mughal. Akbar. Mint –. Date: 97x.
Size 1.88–1.98 × 0.87 cm. Wt: 19.507 gm. Shape: circular.
No. So III H 20. FS. 2 IV/Ca, H. 24.65 m.
125. Æ. Mughal. Akbar. Mint/Date –.
Size 1.86–1.93 × 0.90 cm. Wt: 20.012 gm. Shape: circular.
No. So III H 10. FS. 2 IV/Ca, H. 26.05 m.
126. Æ. Mughal. Akbar. Mint –. Date: 97x.
Size 1.85–1.97 × 0.94 cm. Wt: 20.127 gm. Shape circular.
No. So III H 7. FS. 2 IV/Be.
127. Æ. Mughal. Jahangir. Mint/Date –.
Size 1.81–2.02 × 0.88 cm. Wt: 19.645 gm. Shape: circular.
No. So III H 11. FS. 2 IV/Ca, H. 26.02 m.
128. Æ. Mughal. Jahangir. Agra. Date:-ry.8.
Legend in triple circle = LMC no. 1778.
Size 2.45–2.50 × 0.50 cm. Wt: 18.468 gm. Shape: circular.
No. So III H 12. FS. 2 IV/Ca, H. 26.02 m.
129. Æ. Mughal. Jahangir. Agra. Date: 1020.
Legend = LMC no. 1777. Counter-struck on a Suri coin.
Size 2.16–2.29 × 0.65 cm. Wt: 19.372 gm. Shape: circular.
No. So III H 8. FS. 2 IV/Be.
130. Æ. Mughal. Shahjahan. Bairat. Date: 104x.
Legend = LMC no. 2435. All the three Alifs elongated.
Size 2.04–2.15 × 0.80 cm. Wt: 20.427 gm. Shape: circular.
No. So III H 2. FS. Surface find.

131. AR. Mughal. Aurangzeb Alamgir. Akbarnagar.
Date:xx17–49. Legend = LMC no. 2714.
Size 2.00–2.08 × 0.39 cm. Wt: 11.746 gm. Shape: circular.
No. So III H 13. FS. 2 IV/Cb, H. 26.27 m.

L. COIN MOULDS

In the Levels 23 to 22, i.e. Late Kṣatrapa to Early Kuṣāṇa, 26 fragments of circular coin moulds of fine and hard grey terracotta for casting punch-marked coins have been found. The technique of using such moulds has been clearly described by B. Sahni (1945: 44ff.; 59f.). As most of the Sonkh fragments are rather tiny, a group of six better preserved pieces may stand here for all.

1. Fragment of a top or bottom disc of a coin mould set. The blank outer face shows concentric grooves made by facing on a turntable. On the edge, adhering traces of luting are visible. The inner face preserves two complete and the halves of two more coin sockets of rectangular and rounded shape. From a hole in the centre short channels for leading the metal into the sockets are grooved. One socket is blank, the other shows indistinct traces of symbols (?).

L. 5.5 cm. Colour: grey. No. So III A 2518.
FS. 2 V/Cb, H. 20.40 m. Early Kuṣāṇa. L.22

2. Fragment of an inner disc of a set of moulds. Remains of three and four coin sockets on each face respectively. Traces of symbols in two sockets of the face a. In the elliptical one sun and six-armed symbol can be identified. In face b three sockets seem to be blank, while in the large round one two lenticular marks are recognizable. Channels from the central hole leading straight to each socket.

L. 5.4 cm. Colour: grey. No. So III A 2552.
FS. 2 V/Cb, H. 19.20 m. Late Kṣatrapa. L.23

3. Fragment of inner disc of a set of moulds. Remains of three coin-sockets of rectangular and round shape on both sides. All sockets seem to be blank. No channels from centre, the depressions are connected in pairs, as indicated on one of the faces.

L. 4.4 cm. B. 2.4 cm. Colour: grey. No. So III A 2526.
FS. 2 V/Cb, H. 20.40 m. Early Kuṣāṇa. L.22

4. Small fragment of an inner disc of a set of coin moulds. Remains of two depressions on each face. One shows blank sockets, the other the outlines of two human figures with an elevated circle, perhaps another symbol, in between them.

L. 3.1 cm. B. 2.5 cm. Colour: grey. No. So III A 2516.
FS. 2 V/Cb, H. 20.40 m. Early Kuṣāṇa. L.22

5. Small fragment of an inner disc of a set of coin moulds. Remains of two sockets on each face. Three of them are blank, one shows a human figure as in no. 4, and perhaps a second one of a row of three figures standing side by side.

L. 3.6 cm. B. 2.4 cm. Colour: grey. No. So III A 2521.
FS. 2 V/Cb, H. 20.40 m. Early Kuṣāṇa. L.22

6. Small fragment of an inner disc of a set of coin moulds. Remains of one and two sockets on each face respectively. Two are blank, the single one shows three human figures standing side by side.

L. 2.3 cm. B. 2.4 cm. Colour: grey. No. So III A 2515.
FS. 2 V/Cb, H. 20.40 m. Early Kuṣāṇa. L.22

Note: 20 more fragments of discs of a set of coin moulds are registered under So III A 2511–14; 2517; 2519–20; 2522–25; 2527–34.



1



2



3

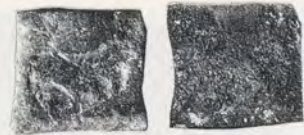

4



5



6



7



8



9

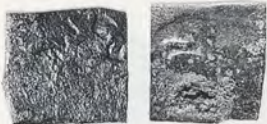

10



11

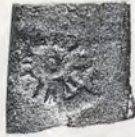

12



13



14



15



16



17



18



19



20



21



22



23



24

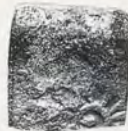

25



26



27



28



29



30



31



32



33



34



35

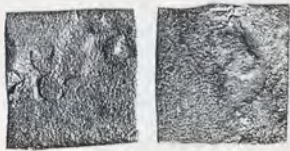

36



37



38



39



40

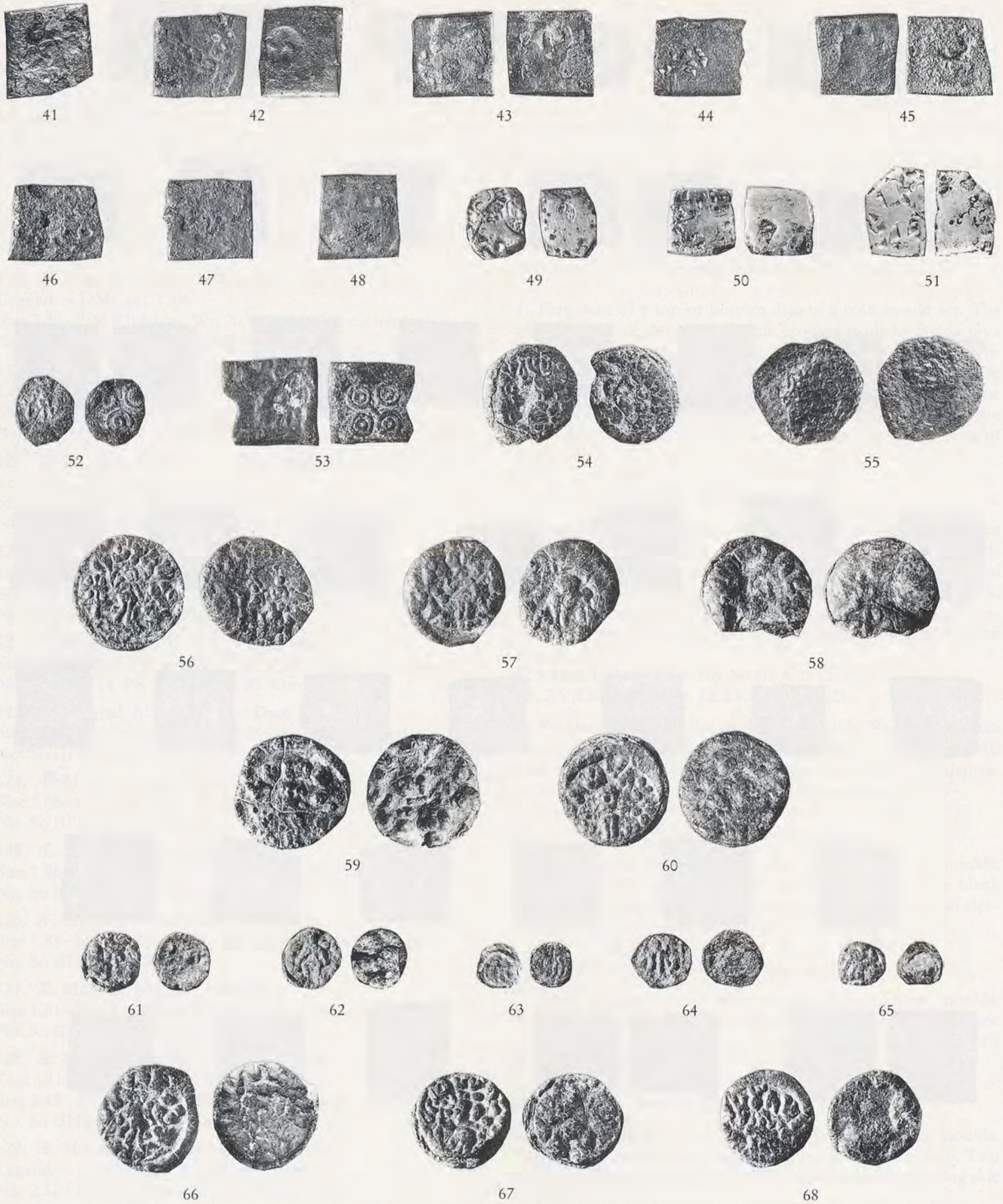

Coins, Period II/III. Punch-marked Copper (41-48), Punch-marked Silver (49-51), Uninscribed Copper, Per. II (52-53), Inscribed Copper, Per. III (54-68). 1/1



69



70

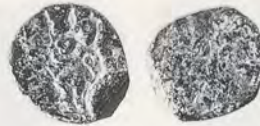

71



72



73



74



75



76



77



78



79



80



81



82



83



84



85



86



87



88



89



90



91



92



93



94



95



96



97



98



99



100



101



102



103



104



105



106



107

108



109

110

111

112

113



114

115

116



117

118

119

120



121

122

123

124



125

126

127

128



129

130

131

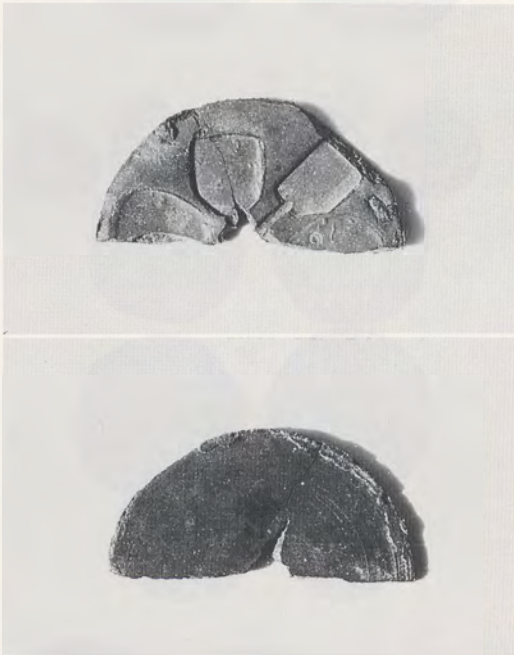

1a, b



2a, b

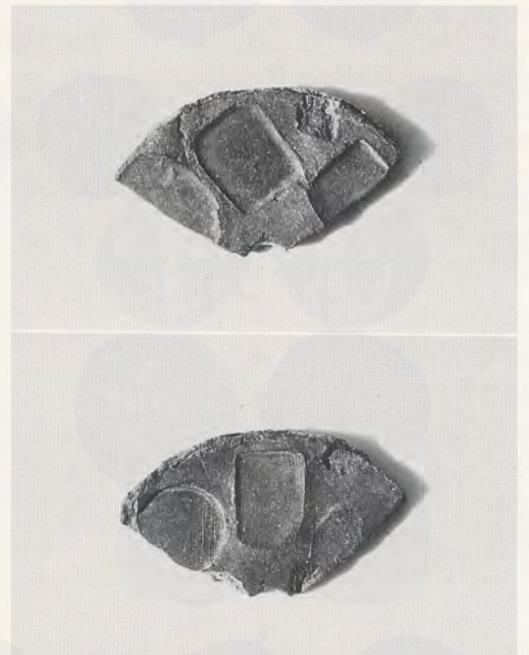

3a, b

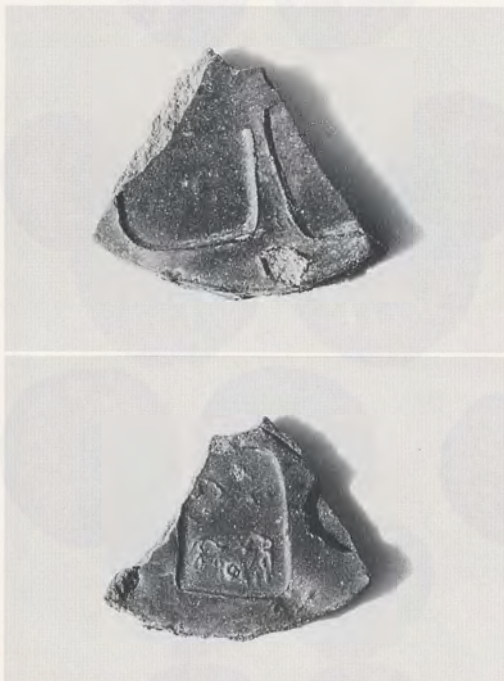

4a, b



5a, b



6a, b

M. SOME STRUCTURAL OBJECTS

The structural situation in the diverse levels has been described in detail in the first chapters above. The size of bricks used for different buildings has been mentioned in connection with the structural units. It may be helpful to bring together these data from the earliest period of measurable bricks in levels 29/28 upto level 16, the last level of undisturbed structures in Sonkh.

Level 29/28 Mud-bricks	45 × 23 × 6 cm
	43 × 23 × 8 cm
	42 × 23 × 6 cm
	35 × 23 × 6 cm
Level 28 Mud-bricks	42 × 28 × 7 cm
Level 27 Baked bricks	42 × 28 × 7 cm
	48 × 23 × 7 cm
Level 26/25 Baked bricks	42 × 28 × 7 cm
Level 24/23 Baked bricks	42 × 26 × 6 cm
	40 × 25 × 5 cm
Level 22 Baked bricks	41 × 25 × 6 cm
Level 21/16 Baked bricks	38 × 24 × 6 cm
	37 × 23 × 5 cm

Noticeable among the single objects hailing from structures is an indistinct fragment of mosaic of the early Maurya period (no. 1), the other materials are lumps of clay with reed or bamboo impressions (nos. 2–5), a number of roof-tiles of different shapes (nos. 6–21), and three large pinnacles (nos. 22–24), all from level 27.

1. Fragment of a mosaic consisting of pieces of coloured flint pressed into tempered clay. It is uncertain if this piece is part of a pavement.

18.5 × 16.3 × 4.8 cm. Coloured stones in grey lump of clay.
No. So III G 104. FS.2 IV/Cc, H. 14.65 m. Early Maurya. L.35

2. Partly fired clay lump with impressions on both sides. On one side clear impressions of reed, on the other a cylindrical impression, perhaps of bamboo.

14.5 × 14.1 × 6.8 cm. Colour: grey. No. So III G 187.
FS. 2 V/Cb, H. 18.10 m. Mitra. L.27

3. Lump of clay with impressions on both sides. Very similar to no. 2.

Size: 21.2 × 19.4 × 8.3 cm. Colour: grey.
No. So III G 188. FS. 2 V/Cb, H. 18.20 m. L.27

Note: 2 more fragments of both sides impressed lumps of clay under So III G 192; 196.

4. Lump of clay with circular impression which indicates that the piece was applied on some cylindrical support like bamboo.

Size: 21.2 × 15.6 × 8.3 cm. Colour: grey.
No. So III G 189. FS. 2 V/Cb, H. 18.20 m. Mitra. L.27

5. Lump of clay with circular impression, perhaps of a rod.

Size: 17.0 × 11.1 × 6.7 cm. Colour: grey.
No. So III G 197. FS. 2 V/Cb, H. 18.05 m. Mitra. L.27

6. Burnt roof-tile with four carefully impressed grooves. Hand-made.

Size: 33.19 × 19.12 × 2.31 cm. Colour: red-brown.
No. So III G 21. FS. 2 V/Cb, H. 18.20 m. Mitra. L.27

7. Hand-made burnt roof-tile with five grooves.

Size: 33.8 × 22.1 × 2.15 cm. Colour: red-brown.
No. So III G 9. FS. 2 V/Cb, H. 18.15 m. Mitra. L.27
Note: 9 more tiles registered under So III G 15; 22; 78; 93; 106; 117; 123; 133; 136. Found in 2 V/Cb and 2 V/Cc. Length 32–37 cm, width 20–25 cm, depth 1.9–2.4 cm.

8. Burnt roof-tile with six carelessly impressed longitudinal grooves, three fingerstrokes, and a semicircular impression on the narrow side.

Size: 32.13 × 21.00 × 1.95 cm. Colour: red-brown.
No. So III G 25. FS. 2 V/Cb, H. 18.25 m. Mitra. L.27

9. Burnt roof-tile with three carefully impressed longitudinal grooves and a scratched mark on one corner. Hand-made.

Size: 35.6 × 20.9 × 2.1 cm. Colour: red-brown.
No. So III G 114. FS. 2 V/Cc, H. 18.38 m. Mitra. L.27

10. Fragmentary burnt roof-tile with seven longitudinal grooves and a hole at the edge of the narrow upper side for anchoring the tile to the roof. Hand-made.

Size: 33.8 × 23.7 × 2.1 cm. Colour: red-brown.
No. So III G 45. FS. 2 V/Cb, H. 18.10 m. Mitra. L.27

11. Hand-made burnt roof-tile with five longitudinal grooves and two holes on the narrow upper side for anchoring it to the roof.

Size: 34.38 × 22.19 × 1.93 cm. Colour: red-brown.
No. So III G 1. FS. 2 V/Cb, H. 18.20 m. Mitra. L.27
Note: 3 more tiles with two holes under So III G 29; 32; 112.

12. Hand-made burnt roof-tile with three longitudinal grooves, a stripe decorated with scratched wavy lines, and a single separate wavy line. Traces of fingerstrokes on the narrow upper side of the tile.

Size: 33.4 × 22.0 × 2.2 cm. Colour: red-brown.
No. So III G 124. FS. 2 V/Cb, H. 18.00 m. Mitra. L.27

13. Burnt narrow roof-tile with two moulded floral rosettes.

Size: 26.1 × 11.2 × 1.7 cm. Colour: dull red.
No. So III G 150. FS. 2 V/Cc, H. 18.40 m. Mitra. L.27

14. Fragment of a burnt narrow roof-tile with remains of two impressed lotus rosettes.

Size: 9.8 × 5.9 × 1.5 cm. Colour: dull red
No. So III A 3111. FS. 2 V/Ca, H. 18.40 m. Mitra. L.27

15. Fragment of burnt tile with crudely impressed floral rosette.

Size: 21.5 × 17.5 × 6.0 cm. Colour: red-brown.
No. So III A 3476. FS. 2 V/Cb, H. 18.35–18.10 m. Mitra. L.27

16. Hand-made and burnt arched roof-tile with five grooves on the narrow upper side.

Size: 41.5 × 31.0 × 7.2 cm. Colour: red-brown.
No. So III G 108. FS. 2 V/Cc, H. 18.58–18.45 m. Mitra. L.27
Note: One more perfectly identical tile: So III G 139.

17. Fragment of hand-made and burnt arched roof-tile with four grooves each at the narrow upper side and across the tile.

25.6 × 19.8 × 3.4 cm. Colour: red-brown. No. So III G 151.
FS.2 V/Cc, H. 18.75–18.45 m. Mitra. L.27/26

18. Carinated burnt roof-tile. Plain surface.

Size: 32.3 × 13.6 × 9.8 cm. Colour: red-brown.
No. So III G 141. FS. 2 V/Cc, H. 18.45 m. Mitra. L.26

19. Narrow arched roof-tile with wavy lines.

Size: 24.4 × 13.5 × 10.5 cm. Colour: red-brown.
No. So III G 88. FS. 2 V/Cc, H. 18.95–18.65 cm. Mitra. L.26

20. Fragment of carinated roof-tile with five grooves and two holes on one wing, and wavy finger-lines on the other.

Size: 32.79 × 23.02 × 7.53 cm. Colour: red-brown.
No. So III G 14. FS. 2 V/Cb, H. 18.20 m. Mitra. L.27

21. Fragment of an object found closely together with roof-tiles and pinnacles. Two concentric grooves around wide holes.
20.8 × 16.5 × 13.1 cm. Red-brown. No. So III G 135.
FS. 2 V/Cc, H. 18.15–18.00m. Mitra. L.27
22. Slightly damaged but complete pinnacle with three broad ribs having protruding edges, from a roof in Sūryamitra-L.27
Size: H. 37.0cm. Diam. 14.1cm. Colour: brick-red.
No. So III G 100. FS.2 V/Cb, H. 18.10m. Mitra. L.27
23. Pinnacle similar to No. 22 but without the small upper rib.
Size: H. 35.0cm. Diam. 13.8cm. Colour: red-brown.
No. So III G 102. FS.2 V/Cb, H. 18.05m. Mitra. L.27
24. Pinnacle without top. If it was intended to be closed, a lid must have been put on.
Size: H. 34.9cm. Diam. 16.4cm. Colour: red-brown.
No. So III G 101. FS. 2 V/Cb, H. 18.10m. Mitra. L.27

3. SOME STRUCTURAL OBJECTS

The structural situation in the lower levels has been described in detail in the first chapter. The size of bricks used for the walls and pillars has been mentioned in connection with the structural units. It may be helpful to bring together here those parts of the record which are noteworthy. Bricks in levels 20.55 and 20.50 are of the same level of industrial structure as found.

Level 20.55. Bricks 20.55 × 13.5 × 7.5 cm.

Level 20.50. Bricks 20.50 × 13.5 × 7.5 cm.

Level 20.45. Bricks 20.45 × 13.5 × 7.5 cm.

Level 20.40. Bricks 20.40 × 13.5 × 7.5 cm.

Level 20.35. Bricks 20.35 × 13.5 × 7.5 cm.

Level 20.30. Bricks 20.30 × 13.5 × 7.5 cm.

Level 20.25. Bricks 20.25 × 13.5 × 7.5 cm.

Level 20.20. Bricks 20.20 × 13.5 × 7.5 cm.

Level 20.15. Bricks 20.15 × 13.5 × 7.5 cm.

Level 20.10. Bricks 20.10 × 13.5 × 7.5 cm.

Level 20.05. Bricks 20.05 × 13.5 × 7.5 cm.

Level 20.00. Bricks 20.00 × 13.5 × 7.5 cm.

Level 19.95. Bricks 19.95 × 13.5 × 7.5 cm.

Level 19.90. Bricks 19.90 × 13.5 × 7.5 cm.

Level 19.85. Bricks 19.85 × 13.5 × 7.5 cm.

Level 19.80. Bricks 19.80 × 13.5 × 7.5 cm.

Level 19.75. Bricks 19.75 × 13.5 × 7.5 cm.

Level 19.70. Bricks 19.70 × 13.5 × 7.5 cm.

Level 19.65. Bricks 19.65 × 13.5 × 7.5 cm.

Level 19.60. Bricks 19.60 × 13.5 × 7.5 cm.

Level 19.55. Bricks 19.55 × 13.5 × 7.5 cm.

Level 19.50. Bricks 19.50 × 13.5 × 7.5 cm.

Level 19.45. Bricks 19.45 × 13.5 × 7.5 cm.

Level 19.40. Bricks 19.40 × 13.5 × 7.5 cm.

Level 19.35. Bricks 19.35 × 13.5 × 7.5 cm.

Level 19.30. Bricks 19.30 × 13.5 × 7.5 cm.

Level 19.25. Bricks 19.25 × 13.5 × 7.5 cm.

Level 19.20. Bricks 19.20 × 13.5 × 7.5 cm.

Level 19.15. Bricks 19.15 × 13.5 × 7.5 cm.

Level 19.10. Bricks 19.10 × 13.5 × 7.5 cm.

Level 19.05. Bricks 19.05 × 13.5 × 7.5 cm.

Level 19.00. Bricks 19.00 × 13.5 × 7.5 cm.

Level 18.95. Bricks 18.95 × 13.5 × 7.5 cm.

Level 18.90. Bricks 18.90 × 13.5 × 7.5 cm.

Level 18.85. Bricks 18.85 × 13.5 × 7.5 cm.

Level 18.80. Bricks 18.80 × 13.5 × 7.5 cm.

Level 18.75. Bricks 18.75 × 13.5 × 7.5 cm.

Level 18.70. Bricks 18.70 × 13.5 × 7.5 cm.

Level 18.65. Bricks 18.65 × 13.5 × 7.5 cm.

Level 18.60. Bricks 18.60 × 13.5 × 7.5 cm.

Level 18.55. Bricks 18.55 × 13.5 × 7.5 cm.

Level 18.50. Bricks 18.50 × 13.5 × 7.5 cm.



1



2



3



4



5



6



7



8



9



10



11



12



13



14



15



16



17



18



19

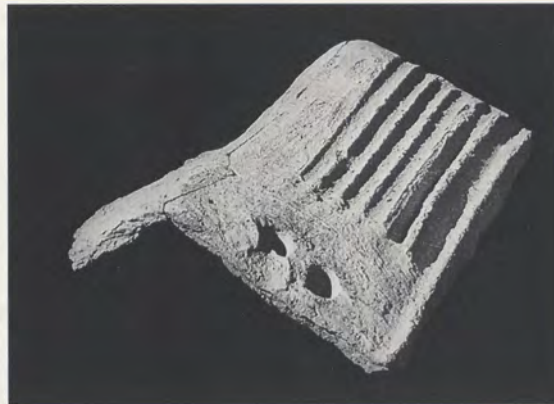

20



21a



21b



22



23



24

N. DECORATED POTTERY

During the excavation all fragments of pottery and loose sherds with decorative designs have been checked and its types registered. Altogether 1294 varying types of patterns were collected. The whole material has been dealt with in a thesis titled "Die Besonderen Scherben von Sonkh", submitted by Dr. Annette Achilles-Bretschneider (Free University Berlin 1980). For the purpose at hand a selection of 186 specimens represents the main types of decorative pottery patterns found in Sonkh. The material is going to be presented Period by Period, thus documenting appearance and disappearance of special methods of decorating potteries, and of the patterns changing so significantly during the times. The different pieces will, within the Periods, be grouped according to their technique in the order *painted, incised, paddle-marked, applied, stamped or moulded*. More complete or intact vessels with decoration are treated in the chapter POTTERY.

Period I. Fragments and Sherds from the PGW-Levels 40 to 37

1. Bowl-fragment of grey ware painted in black on the inner side with rows of dots and traces of strokes crossing the edge. 5.4 × 3.3 cm. So III F 814.
2. Sherd of grey ware painted in black with rows of short strokes on one side. 6.3 × 5.3 cm. So III F 816.
3. Base-fragment of a grey ware bowl painted on the inner side with four sets of strokes meeting at a free square. Black colour getting reddish at the outer ends. Outside reddish. 11.3 × 8.5 cm. So III F 952.
4. Rim-fragment of grey ware painted with a grey and orange horizontal band. 5.7 × 3.5 cm. So III F 821.
5. Rim-fragment of grey ware bowl painted on the inner side with one broad and two narrow vertical strokes, and a border-line along the edge. 3.3 × 3.4 cm. So III F 818.
6. Bowl-fragment of grey ware showing painted rim and set of 10 vertical brush-strokes on the outside. 5.5 × 5.3 cm. So III F 815.
7. Fragment of small bowl of grey ware painted with criss-cross design. 6.3 × 4.7 cm. So III F 827.
8. Bowl-fragment of grey ware painted with groups of curved strokes at the bottom and vertical strokes on the inner side. 10.4 × 7.3 cm. So III F 825.
9. Rim-fragment of grey ware bowl painted with flame-like curved strokes running downwards from rim. 4.1 × 2.6 cm. So III F 823.
10. Sherd of grey ware bowl painted on the inner side with a flower-like design formed by intersecting curved lines. 4.0 × 3.3 cm. So III F 843.
11. Sherd of grey ware bowl painted on the inner side with a set of ash-brown wavy lines of varying thickness. Outside ochre-coloured. 3.8 × 2.6 cm. So III F 960.
12. Sherd of grey ware bowl painted on one side with oblique rows of dots between two parallel lines. 8.3 × 1.5 cm So III F 998.
13. Rim-fragment of grey ware vase painted on the inner side with thick vertical strokes and carelessly placed dots in between. 4.6 × 3.2 cm. So III F 1241.
14. Sherd of grey ware painted with wavy lines and a double row of dots. 5.0 × 4.3 cm. So III F 847.

15. Sherd of grey ware painted with a set of concentric semicircles and parallel rows of dots. 5.8 × 3.8 cm. So III F 826.
16. Base-fragment of grey ware bowl painted on the inner side with strokes and dots and with incomplete concentric circles around bottom centre. 9.9 × 3.9 cm. So III F 836.
17. Base-fragment of grey ware painted with concentric circles and dot in centre. 3.6 × 3.0 cm. So III F 833.
18. Sherd of grey ware bowl painted on the outside with parallel strokes and concentric circles. 7.5 × 5.7 cm. So III F 835.
19. Sherd of grey ware painted with dots in a hook. 3.0 × 2.6 cm. So III F 857.
20. Rim-fragment of grey ware painted with a rim-band and hooked strokes forming a star. 3.3 × 3.1 cm. So III F 1288.
21. Small sherd of grey ware painted with a design in shape of a star. 2.0 × 1.6 cm. So III F 1242.
22. Sherd of grey ware painted with a design formed by hooks emerging from a common centre. 3.6 × 2.2 cm. So III F 1246.
23. Sherd of grey ware painted with a "ladder" and hooks. 7.1 × 6.8 cm. So III F 851.
24. Base-fragment of grey ware painted with two parallel signs shaped like a closed S. 9.3 × 8.9 cm. So III F 1290.
25. Sherd of grey ware painted with a petal-shaped design filled with two rows of short strokes. 5.6 × 4.3 cm. So III F 854.
26. Sherd of grey ware painted with curved strokes, dots, and a corkscrew design. 4.8 × 4.5 cm. So III F 841.

Associated Red Ware

27. Sherd of red ware showing triangles with pecked notches and an incised horizontal herring-bone band as upper border. 11.7 × 10.1 cm. So III F 595.
28. Fragment of red ware vessel incised with a double wavy line along shoulder. 11.6 × 6.3 cm. So III F 994.
29. Fragment of red ware vessel decorated with a horizontal band of an incised design shaped like opened scissor-blades. 6.6 × 5.9 cm. So III F 1280.
30. Shoulder-fragment of red ware vessel decorated with a horizontal band of rows of oblique pecked notches. 11.4 × 5.1 cm. So III F 1279.
31. Rim-fragment of red ware vessel decorated with a horizontal band of oblique short strokes. 12.8 × 6.2 cm. So III F 786.
32. Sherd of red ware decorated with a rough paddle-marked check design. 13.4 × 10.2 cm. So III F 599.
33. Sherd of red ware decorated with a paddle-marked check design. 6.3 × 4.7 cm. So III F 658.
34. Shoulder-fragment of red ware vessel showing a horizontal appliqué rib having oblique incisions. 10.9 × 8.1 cm. So III F 666.

Period II. Fragments and Sherds from Levels 36 to 30

35. Shoulder-fragment of red ware vessel crudely incised with a check design. 5.5 × 4.7 cm. So III F 977. Maurya. L.33/32
36. Rim-fragment of a red ware bowl with incision of an elephant(?) on the inner side. 6.3 × 4.2 cm. So III F 1270. Maurya. L.31/30

37. Base-fragment of NBP ware bowl with stamped concentric circles. 4.1 × 2.9 cm. So III F 1238. Maurya. L.36/35.

38. Base-fragment of grey ware with stamped design of two concentric circles having elevated dots in the outer and a single dot in the central orb. 3.0 × 1.9 cm. So III F 993. Maurya. L.34/33.

Period III. Fragments and Sherds from Levels 28 to 25

39. Shoulder-fragment of red ware vessel showing incised birds and lotus rosettes above geometrical border consisting of incised and punctured grooves. 7.1 × 7.3 cm. So III F 1282. Mitra. L.26/25

40. Shoulder-and-rim-fragment with triangular notches within incised triangles. 10.0 × 4.8 cm. So III F 1219. Mitra. L.27/26

41. Base-fragment of red ware vessel decorated with short notches within incised triangle. 7.2 × 5.5 cm. So III F 619. Mitra. L.25

42. Sherd of red ware decorated with paddle-marked rhomboid design. 7.3 × 7.1 cm. So III F 1284. Early Mitra. L.28

43. Sherd of red ware vessel with paddled parallel grooves. 11.8 × 8.5 cm. So III F 1206. Mitra. L.26

44. Sherd of red ware vessel strongly paddled with sets of parallel grooves. 13.9 × 5.6 cm. So III F 997. Mitra. L.26

45. Sherd of red ware vessel paddled with sets of deep parallel grooves. 8.8 × 8.3 cm. So III F 604. Mitra. L.25

46. Shoulder-fragment of a red ware vessel showing one appliqué and punctured taurine symbol. 4.6 × 4.0 cm. So III F 1285. Early Mitra. L.28(?)

47. Sherd of red ware with appliqué curved svastika on disc-like base. 6.3 × 4.1 cm. So III F 615. Mitra. L.26

48. Sherd of red ware with appliqué curved svastika. 11.4 × 9.9 cm. So III F 988. Mitra. L.26

49. Shoulder-fragment of red ware vessel decorated with an appliqué horizontal rib looking like a twisted cord, and an appliqué nandyāvarta symbol. 10.9 × 10.3 cm. So III F 1143. Mitra. L.26

50. Sherd of red ware vessel decorated with horizontally grooved lines, and a fourfold nandyāvarta impression. 3.8 × 3.2 cm. So III F 1229. Mitra. L.26

51. Sherd of red ware with appliqué nandyāvarta symbol. 9.8 × 6.6 cm. So III F 756. Mitra. Ditch.

52. Shoulder-fragment of red ware vessel showing an appliqué horizontal rib with finger-impressions. 12.7 × 6.6 cm. So III F 877. Mitra. L.27

53. Fragment of a red ware vessel showing two appliqué parallel horizontal ribs with a design of vertical cloth-impressed notches. 8.8 × 7.7 cm. So III F 1220. Mitra. L.27/26

54. Shoulder-fragment of red ware vessel with appliqué horizontal rib looking like a twisted cord. 11.4 × 3.4 cm. So III F 1167. Mitra. L.26

55. Shoulder-fragment of red ware vessel with two appliqué horizontal ribs, one looking like a twisted cord, the other showing thumb-impressed design. 12.7 × 9.2 cm. So III F 1259. Mitra. L.25

Period IV. Fragments and Sherds from Levels 24 to 23

56. Sherd of red ware with a band of zigzag incisions bordered by grooved lines. 4.3 × 5.2 cm. So III F 966. Kṣatrapa. L.24/23

57. Sherd of red ware paddled with sets of parallel grooves. 10.1 × 7.5 cm. So III F 1054. Kṣatrapa. L.24

58. Sherd of red ware with incised and impressed grooves. 14.0 × 4.9 cm. So III F 939. Kṣatrapa. L.24/23

59. Fragment of red ware vessel showing appliqué ribs with notches, and circles with elevated dots. 8.1 × 6.0 cm. So III F 537. Kṣatrapa. L.24

60. Sherd of red ware with moulded double-lined svastika on appliqué disc of clay. 8.1 × 6.0 cm. So III F 887. Kṣatrapa. L.24

61. Sherd of red ware vessel with appliqué angular svastika. 10.4 × 6.2 cm. So III F 1261. Kṣatrapa. L.24/23

62. Sherd of red ware with appliqué lotus rosette. 6.3 × 6.3 cm. So III F 992. Early Kṣatrapa. L.(25)/24

63. Sherd of red ware with impressed nandyāvarta. 4.9 × 4.2 cm. So III F 1266. Kṣatrapa. L.24

64. Shoulder-fragment of a jar in red ware decorated with grooved horizontal lines and stamped semicircles. 10.2 × 5.9 cm. So III F 1189. Kṣatrapa. L.24

65. Shoulder-fragment of a jar in red ware showing two parallel bands of 3-shaped design. 7.6 × 7.8 cm. So III F 1150. Kṣatrapa. L.24

66. Shoulder-fragment of a jar in red ware decorated with horizontal grooves and a band of stamped design shaped like turned S. 5.9 × 4.5 cm. So III F 1217. Kṣatrapa. L.23

67. Shoulder-fragment of a jar in red ware decorated with a horizontal band of impressed svastikas bordered by grooved lines. 12.2 × 5.4 cm. So III F 935. Kṣatrapa. L.23

68. Sherd of red ware decorated with a stamped "star" consisting of elevated dots in between three concentric circles. 5.5 × 3.3 cm. So III F 1169. Kṣatrapa. L.23

69. Sherd of a red ware vessel stamped with star-shaped rosette consisting of triangular petals around two concentric circles. 5.1 × 3.5 cm. So III F 1210. Kṣatrapa. L.23

70. Shoulder-fragment of a jar in red ware stamped with a single oblique leaf-shaped design. A Kṣatrapa speciality. 8.5 × 5.9 cm. So III F 1149. Kṣatrapa. L.24/23

71. Shoulder-fragment of a jar in red ware decorated with a series of a stamped leaf variety. 9.5 × 4.0 cm. So III F 1055. Kṣatrapa. L.24

72. Shoulder-fragment of a jar in red-ware stamped with a vertical leaf. 6.4 × 4.3 cm. So III F 1177. Kṣatrapa. L.23

73. Shoulder-fragment of a jar in red ware decorated with horizontal grooves and a stamped leaf variety. 8.2 × 3.5 cm. So III F 606. Out of context.

74. Shoulder-fragment of a vessel in red ware decorated with a band of impressed triangles (zigzag-line). 9.3 × 5.7 cm. So III F 974. Kṣatrapa. L.23

75. Shoulder-fragment of a red ware vessel showing a double band of impressed triangles (zigzag-lines). 4.5 × 4.2 cm. So III F 990. Kṣatrapa. L.24/23

76. Shoulder-fragment of a red ware vessel decorated with a triple band of impressed triangles (zigzag-lines). 4.6 × 5.3 cm. So III F 1019. Kṣatrapa. L.23

77. Rim-fragment of a red ware vessel decorated with a band of triangles and a stamped leaf. 3.8 × 3.2 cm. So III F 897. Early Kṣātrapa. L.24
78. Rim-fragment of a red ware vessel decorated with a double band of impressed triangles above a band of stamped leaves alternating with stamped lotus rosette. 10.6 × 5.0 cm. So III F 1035. L.25 (out of context?)
79. Shoulder and rim of a jar in red ware decorated with horizontal bands of stamped V-design and curved rows of notches. 17.7 × 12.4 cm. So III F 1276. Kṣātrapa. L.23
80. Shoulder-fragment of a red ware vessel decorated with horizontal grooves as well as stamped arcs, rosettes, and a leaf variety. 6.8 × 5.6 cm. So III F 1118. Kṣātrapa. L.23
81. Shoulder-fragment of a jar in red ware decorated with stamped leaves, nandyāvartas, and sun-symbol with oblique rays. 8.6 × 6.6 cm. So III F 933. Kṣātrapa. L.23
82. Shoulder-fragment of a red ware vessel decorated with horizontal grooves and a stamped design shaped like a vase. At the lower edge remains of a loop. 4.3 × 4.4 cm. Kṣātrapa. L.24
- Period V. Fragments and Sherds from Levels 22 to 16*
83. Shoulder-fragment of a red ware vessel decorated with painted horizontal bands and stamped loops painted over with a gold-coloured wash. 12.0 × 9.0 cm. So III F 300. Kuṣāṇa. L.16/15
84. Sherd of a red ware vessel decorated with an incised band of rhomboid pattern. 5.6 × 5.8 cm. So III F 671. Kuṣāṇa. L.18
85. Fragment of a jar in red ware decorated with an appliqué rib looking like a twisted cord, and an incised and pricked wavy tendril. 10.0 × 5.3 cm. So III F 1002. Kuṣāṇa. L.18
86. Base-fragment of a small red ware bowl with incised triangular “petals” around central circle on the inside. So III F 445. Kuṣāṇa. L.18
87. Sherd of a jar in red ware decorated with an appliqué rib looking like a twisted cord. 12.5 × 6.8 cm. So III F 888. Kuṣāṇa. L.22
88. Sherd of a jar in red ware decorated with an appliqué band showing a row of finger-impressions. 17.4 × 7.9 cm. So III F 247. Kuṣāṇa. L.16
89. Sherd of a jar in red ware decorated with appliqué bands of a design of finger-impressions alternating with a twisted-cord-rib. 11.0 × 6.2 cm. So III F 304. Kuṣāṇa. L.16
90. Sherd of a jar in red ware decorated with grooves and an impressed fish-scale pattern. 13.5 × 11.4 cm. So III F 1131. Kuṣāṇa. L.20/19
91. Rim of a red ware bowl or lamp decorated with appliqué double-crescents. L.4.1 cm. So III F 628. Kuṣāṇa. L.17/16
92. Sherd of a jar in red ware decorated with an appliqué angular svastika showing incised notches. 13.7 × 10.0 cm. So III F 575. Kuṣāṇa. L.19
93. Shoulder-fragment of a red ware jar decorated with a stamped multiple rhomboid design and semicircular creepers. 7.9 × 7.2 cm. So III F 582. Kuṣāṇa. L.22
94. Fragment of a jar in red ware decorated with horizontal grooves, vertical strokes and stamped semicircular garlands. 14.5 × 11.8 cm. So III F 631. Kuṣāṇa. L.21/18
95. Shoulder-fragment of a jar in red ware showing horizontal grooves and stamped V-shaped garlands. 7.0 × 4.9 cm. So III F 363. Kuṣāṇa. L.21/20
96. Sherd of a jar in red ware stamped with a band of crescents (= unclosed circles) and chevrons. 9.2 × 6.8 cm. So III F 557. Kuṣāṇa. L.18
97. Sherd of a red ware jar decorated with stamped double-circles enclosing a dot, and a row of double chevrons. 7.4 × 4.1 cm. So III F 359. Kuṣāṇa. L.18/17
98. Shoulder-fragment of a jar in red ware decorated with horizontal grooves as well as a stamped design of three double circles and semicircular garlands. 6.0 × 4.3 cm. So III F 315. Kuṣāṇa. L.16
99. Shoulder-fragment of a jar in red ware showing two rows of stamped circles with wavy lines in between, and impressed rays and circles below. 15.6 × 7.5 cm. So III F 260. Kuṣāṇa. L.16
100. Shoulder-fragment of a jar in red ware decorated with horizontal rows of dots and circles above fan-like arranged rays hanging down from a horizontal groove. 9.9 × 5.9 cm. So III F 392. Kuṣāṇa. L.16
101. Shoulder-fragment of a jar in red ware with stamped rosettes and the rare design of a flower vase. 10.4 × 6.4 cm. So III F 923. Kuṣāṇa. L.22
102. Sherd of a red ware vessel with a stamped design looking like a vase placed upside down. 5.4 × 4.6 cm. So III F 989. Kuṣāṇa. L.22/21
103. Shoulder-fragment of a jar in red ware decorated with a band of śāṅkhas on grooved ground. 9.6 × 5.1 cm. So III F 896. Kuṣāṇa. L.22/21
104. Sherd of a red ware vessel stamped with a tree-shaped design. 6.2 × 5.3 cm. So III F 434. Kuṣāṇa. L.20
105. Shoulder-fragment of a red ware jar decorated with horizontally grooved lines and a rare floral(?) design. 9.1 × 4.1 cm. So III F 561. Kuṣāṇa. L.19
106. Fragment of shoulder and rim of a red ware vessel richly decorated with horizontal grooves, a band of oblique rows of notches, short strokes and haṃsas between nandyāvartas. 18.0 × 6.1 cm. So III F 1095. Kuṣāṇa. L.21
107. Shoulder-fragment of a jar in red ware decorated with a band of angular svastikas two hooks of which are doubled. 1.9 × 4.8 cm. So III F 621. Kuṣāṇa. L.21
108. Fragment of shoulder and rim of a red ware vessel decorated with stamped rows of 1) svastikas, 2) concentric double circles with dots in centre, and 3) a band of S-shaped design. Below, remains of a horizontal garland. 10.0 × 9.2 cm. So III F 1124. Kuṣāṇa. L.21
109. Shoulder-fragment of a jar in red ware with horizontal grooves and vase-shaped impressions in between. 11.9 × 10.6 cm. So III F 1133. Kuṣāṇa. L.21/20
110. Fragment of shoulder and neck of a red ware vessel decorated with a rib looking like a twisted cord, and a band of stamped vases. 5.6 × 7.5 cm. So III F 642. Kuṣāṇa. L.19
111. Shoulder-fragment of a jar in red ware richly stamped with a band of 1) crossing wavy garlands, 2) flower-bowls(?) placed upside down, and 3) a rib of oblique notches. 11.5 × 5.7 cm. So III F 608. Kuṣāṇa. L.20

112. Fragment of shoulder and neck of a red ware jar decorated with horizontal bands of stamped designs as 1) concentric double circles, 2) a design looking like hands with 6 fingers, and 3) remains of alternating nandyāvartas and rosettes separated by grooved horizontal lines. 10.4 × 5.5 cm. So III F 560. Kuṣāṇa. L.17/16
113. Fragment of shoulder and neck of a red ware vessel richly stamped with horizontal rows of 1) “hands”, 2) rhomboid pattern with central dot, 3) curved sets of short strokes, and 4) long vertical strokes. 11.0 × 14.1 cm. So III F 385. Kuṣāṇa. L.18/17
114. Shoulder-fragment of red ware jar decorated with an appliqué rib looking like a twisted cord and stamped “hands”. 10.1 × 6.8 cm. So III F 527. Kuṣāṇa. L.18
115. Sherd of red ware vessel with stamped śrīvatsa. 7.3 × 6.0 cm. So III F 766. Kuṣāṇa. L.22
116. Shoulder and neck of a jar in red ware stamped with a horizontal band of śrīvatsas. 6.9 × 4.1 cm. So III F 1062. Kuṣāṇa. L.22
117. Sherd of red ware vessel stamped with a śrīvatsa between horizontal grooved lines. 6.6 × 4.5 cm. So III F 762. Kuṣāṇa. L.21/20
118. Shoulder-fragment of a red ware vessel stamped with a rare type of śrīvatsa. 7.1 × 6.8 cm. So III F 764. Kuṣāṇa. L.21
119. Sherd of red ware vessel with stamped śrīvatsa. 3.6 × 3.2 cm. So III F 765. Kuṣāṇa. L.17
120. Sherd of red ware vessel decorated with two rows of notches and a stamped leaf. 9.0 × 7.3 cm. So III F 1115. Kuṣāṇa. L.21
121. Shoulder-fragment of a jar in red ware stamped with a band of different leaves. Below it a nandyāvarta. 9.9 × 5.9 cm. So III F 511. Kuṣāṇa. L.21
122. Shoulder-fragment of a red ware jar stamped with a variation of leaves, a zigzag border and horizontal grooves. 9.0 × 5.6 cm. So III F 1258. Kuṣāṇa. L.21
123. Shoulder-fragment of a red ware vessel decorated with horizontal grooves separating a row of leaf-variations above and a nandyāvarta between S-shaped pattern below. 9.3 × 7.6 cm. So III F 538. Kuṣāṇa. L.21
124. Rim-fragment of a red ware vase decorated with stamped sun-design, leaves, rhomboid patterns, and grooved horizontal lines. H. 7.5 cm. So III F 97. Out of context.
125. Sherd of a red ware vessel with stamped wheel or rosette. 4.9 × 3.2 cm. So III F 865. Kuṣāṇa. L.21/20
126. Shoulder-fragment of a jar in red ware decorated with a rhomboid design as well as “turning wheels” (whirling sun). 7.2 × 4.7 cm. So III F 1192. Kuṣāṇa. L.20
127. Fragment of a jar in red ware decorated with stamped sun-wheels on the shoulder. 9.7 × 9.5 cm. So III F 1128. Kuṣāṇa. L.21/20
128. Sherd of a red ware vessel stamped with “stars”, consisting of rays around two concentric circles with a dot in center. 6.3 × 3.4 cm. So III F 800. Kuṣāṇa. L.18
129. Shoulder-fragment of a vessel in red ware with a horizontal border of impressed triangles and a stamped rosette with elevated dots in the inner circle. 7.9 × 5.3 cm. So III F 513. Early Kuṣāṇa. L.22/21
130. Shoulder-fragment of a vessel in red ware decorated with horizontal grooves with fan-like pendants, and a stamped star-rosette with short rays outside and elevated dots inside the central circle. 12.8 × 9.4 cm. So III F 491. Kuṣāṇa. L.19/18
131. Sherd of a vessel in red ware with a stamped rosette consisting of a wheel with spokes and hub surrounded by seven circles with a dot in center. 8.4 × 6.4 cm. So III F 799. Kuṣāṇa. L.19
132. Shoulder-fragment of a red ware vessel decorated with a semicircle of notches and a stamped rosette with eight petals. 7.7 × 6.3 cm. So III F 534. Kuṣāṇa. L.19
133. Shoulder-fragment of a vessel in red ware decorated with stamped leave-variations and nandyāvarta between horizontally grooved lines. 6.9 × 5.6 cm. So III F 1050. Early Kuṣāṇa. L.22
134. Sherd of a vessel in red ware showing a stamped nandyāvarta. 5.0 × 3.4 cm. So III F 327. Kuṣāṇa. L.20
135. Shoulder-fragment of a red ware vessel decorated with stamped nandyāvartas showing a rather rare flower-like top. 7.5 × 4.8 cm. So III F 1248. Kuṣāṇa. L.21
136. Base-fragment of a small bowl stamped on the inner side with a rosette consisting of a circle with a nandyāvarta in the centre and semicircular leaves on the outer edge. 4.7 × 3.3 cm. So III F 559. Kuṣāṇa. L.17
137. Sherd of a moulded caolin bowl with floral design under a horizontal geometrical border on the outside. 4.6 × 4.3 cm. So III F 522. Kuṣāṇa. L.21
138. Fragment of a moulded caolin bowl relieved with a lotus rosette and other floral ornaments. H. 3.4 cm. Diam. 9.0 cm. So I 22. Kuṣāṇa. L.18
139. Fragment of a moulded red ware vessel decorated on the outside with a circle of rosette leaves, a band with symbols like svastika, cross-flower, vase, flower, and nandyāvarta, each field separated from the other by a vertical double-line enclosing a row of pearls. Below, remains of a band of haṃsas following one after the other. Smooth red slip. 6.8 × 7.0 cm. So I 40. Kuṣāṇa. L.18
140. Fragment of a mould for a small red ware bowl showing a lotus rosette and semicircular loops attached to a horizontal border line. H. 4.7 cm. Diam. 9.5 cm. So III F 810. Kuṣāṇa. L.20
141. Fragment of a small moulded red ware bowl decorated on the outside with a crude type of rosette with triangular petals and leaves. H. 3.5 cm. Diam. 7.0 cm. So III F 468. Kuṣāṇa. L.18
142. Base-fragment of a small moulded bowl in red ware showing on the outside a crude rosette and rows of short ridges. 7.0 × 5.9 cm. So III F 365. Kuṣāṇa. L.18/17
143. Fragment of a small moulded red ware bowl decorated on the outside with a large svastika(?) and a geometrical border. 5.0 × 3.6 cm. So III F 465. Kuṣāṇa. L.18/17
144. Fragment of a small moulded bowl of red ware decorated on the outside with a turning star and an arrow-shaped design above a horizontal rib. 4.1 × 3.5 cm. So III F 464. Kuṣāṇa. L.17
145. Fragment of a small moulded bowl of red ware decorated on the outside with tree-like pattern in a triangle, each separated by a vertical rib. 8.3 × 6.0 cm. So III F 311. Kuṣāṇa. L.16
146. Fragment of a small moulded bowl decorated on the outside with a simple design of twig-shaped ribs. H. 3.2 cm. Diam. ca. 8.0 cm So III F 312. Late Kuṣāṇa. L.16/15

Period VI. Fragments and Sherds from Levels 15 to 12

147. Jar of red ware, red-slipped, decorated with horizontal black painted horizontal stripes. The colour-nuance of the slip is an unmistakably Gupta variant used in combination with the painted black stripes for bowls and jars. So II 822. Gupta. L.16/15
148. Jar of red ware, red slipped, decorated with horizontal black stripes and painted lobed necklace. So II 508. Gupta. L.14
149. Shoulder-fragment of a vessel in red ware scratched with a zigzag-border and a floral(?) design. B. 13.5 cm. So III F 125. Late Gupta. L.14
150. Brown-slipped sherd decorated with scratched triangles alternately filled with zigzag-lines below a zigzag-border within horizontal grooves. B. 14.0 cm. So III F 75. Post-Gupta. L.13
151. Brown-slipped sherd scratched with curved lines and zigzag arranged vertically in nearly parallel rows separated by vertical lines. 10.3 × 8.4 cm. So III F 124. Post-Gupta. L.12
152. Brown-slipped sherd decorated with a scratched bird enclosed by zigzag-borders. H. 13.5 cm. So III F 123. Post-Gupta. L.12
153. Sherd of red ware decorated with a paddle-mark design of rows of elevated dots between bordering ribs. Mica-washed. 9.9 × 7.6 cm. So III F 273. Post-Gupta. L.12
154. Sherd of a red ware vessel paddled with a design of dots between parallel ribs. Traces of mica. 5.8 × 5.8 cm. So III F 201. Post-Gupta. L.13/12
155. Sherd of a red ware vessel paddled with a design of dots in rhomboid fields. Covered with mica. 5.9 × 4.7 cm. So III F 198. Post-Gupta. L.13/12
156. Sherd of a red ware vessel decorated with appliqué pointed elevated dots. Painted over with mica. 6.2 × 5.2 cm. So III F 188. Post-Gupta. L.13/12
157. Sherd of red ware decorated in relief with fish-scale pattern. Covered with mica. 12.5 × 6.2 cm. So III F 183. Post-Gupta/Early Medieval. L.12
158. Sherd of red ware decorated in relief with a floral design. Traces of mica. B. 8.8 cm. So III F 96. Post-Gupta/Early Medieval. L.12
159. Fragment of a red ware vessel decorated with a complicated moulded design of elevated dots, circles, ribs and curved lines. Painted over in red, black, and gold. 10.0 × 7.5 cm. So III F 341. Gupta. L.16/15
160. Fragment of a moulded red ware vessel with elevated curved lines. Painted over in olive and red-brown. 4.3 × 3.5 cm. So III F 342. Gupta. L.16/15
161. Fragment of a moulded red ware bowl with a design of two concentric circles enclosing an elevated dot. 9.5 × 7.5 cm. So III F 343. Gupta. L.16/15
162. Fragment of a small moulded red ware bowl decorated with stylized petals and a horizontal rim-line. 5.5 × 5.8 cm. So III F 147. Post-Gupta. L.13/12
163. Fragment of a small moulded red ware bowl with a design of vertical ribs. 4.0 × 6.3 cm. So III F 144. Post-Gupta. L.13/12
164. Fragment of a small moulded bowl in red ware covered with a rhomboid lattice design. 4.0 × 7.2 cm. So III F 239. Post-Gupta/Early Medieval. L.12/11

165. Fragment of a moulded red ware bowl decorated with symbols. 5.2 × 12.8 cm. So III F 288. Post-Gupta. L.12

166. Fragment of a moulded red ware bowl with a lotus rosette and wave bands. 5.0 × 6.4 cm. So III F 141. Post-Gupta/Early Medieval. L.12/11

167. Fragment of a moulded red ware bowl with a rosette within a geometrical setting of lines. 4.5 × 5.8 cm. So III F 152. Post-Gupta. L.12

168. Fragment of a moulded red ware bowl decorated with two lotus rosettes one above the other in sectors separated by vertical double-ribs. Along the bottom a horizontal line of elevated dots (pearl-border). 7.0 × 13.7 cm. So III F 134. Post-Gupta. L.12

169. Fragment of a moulded red ware bowl decorated with a lotus-rosette in separate sectors. 8.0 × 6.6 cm. So III F 277. Post-Gupta. L.13/12

170. Small fragment of a moulded red ware bowl with śaṅkhas in separate sectors. 4.8 × 4.8 cm. So III F 85. Post-Gupta/Early Medieval. L.12/11

171. Sherd of a moulded red ware vessel decorated with a complicated design of floral and geometrical pattern. 7.0 × 4.8 cm. So III F 177. Post-Gupta. L.12

172. Sherd of a moulded red ware vessel decorated with a complicated labyrinth design of elevated lines. 6.2 × 6.0 cm. So III F 156. Post-Gupta. L.12

173. Shoulder-fragment of a moulded red ware vessel decorated with two bands of animals one behind the other, separated by horizontal ribs. 9.1 × 4.9 cm. So III F 200. Post-Gupta/Early Medieval. L.12/11

Period VII/VIII. Fragments and Sherds from Levels 12 to 1

174. Fragment of a big jar, red-slipped, decorated with black painted horizontal stripes, oblique lozenges, zigzag-line, delicately painted swans, a lobed necklace, and dots on the rim. So II 849. Post-Gupta/Early Medieval. L.13/12

175. Fragment of thin grey ware, white slipped, decorated with incised and painted floral and geometrical pattern in olive colour. 10.9 × 7.9 cm. So III F 61. Late Medieval/Early Islamic. L.10

176. Fragment of thin grey ware, white slipped, decorated with incised and painted floral pattern in olive colour. 8.7 × 5.8 cm. So III F 62. Late Medieval/Early Islamic. L.10

177. Sherd of a red ware vessel, red polished on the outside, painted with silvery rays. 4.0 × 3.2 cm. So III F 167. Islamic. L.7

178. Globular jar, red-slipped, decorated with black and white painted ornaments. So II 3081. Jāt. L.4

179. Carinated jar, red-slipped, with black painted decoration. So II 233. Jāt. L.4

180. Shoulder-fragment of a red ware vessel decorated with groups of incised lines arranged in a zigzag-design between bands of horizontal grooves. 7.8 × 4.3 cm. So III F 114. Islamic. L.7/6

181. Sherd of thin red ware decorated with scratched leaves on white slipped ground. 5.7 × 4.9 cm. So III F 504. Jāt. L.4

182. Rim-fragment of an egg-coloured red ware bowl decorated with a scratched fish-scale pattern below parallel lines. 2.5 × 2.5 cm. Jāt. L.4

183. Sherd of a black-slipped vessel decorated with stamped stars and circles between horizontal grooves. 4.9 × 5.1 cm. So III F 24. Jāt. L.5

184. Sherd of a moulded yellow-brown vessel decorated with a floral design and a row of circles filled with dots. 5.0 × 5.0 cm. So III F 52. Islamic. L.9

185. Sherd of soft light brown, white slipped moulded vessel, on the outside with rows of floral design bordered with a pearl-band. 5.4 × 4.4 cm. So III F 34. Islamic. L.8/7

186. Fragment of a soft light brown moulded vessel, on the outside with large circles and star design surrounded by geometrical patterns. 7.4 × 4.9 cm. So III F 32. Islamic. L.8/7

O. POTTER'S STAMPS

The excavation yielded twentytwo terracotta objects which are undoubtedly potter's stamps or fragments of such. Sixteen of them come from Kuṣāṇa levels, four are surface finds but can be allotted to the Kuṣāṇa period, two pieces have been found in Gupta levels. One of these objects is not a stamp but a potter's mould for the decoration of small bowls. With the exception of five unproductive fragments the seventeen remaining specimens are listed here.

Periods V/(VI). Potter's Stamps from Levels 20 to (13)

1. Double-faced stamp with 1) a large semicircular design consisting of a row of holes and, above it, a band of vertical strokes, and 2) a small round rosette formed of the same patterns as contained in no. 1.

Diam. 6.1/3.1 cm. So III A 17. Kuṣāṇa. L.18

2. Double-faced stamp with 1) a semicircle of vertical notches and 2) a small circle impressed with notches.

Diam. 6.0/3.3 cm. So III A 939. Kuṣāṇa. L.18

3. Stamp with conical handle showing a slightly mutilated nandyāvarta symbol.

L. 4.8 cm. So III A 1851. Kuṣāṇa. L.20

4. Stamp with perforated conical handle showing a nandyāvarta symbol different from no. 3.

L. 4.5 cm. H. 2.6 cm. So III A 1700. Kuṣāṇa. L.20

5. Stamp with conical handle deeply carved with a nandyāvarta symbol of the spiral type.

L. 4.3 cm. H. 2.8 cm. So III A 135. Kuṣāṇa (out of context).

6. Stamp with stubby rounded handle carved with a nandyāvarta symbol of the leaf type.

L. 3.7 cm. H. 2.5 cm. So III A 687. Kuṣāṇa. L.16

7. Stamp with conical handle carved with a nandyāvarta symbol of cracknel type.

L. 3.6 cm. H. 2.0 cm. So I 34. Kuṣāṇa (out of context).

8. Stamp with tapering handle carved with a rosette of pointed leaves. L. 6.5 cm. Diam. 4.2 cm. So III A 1142. Kuṣāṇa. L.17

9. Double-faced stamp with tapering handle carved with 1) a larger rosette consisting of two concentric circles surrounded by smaller circles, and 2) a smaller but similar rosette as 1).

L. 3.8 cm. Diam. 2.9 cm. So III A 1106. Kuṣāṇa. L.20

10. Stamp with tapering handle carved with a design similar to no. 9 but of cruder make.

L.3.8 cm Diam. 3.6 cm. So III A 828. Kuṣāṇa. L.16

11. Stamp with a pedestal-shaped handle bearing rosette design in the centre surrounded with a band of vertical strokes.

L.4.5 cm. Ø 3.9 cm. So III A 114. Kuṣāṇa (out of context).

12. Stamp with a stepwise tapering handle bearing rosette design in the centre surrounded with two bands of ray-like strokes.

3.9 × 6.2 cm. So III A 15. Kuṣāṇa (out of context).

13. Mutilated stamp with tapering handle bearing a "geometrical" rosette with a spiral in the centre and with a surrounding band of tripartite "rays" intended to continue the inner lines. The design gives the impression of movement.

H. 3.7 cm. Diam. 5.7 cm. So III A 902.

Found in Late Gupta L.14/13

14. Small pottery stamp with sharply cut rosette having triangular leaves surrounding two concentric circles forming the slightly deepened centre.

H. 1.5 cm. Diam. 2.0 cm. So III A 685. Kuṣāṇa. L.17

15. Fragment of a stamp with the carved design of seven concentric circles.

H. 2.2 cm. Ø 9.8 cm. So III A 1277. Kuṣāṇa. L.19

16. Stamp with long tapering handle carved with a spiral ending in a hole in the centre.

H. 5.1 cm. Diam. 3.1 cm. So III F 824.

Found in Late Gupta L.14

17. Potter's mould for the decoration of a small bowl with a design of a rosette having punctured leaves, meant for producing elevated dots.

Diam. 7.9 cm. So III A 2050. Kuṣāṇa. L.17

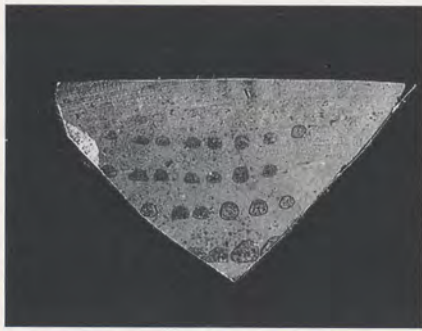

1

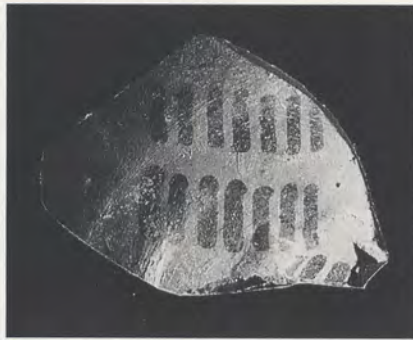

2



3

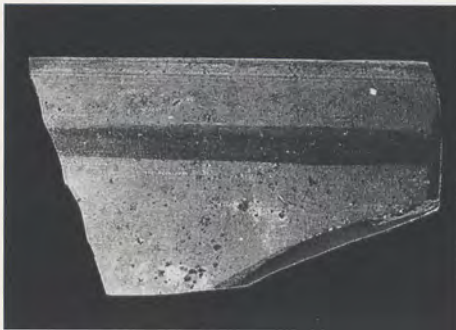

4



5

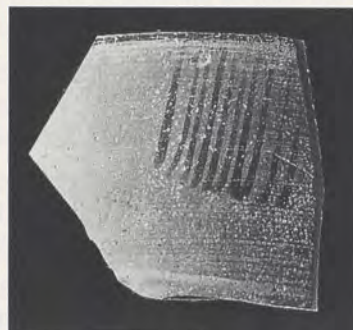

6



7



8

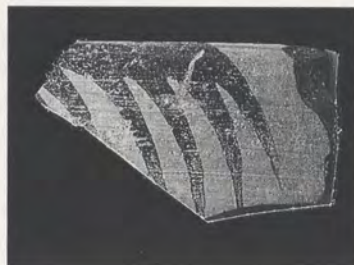

9



10



11



12

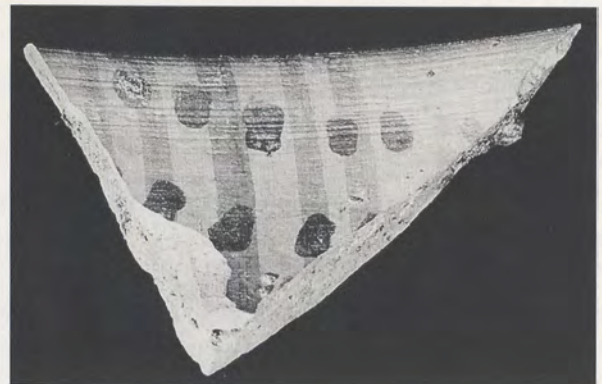

13

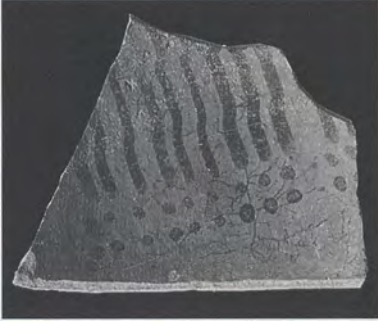

14



15



16

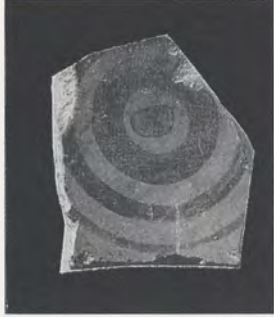

17



18

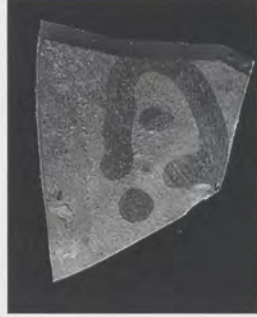

19



20



21



22



23

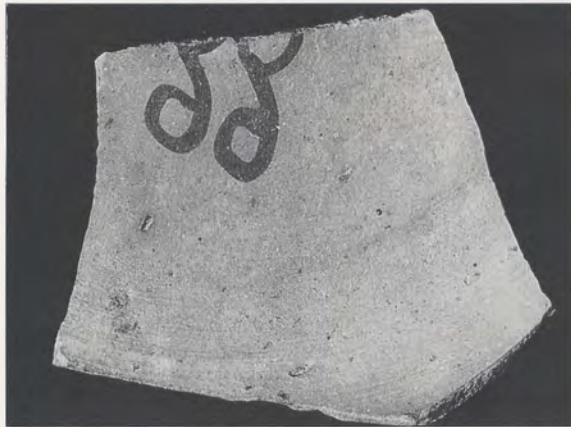

24



25



26



27



28

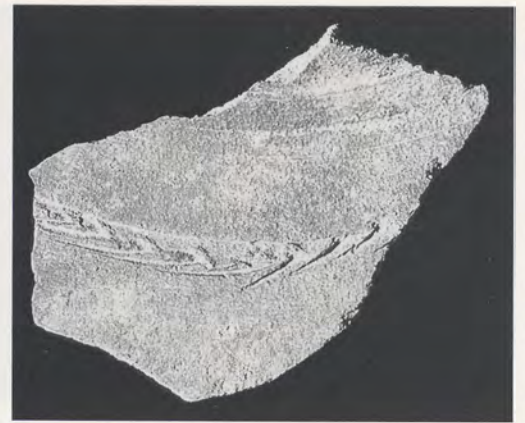

29

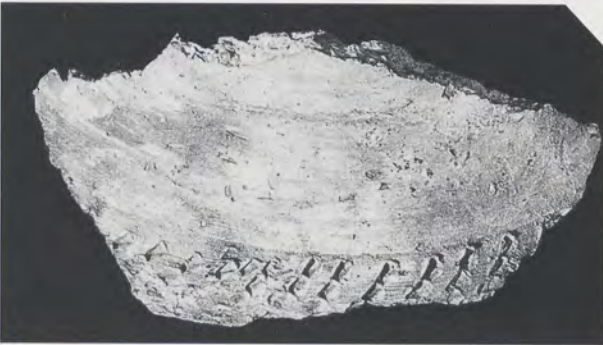

30



31



33



32



34



35



36



37



38

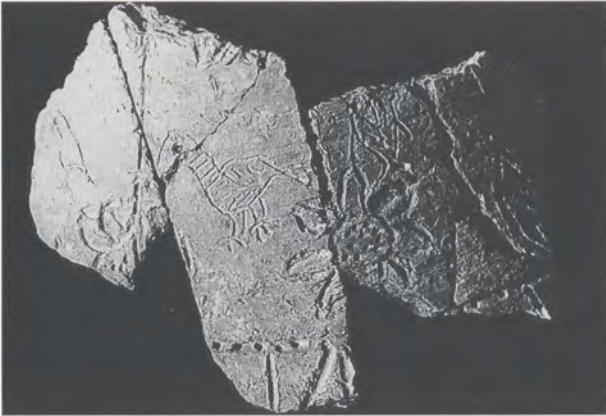

39



40



41



42



43



44



45



46

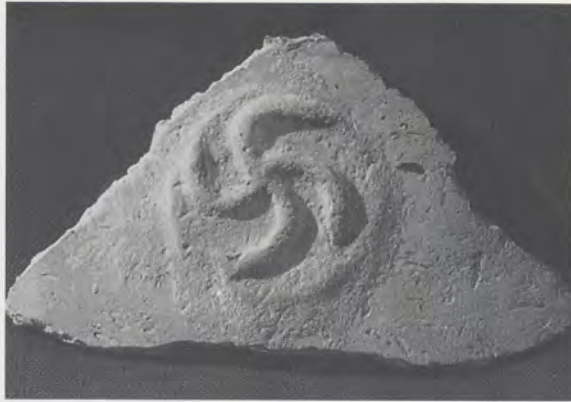

47



48



49



50



51



52



53



54



55



56

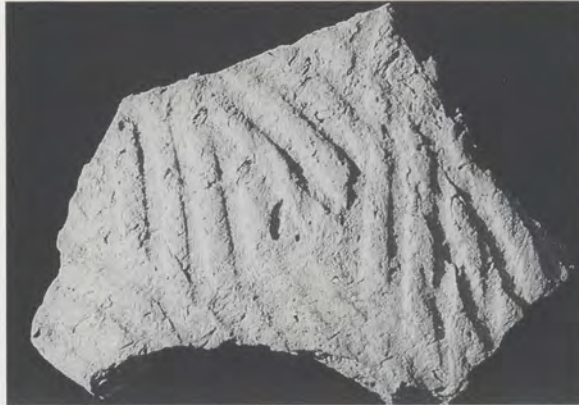

57



58



59



60



62



61

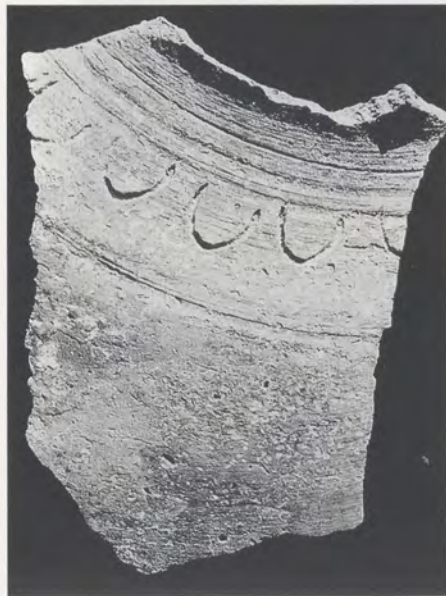

64



63



65

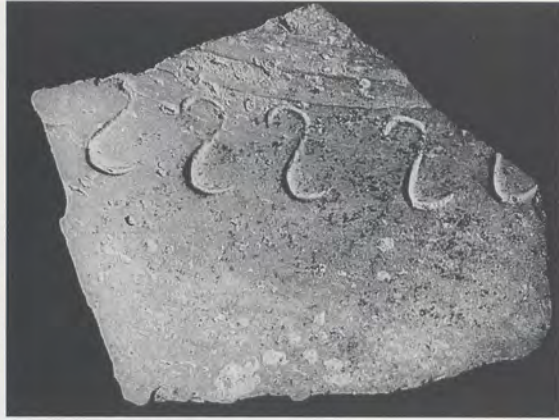

66



67



68



69



70



71



72



73



74



75



76



77



78



79



80



81



82



83



84



85



86



87

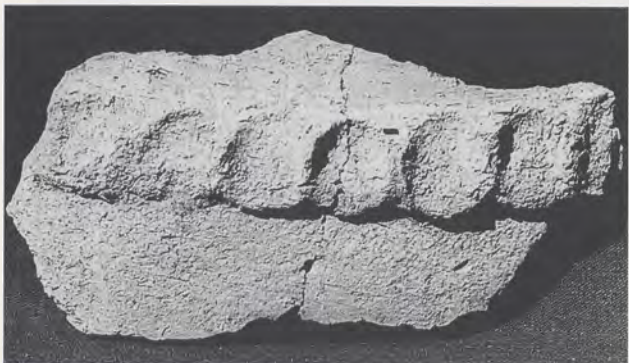

88



89



90



91



92



93



94



95



96



97



98



99



100



101



102



103

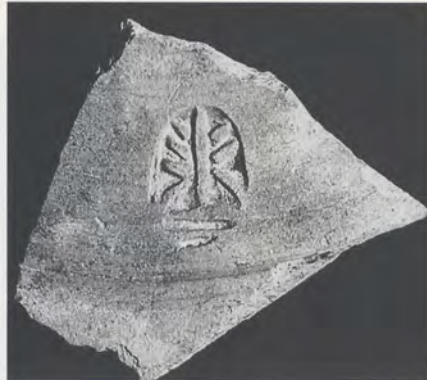

104



105



106



107



108



109



110



111



112



113



114



115

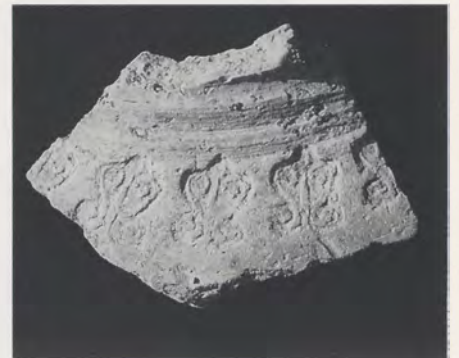

116



117



118



119



120



121



122



123



124



125



126



127



128



129



130



131



132



133



134

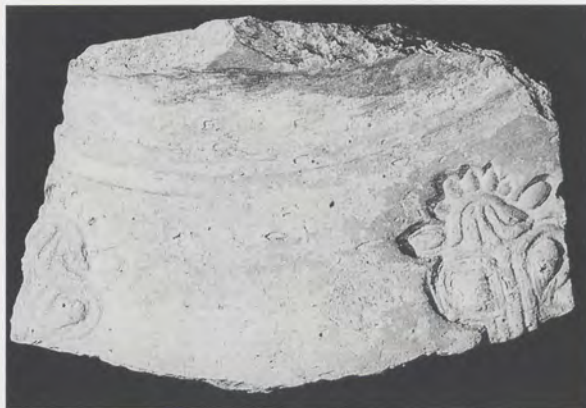

135



136



137



138



139



140



141



142



143



144



145



146



147



148



149

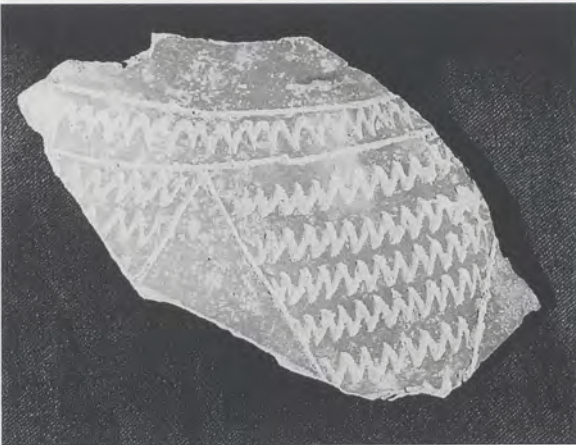

150

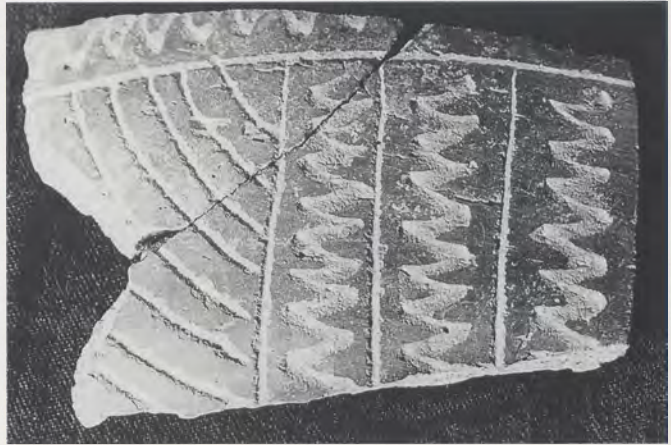

151



152



153



154

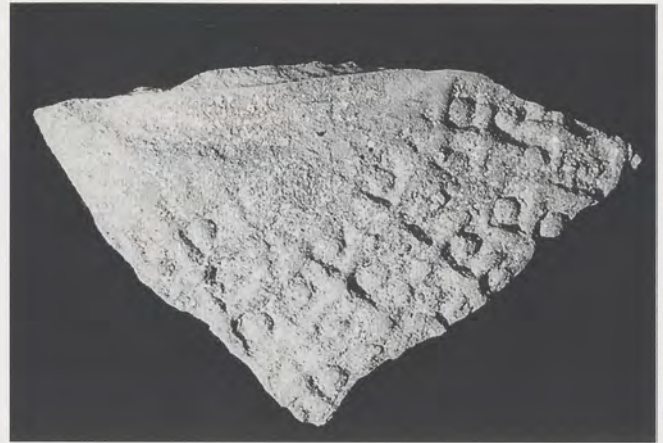

155

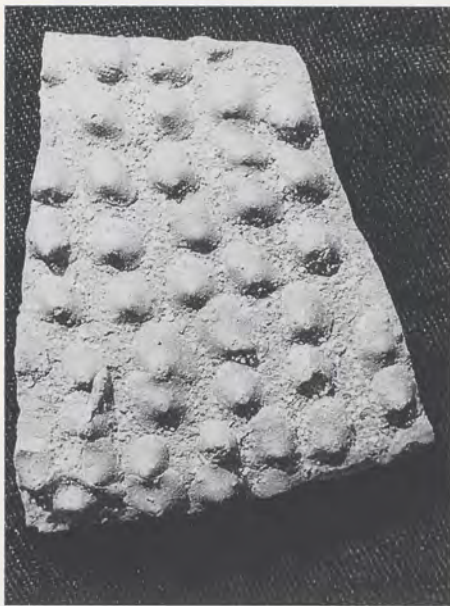

156



157



158



159



160



161



162



163



164



165



166



167



168



169



170



171



172



173



174

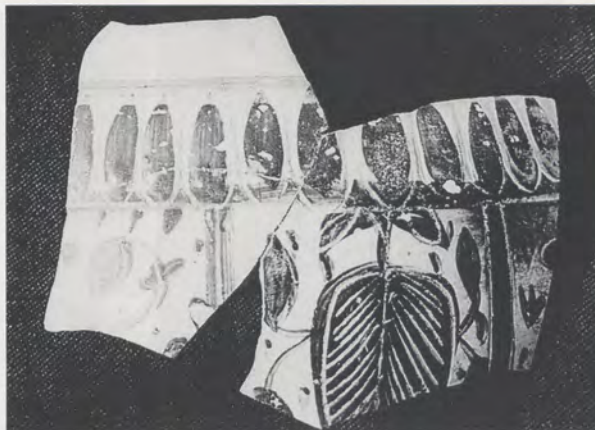

175



176

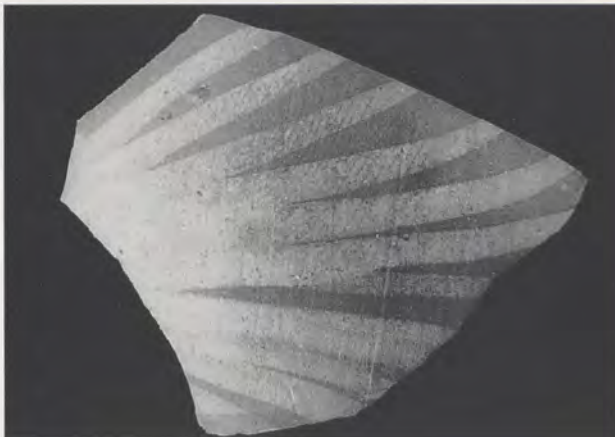

177



178

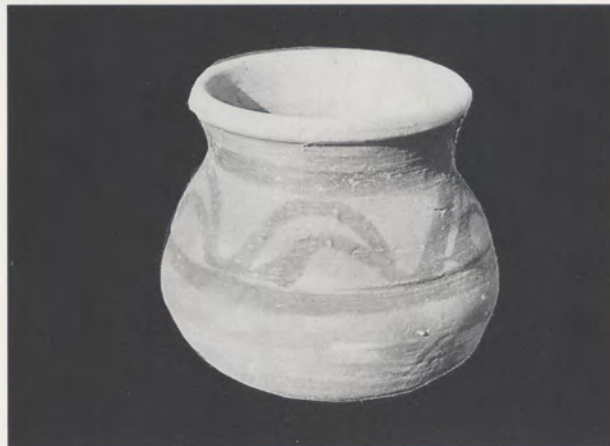

179



180



181



182



183



184



185



186



1a



1b



3



2a



2b



4



5



6



7

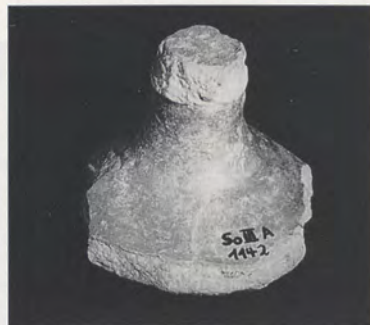

8a



8b



9a



10a



11a



9b



10b



11b



12



13



14



15



16



17

P. POTTERY

Introduction

The excavation registers 3120 pots and shape-retaining pottery fragments. The majority of them has been found in their original surroundings and in datable context. This report intends to sum up the main types and shapes of the pottery from Sonkh through all the Periods. A simultaneous study of the material published in the chapter DECORATED POTTERY will be helpful.

The pottery assemblage at Sonkh comprises in the main groups the following wares:

Period I	Painted Grey Ware, Black-and-Red Ware, Associated Grey and Red Wares
Period II	Northern Black Polished Ware, Associated Grey and Red Wares
Period III–VI	Red Wares with increasing modes of decoration
Period VII–VIII	Red and thin Grey Wares with growing Islamic component

In general the pottery of Sonkh is strongly related to that of other sites between western Rajasthan and central Uttar Pradesh, Punjab and northern Madhya Pradesh, like Rang Mahal, Kaushambi, Hastinapura, Ahicchatra, Atrañjikhera and others.

Period I: The Pottery from the Painted Grey Ware-Levels

In the area of Sonkh, Painted Grey Ware Pottery (PGW) occurs simultaneously with the Black and Red Ware (BRW), with which it has in common the thin wall and base and the burnished surface. The typical PGW has a grey core of very fine clay texture and is decorated with comb-painted geometric, abstract and symbolic ornaments (see DEC.POT. nos. 1–26), swiftly flung on the outer and inner surface in black or dark grey colour, or even in brownish and greenish shades. With this ware, dishes with convex bottom and carinated or incurved walls are conspicuous (nos. I.1, 2) accompanied by hemispherical bowls (Fig.81) and cups with steep walls (no. I.33) as the main shapes.

BRW consists, like PGW, of more or less hemispherical bowls (Fig.82), tulip bowls (no. I.26) and other types of beakers. The Sonkh specimens of this ware carry no ornaments.

Some of the PGW and BRW vessels seem to be made on the potter's wheel, but others are made by moulding the base and building up the wall on a turntable. The wheel-thrown pots have either turned or beaten bases.

Besides the fine grey and painted specimens there occurs a grey ware of cruder fabric and with an increased thickness of the wall. These types are wheel-thrown with roughly beaten or scraped bases. The bowls, dishes, cups and jars of this grey ware are occasionally covered with a black slip. In a few cases the bottom shows, on the inside, stamped rosette ornaments.

Associated with the rather delicate PGW and BRW potteries are storage jars (no. I.40), water jars (Fig. 83), bowls, jarlets and cauldrons of less refined clay and texture, of brick-red colour, either wheel-thrown or, definitely in the case of the storage jars, coiled and beaten, sometimes even showing ribbed paddle-marks. The water jars of this period are, in general, globular with concave necks and out-curving rims, in a few cases stamiped with a taurine symbol or separate circle and semicircle, inside the rim (no. I.53). Some vessels of the associated ware are embellished with incised or impressed lines, or band, or with applied cordons.



81 Painted Grey Ware bowl



82 Black-and-Red Ware bowl



83 Red ware jar of PGW Period

Period II: The Northern Black Polished Ware and the Mauryan Red Wares

The PGW, BRW and its contemporary associated wares were, to our knowledge, the earliest pottery products of the Mathura region. With the next phase the Mauryan period opens and with it, the traditions of PGW and BRW terminate. The Coarse Grey Ware seems to become more frequent; the fashion of black-slipping increases in such a way that even grey terracotta figurines get slipped.

Beginning with the Maurya period, the Northern Black Polished Ware (NBPW) makes its appearance. At Sonkh, quite a number of mostly very small sherds have been found. From rims, the shape of the vessels can at least be partially reconstructed. All available sherds belong to shallow bowls and dishes, most of them rather large, with flat or convex bottom and angular, nearly straight, inclined wall and plain rim, which obviously retain elements of PGW. The paste is of very fine fabric and of grey, buff or reddish colour. A typical feature is the thin light red or pink layer beneath the coating. The coating itself is black, dark steel-blue, or dark brown. It is lustrous and iridescent. Considering the extreme thinness of the sherds in relation to the size of the dishes one can rightfully call this ware the luxury porcelain of the Mauryas.

On the whole, red ware becomes more dominant during the 4th and 3rd centuries BC. Storage jars are of the same manufacture and they retain the previous shapes. Pyriform or gourd-shaped water jars appear along with globular ones. The typical pyriform jar has a rather wide carinated neck (no. II.23; Fig. 84). Cooking vessels with lenticular base, bulging or carinated wall and angular everted rim appear in early Mauryan times. The bottom of these vessels contains mica in minute particles, obviously in order to make the vessels fireproof. In one case, a taurine symbol is impressed on the exterior of a cooking bowl. Slurry-daubing seems to appear for the first time.

Some rather peculiar types of small bowls or dishes are worth mentioning here. They have inward beaded or bevelled rims and they can be grey, black-slipped grey, or red. Another type of the 3rd century BC is a carinated dish with slightly convex base and everted or flaring rim, the base containing mica (no. II.71). This type can be traced up to the 2nd century AD. Globular ointment jarlets continue from PGW times, in red ware. A rather large lid in the shape of a curved dish with central loop-handle belongs here also (no. II.89).

Two objects found in the Mauryan levels at Sonkh may point to the existence of animal-shaped and figuratively adorned vessels in the 3rd century BC. A rather peculiar-looking object, for instance, is the fragment of a tortoise-shaped vessel (no. II.62). It is of red clay, the trunk seems to be wheel-thrown with presumably six leg or neck-appendages. The surface is red-slipped and decorated with incised grooves. It may have been used as a lamp. A small female terracotta head of brown colour originates from late Mauryan times (HUMAN TERR. FIG. no. 15). At the point of fracture throwing marks are visible. The head had presumably been attached to the neck and shoulder of a pot, comparable to a complete vessel in the reserve collection of the Mathura Museum.

The Pottery of the Śuṅga Cultural Phase

In the 2nd century BC the style of the pottery did not undergo sudden changes. As for storage jars, there is hardly any evidence of their shape. A single fragment of a rim suggests the continuation of the old types. Many of the pyriform water jars, which already appeared in Maurya times, are now decorated with ribbed paddle-marks (no. II.92; Fig. 85).

Cooking vessels with carinated wall become dominant (no. II.87). Worth mentioning are small thick-walled jars with or without criss-cross pattern on their shoulder and perforations in the neck (no. II.86). Another typical sample is the "jar-cum-bowl", that

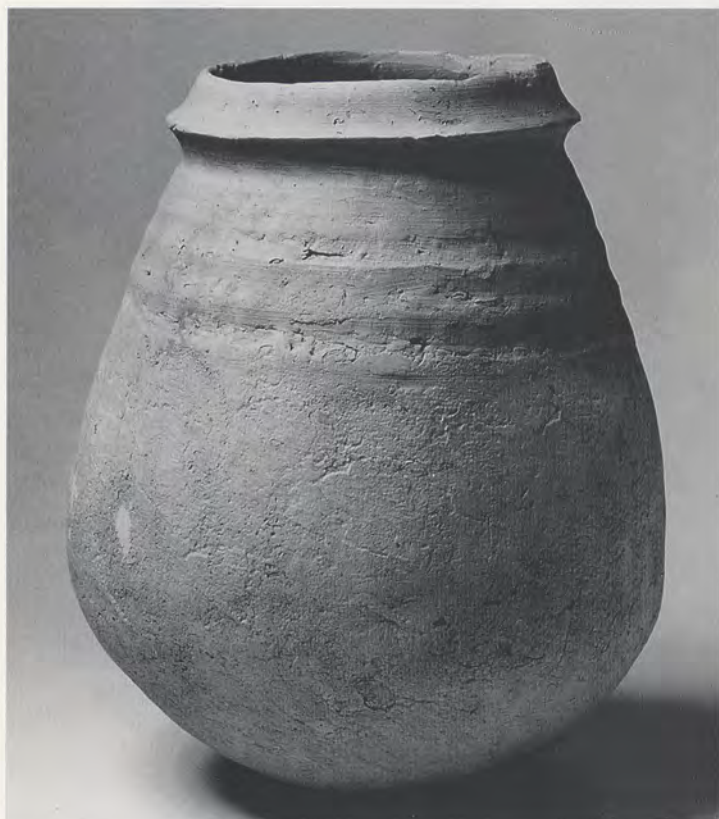

84 Red ware pyriform jar, Period II

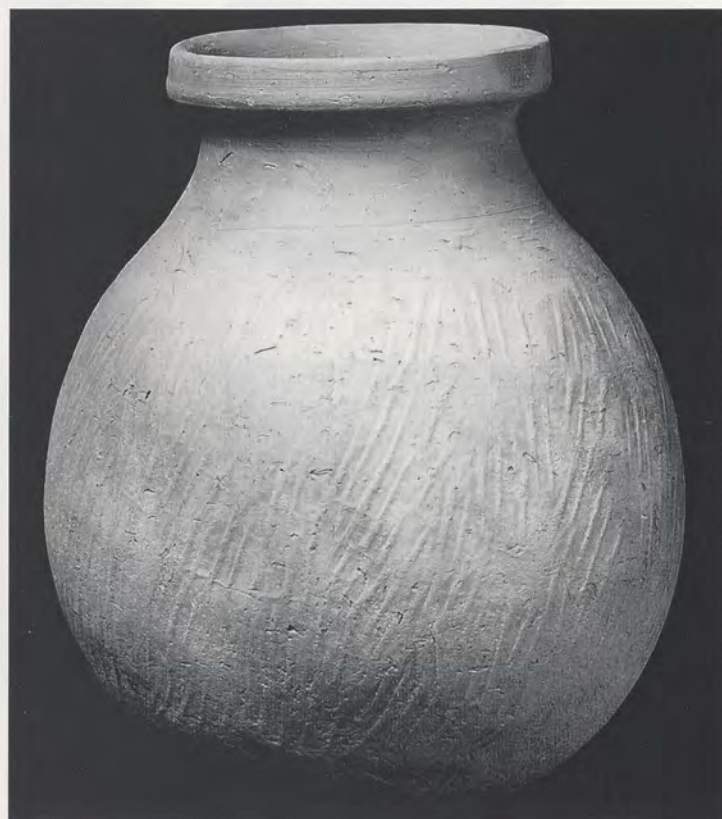

85 Pyriform jar with paddle-marks, Period II

means the lid is in the shape of a small jar or beaker with a slanting flange (no. II.88). In the same levels one again finds the slightly concave lid with central loop-handle.

The NBP Ware terminates; the black-slipped Grey Ware survives in the form of bowls with in-beaded rims, or large bowls with faceted rims, also jars with funnel neck (no. II.79). But the shallow grey bowl with convex bottom and nearly straight wall is replaced by the funnel-bowl with narrow untreated flat base and up-curved or inflected, later on also carinated, rim of red ware (no. II.42ff.). This type of bowl appears in ever increasing quantity up to the Kuṣāṇa age and later. Its frequency as the typical food bowl causes one to call it “common bowl”.

A great variety of small vases and jars with flat bases develops. Jars with bow-rims are peculiar to this period (no. II.98). A small globular ewer with flat base and narrow neck, unfortunately having the rim missing, is the oldest spouted vessel so far known in this region (no. II.59).

Period III: The Pottery in the Time of the Mitras of Mathura

With Gomitra, the period of the Mathura rulers with -mitra ending names begins. In their time, that is from the end of the 2nd century to the second half of the 1st century BC, many pottery types continue: as for instance the oblong storage jar without decoration, the pyriform jar with or without paddle-marks, the common bowl, the jar-shaped lid and the carinated cooking vessel. Others, like the jar with bow-rim, the cooking vessel without carination, the slightly concave lid with central loop-handle, and above all, the Coarse Grey and black-slipped Grey Wares *do not survive*.

New are a storage jar, elliptical in section (no. III.17), a big oblong but neckless jar with crudely incised vertical strokes (no. III.18) and ovoidal storage jars with appliqué cordons and symbols (svastika, nandiyāvarta and lotus rosette) (no. III.16; Fig. 86). Simpler forms of the taurine, nandiyāvarta and svastika symbols occur on a number of sherds from the Mitra levels at Sonkh (see Dec.Pot., nos. 46–49). In this connection a water jar with incised svastika and nandiyāvarta (no. III.5) is to be mentioned. The pyriform jar now often shows a gently upward curving long neck (no. III.11). New are also a bottle with an apple-shaped trunk and a slender deeply profiled double-carinated neck (no. III.59), and a bottle with a hemispherical trunk, a conical shoulder and a corrugated neck (no. III.58; Fig. 87). A small waisted jar with flat or convex bottom and funnel-rim is noticeable (no. III.71). Furthermore there are the barrel-jar with grooves (no. III.19), the bowl or dish with “eared” loop-handles (no. III.39), another one with “eared” spout, and a small cup-shaped libation vessel with long spout (no. III.110).

Two fragments of a bowl and a jar deserve special attention because of their peculiar spouts, which are chevron-shaped and pointing downwards (nos. III.69; 99). The bowl seems to have been standing on legs or stilts. Another interesting pottery item of this Period III is a fragment of a vessel showing a handle in the shape of a monkey with upturned tail (see Misc.Terr.Obj.,no. 6).

Period IV: The Pottery in the Time of the Dattas and Kṣatrapas of Mathura

The time from the last quarter of the first century BC to the middle of the first century AD is characterized by definite stylistic differences in the pottery products from the foregoing period. Storage jars develop the shape of the Mitra vessels or are of a new type, the distinctive features being a short neck and beaded, sometimes even undercut, rim (no. IV.25). Conspicuous are globular water



86 Storage jar with appliqué cordons and symbols, Period III

jars and ewers with corrugated necks or rims (no. IV.5). In this period, or more precisely in the latest phase of Kṣatrapa structures at Sonkh, the fashion of *stamping* the vessels with a rosette, nandiyāvarta or other designs begins.

Among the small vessels, a bell-shaped cup with clearly protruding foot (no. IV.42) shows affinities with Central Asian and Bactrian goblets in clay or metal of the same era. It is comparable also to a Kṣatrapa metal goblet from Level 23 at Sonkh (see chapter METAL, no. 58). Other new shapes are a capstan-shaped cup with saggar base (no. IV.38; Fig. 88), a beaker with bulging wall and grooved vertical rim (no. IV.41; Fig. 89), a small double-carinated jar appearing in great quantity (no. IV.17), a bowl lid with

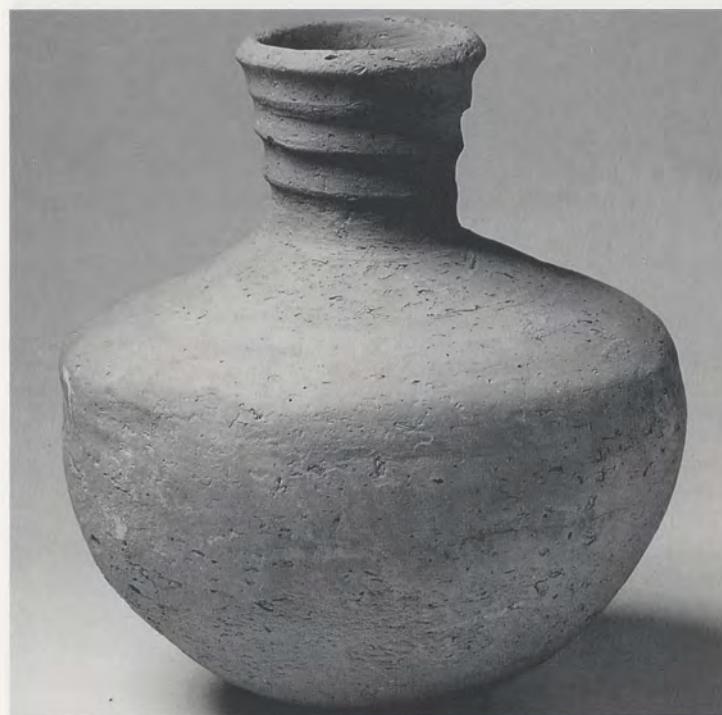

87 Bottle with corrugated neck, Period III



88 Cup with saggar base, Period IV



89 Beaker with grooved vertical rim, Period IV

central grip-hole (no. IV.53), and an elegant globular bottle with a slightly bulbous long neck and smooth red slip (no. IV.1). The small spouted libation vessel turns up again, but this time with double-spout and fish-tail handle (no. IV.59).

Period V: The Pottery of the Kuṣāṇa Era

In the Kuṣāṇa era a number of shapes of the preceding levels show further development and in addition, quite a number of new types appear. The most characteristic feature of the pottery in this period is the abundant *stamping* of storage vessels, jars and ewers with symbolic, floral or geometric ornaments (Fig. 90). Many different forms such as śrīvatsa, nandyāvarta, cakra, svastika, haṃsa, rosette, leaf, circle and combinations of them turn up as decorative patterns (see chapter Decorated Pottery). Besides the stamped designs the first ornamentally moulded small bowls (nos. V.82 ff.), jars or ewers have been found. They are met with in

the middle Kuṣāṇa levels, the specimens being rather crudely executed, showing lotus and other ornaments on the exterior of bowls (Fig. 91), but in time, the ornaments rise to a high standard of craftsmanship, culmination in vessels from the end of the Kuṣāṇa to the Gupta period (see Dec.Pot., no. 139).

The globular water jars with corrugated rim or neck are now very often spouted (no. V.20), the spout sometimes being shaped as a makara's or a horse's, bull's or bird's head. The smooth ovoidal bottles with long neck continue, and additionally there appear bottles with the sprinkler neck, well known from other parts of



90 Storage jar, stamped with floral ornaments. Period V



91 Small moulded bowl with ornaments on the exterior. Period V

northern, central and western India (no. V.1). Rather outside the usual style or styles of the Kuṣāṇa potteries from Sonkh is a saddle-shouldered, narrow-necked ewer with a steep and long tapering spout, a flaring rim and a loop-handle (no. V.6).

Although there are still bowl-lids with central grip-hole, the majority are now bowl-lids with central knob and a distinct flange (no. V.87 ff.).

Period VI: The Pottery of the Gupta and Post-Gupta Levels

These levels show a ware with characteristics rather distinguished from that of earlier levels, as it is much more delicately thrown, has a smooth, mostly red slipped surface very often painted with distinct black horizontal stripes (nos. VI.8 ff.; Fig. 92) arranged in bands of three or two stripes, later on replaced by painted swans and floral ornaments (no. VI.30). The necks of the jars are sometimes double-rimmed (nos. VI.15 f.) or deeply channelled. Some of the jars have spouts with pointed crops. The shapes of the trunks vary from heart-shape to oblate globular, several with saddle-shoulder. The latter can be decorated with raised dots and ridges, partially coated with mica or gold-coloured slip. The body is of medium chaff-tempered fabric, with grey-black core.

There are also bowls with bulging walls and flaring rims. Small moulded bowls with relief ornaments continue, but now they are much more refined. A goblet with moulded bowl and stem is remarkable (no. VI.78; Fig. 93). Some of the bottles with bulging trunk have sprinkler necks and spouts. The cooking vessels don't differ so much in shape from those of earlier levels. The funnel-bowls are now mostly with plain straight rim instead of stepped in-curved or carinated ones. Besides bowl-lids with central knob, bell-shaped lids with grooved or painted decoration turn up. A special feature of this period are the elaborately made pedestal lamps with loop-handle and scalloped rim.

Periods VII/VIII: The Pottery of the Medieval and Islamic Levels

Above Level 12 the quantity of pottery finds is considerably reduced. The Levels 11 to 9 show vessel types similar to the Gupta & Post-Gupta ware, though the more refined pottery of the early Gupta period has disappeared. A new type of lid, the cone lid with knob (no. VII.34), gradually replaces the bell-shaped and the bowl-lid. Decoration mainly consists of black painted stripes, swans and peacocks, arches and festoons. This fashion continues, but in Levels 8 to 6 partially moulded jars and bottles with rich relief decoration in Islamic style appear additionally. In Levels 5 to 1 finally the hookah turns up (nos. VIII.13 ff.). The pottery of this time is more or less continuing until today in the area surrounding the now deserted ancient mound of Sonkh.

Period I. Pottery from Levels 40 to 37

Painted Grey Ware

I.1 Bowl, lenticular bottom with carinated edge, conical wall (in-leaning), direct rim. Dark grey, black painted comb-pattern, bottom outside lighter grey, body grey, fine fabric, burnished. No. So II 5.

I.2 Bowl-fragment, shallow paraboloidal bottom, carinated edge, lightly in-curved wall, direct rim. Grey, wall outside reddish ochre, separated by dark grey line from grey bottom, black comb-pattern, fine fabric, burnished. No. So II 2143.



92 Spouted jar with horizontal black painted stripes. Period VI



93 Goblet with moulded bowl and stem. Period VI

I.3 Bowl-fragment, shallow paraboloidal bottom, carinated edge, in-curved wall, direct rim. Light grey, dark grey comb-pattern on inner wall and bottom, very fine fabric, burnished. No. So II 451.

I.4 Fragment of large bowl, shallow bottom, slightly carinated edge, in-curved wall, direct rim. Grey-brown, red polished surface, very fine fabric. No. So II 2355.

I.5 Bowl-fragment, lenticular bottom with carinated edge, conical wall slightly in-leaning, top of rim in-bevelled. Dark grey, fine fabric, burnished. No. So II 3008.

I.6 Bowl, lenticular bottom with slightly carinated edge, in-curved wall. Grey, black and brown-grey comb-patterns, black rim, very thin wall, very fine fabric. No. So II 2337.

I.7 Small bowl, lenticular bottom, up-curved, slightly in-leaning wall, direct tapering rim. Grey, black comb-painting in- and outside, fine fabric. No. So II 448.

I.8 Bowl, hemispherical, slightly in-curved wall, direct rim. Grey to buff to ochre, black to light brown comb-painted patterns, rim black, very fine fabric, polished. No. So II 2338.

I.9 Bowl, hemispherical, in-leaning, upper part of wall straight, rim sharp-edged. Light grey, dark grey comb-painting inside and outside, very fine fabric. No. So II 463.

I.10 Bowl, hemispherical, slightly in-curved wall, direct rim. Rich dark grey comb-painting inside, overlapping to exterior, rim dark grey, very fine fabric. No. So II 449.

I.11 Bowl, hemispherical, section of bottom parabolic, in-curved wall, direct rim. Dark grey, black comb-painting inside and outside, black rim, very thin wall, very fine fabric, burnished. No. So II 2027.

I.12 Complete bowl, hemispherical, ridge around wall, direct rim. Inside grey, outside reddish brown, comb-painted patterns inside red-brown, outside grey-brown, grey body, very fine fabric. No. So I 39.

I.13 Bowl-fragment, hemispherical, bottom parabolic in section, rim in-bevelled, wall grooved. Grey body, black rim, inside and outside black comb-painted patterns, very fine fabric, polished. No. So I 37.

I.14 Bowl-fragment, lenticular base with carinated edge, wall straight, slightly leaning-out. Grey body, comb-painted patterns inside grey-black, outside grey-brown, fine fabric. No. So II 485.

I.15 Bowl-fragment, lenticular base with carinated edge, wall leaning out, slightly curved. Grey body, comb-painted patterns outside light brown, inside black, fine fabric. No. So II 490.

I.16 Fragment of small cup, lenticular bottom with carinated edge, out-curving funnel-wall, grooved. Buff, comb-painting inside, fine fabric. No. So II 2450.

I.17 Fragment of small bottle, recurved neck, direct rim. Brownish grey, brown comb-painting in rim, very fine fabric. No. So II 2756.

Black-and-Red Ware

I.18 Fragment of large bowl, lenticular bottom with carinated edge, funnel-wall, inflected direct rim. Black and red, very fine fabric, polished. No. So II 2354.

I.19 Large bowl, lenticular bottom with slightly carinated edge, in-curved wall, direct rim. Grey body, black and red, fine fabric, polished. No. So II 462.

I.20 Fragment of bowl, lenticular bottom, out-leaning wall with slightly out-curved rim. Red, body brownish grey, very fine fabric, polished. No. So II 2352.

I.21 Fragment of small bowl, near-hemispherical, direct rim with tapering edge. Grey body, glossy black surface, very fine fabric. No. So II 487.

I.22 Bowl-fragment, up-curved, out-leaning wall, flat bottom with small foot-ring, slightly beaded rim. Interior and upper exterior black, bottom red, body mainly grey, in bottom red, fine fabric, polished. No. So II 2142.

I.23 Bowl-fragment, paraboloidal, in-curved upper wall, plain rim. Interior black, exterior black to red, very fine fabric, polished. No. So II 2982.

I.24 Complete bowl, hemispherical, upper wall grooved, direct sharp-edged rim. Black, exterior of bottom red. Grey body, very fine fabric, polished. No. So II 2339.

I.25 Fragment of bowl, carinated edge of lenticular bottom (saggar base), out-curved funnel-wall, direct rim. Black, bottom outside reddish ochre, dark grey body, fine fabric. No. So II 2258.

I.26 Bowl (funnel-beaker), flat bottom, hemispherical lower wall, up-turned middle-ridge, upper wall funnel-shaped. Interior and upper exterior black, lower exterior reddish ochre, very fine fabric, polished. No. So II 2336.

I.27 Fragment of small bowl or wide-mouthed jar, neckless, beaded rim, grooved belly. Grey body, glossy black surface, fine fabric. No. So II 2136.

Associated Grey and Red Wares

I.28 Bowl-fragment, bottom nearly flat, wall in-leaning, direct rim. Black, burnished, fine fabric. No. So II 3039.

I.29 Bowl, hemispherical, slightly in-curved wall, direct rim. Interior buff, wall outside reddish ochre, fine fabric. No. So II 452.

I.30 Bowl-fragment, near hemispherical, direct rim. Grey, exterior dark grey, fine fabric. No. So II 3010.

I.31 Fragment of hemispherical bowl, flat-topped rim. Light brick-red, coarse fabric, hand-modelled. No. So II 3030.

I.32 Fragment of small hemispherical bowl (cup), grooved rim. Grey to dark grey, fine fabric. No. So II 3024.

I.33 Fragment of cylindrical cup, lenticular bottom, slightly in-leaning wall. Grey, fine fabric. No. So II 3011.

I.34 Dish-fragment, flaring sides, slightly out-curved banded rim. Dark grey, fine fabric, burnished. No. So II 3007.

I.35 Bowl-fragment, out-curved wall, in-curved in-beaded rim. Grey, fine fabric. No. So II 2790.

I.36 Fragment of large bowl, convex wall, slightly in-curved double-grooved rim. Reddish ochre, smooth red slip, medium fine fabric, core unoxidized. No. So II 2125.

I.37 Fragment of neckless jar or bulging bowl, inflected ringed club-rim. Grey, very fine fabric. No. So II 2743.

I.38 Fragment of small cup, lenticular bottom, bulging wall, short tapering rim, flat-topped. Buff, fine fabric. No. So II 3041.

I.39 Bottle-fragment, out-curved neck, flaring rim, two holes through neck. Grey, black slip, fine fabric. No. So II 2140.

- I.40 Storage jar, pyriform, angular neck, bow-rim. Brick-red, coarse fabric, red slip, hand-built. No. So II 3120.
- I.41 Storage jar, ovoidal, pointed base, short recurved neck, conical collar-neck. Reddish ochre, coarse fabric, hand-built, beating-marks. No. So II 137.
- I.42 Fragment of cooking jar, lenticular, recurved neck. Brick-red, medium fine fabric, bottom on both sides micaceous. No. So II 1926.
- I.43 Fragment of jar, shoulder-ledge, recurved funnel-neck, direct rim. Brick-red, medium fine fabric. No. So II 2754.
- I.44 Fragment of jar, steep shoulder, recurved neck, bevelled rim. Brick-red, medium coarse fabric. No. So II 3023.
- I.45 Jar-fragment, wide-mouthed, neckless, beaded rim. Reddish brown, core grey, fine fabric, polished on both sides. No. So II 2135.
- I.46 Jar-fragment, wide-mouthed, globular, recurved neck, bevelled rim. Ochre, line of pricked dots on shoulder, medium fine fabric, burnished. No. So II 2049.
- I.47 Jar, globular, recurved neck, beaked rim. Ochre, thin groove below neck, medium fine fabric. No. So II 2048.
- I.48 Jar, globular, wide-mouthed, recurved neck, beaded rim. Ochre, medium fine fabric, burnished. No. So II 2020.
- I.49 Jar, globular, capstan-neck, everted rim. Ochre, two grooves and line of cuneiform pricks on shoulder, medium fine fabric. No. So II 2340.
- I.50 Jar-fragment, globular or pyriform, angular funnel-neck, bevelled rim. Reddish ochre, paddle-marks, medium coarse fabric, hand-built. No. So II 287.
- I.51 Fragment of small jar, carinated wall, recurved neck, club-rim. Brick-red, band of oblique notches above carination, fine fabric, burnished. No. So II 2152.
- I.52 Fragment of small jar, presumably lenticular trunk, neckless, banded rim. Dark brown, fine fabric. No. So II 3047.
- I.53 Jar, globular, shoulder-ledge, capstan-neck, direct flaring rim. Brick-red body, upper trunk and neck dark red vitrified slip, running down over ochre slurry-slip, small circle and semicircle impressed into upper side of rim as potter's mark, fine fabric. No. So II 2440.
- I.54 Small jar, lenticular trunk, funnel-shaped collar-rim. Grey, black slip, fine fabric. No. So II 2081.
- I.55 Tiny globular pot with up-curved cylindrical neck and tapering rim. Reddish brown, smooth surface, oblique notches on shoulder, fine fabric, hand-modelled. No. So II 433.
- I.56 Beaker, lenticular trunk, grooved funnel-neck, direct rim. Reddish ochre, fine fabric. No. So II 2118.
- I.57 Beaker, globular, short funnel-rim. Ochre, medium fine fabric, hand-modelled. No. So II 2439.
- I.58 Fragment of small saucer, concave wall (flaring flange), bevelled edge, upper side of flange slightly concave, stepped up over interior of vessel. Brick-red, medium fine fabric. No. So II 2005.
- Period II. Pottery from Levels 36 to 29*
- a) Levels 36 to 35*
- II.1 Bowl-fragment, nearly flat bottom, bulging sides, slightly recurved thin rim. Grey, outside dark grey, fine fabric. No. So II 454.
- II.2 Bowl-fragment, saggar base, carinated edge of bottom, out-leaning wall, inflected round-edged rim. Grey, fine fabric. No. So II 456.
- II.3 Bowl, lenticular bottom, in-curved wall, tapering direct rim. Grey, micaceous, fine fabric. No. So II 2727.
- II.4 Bowl, lenticular bottom, carinated edge of bottom, slightly in-leaning wall, round-edged direct rim. Dark grey, medium fine fabric. No. So II 544.
- II.5 Bowl, saggar base, slightly convex vertical wall, direct rim. Grey, black slip, medium fine fabric. No. So II 1895.
- II.6 Small bowl, lenticular bottom, up-curved nearly vertical wall, direct rim. Grey, fine fabric. No. So II 545.
- II.7 Bowl, lenticular bottom, up-curved vertical wall, direct rim. Grey, fine fabric. No. So II 453.
- II.8 Fragment of hemispherical basin, flat-topped thick rim. Ochre, medium fine fabric, hand-built. No. So II 2123.
- II.9 Fragment of large bowl, convex wall, club-rim. Brick-red, coarse fabric, hand-built. No. So II 2793.
- II.10 Fragment of small bowl, shallow, flat foot, convex wall, direct rim. Dark grey, fine fabric. No. So II 2847.
- II.11 Cylindrical cup, saggar base, slightly thickened red rim. Light grey, fine fabric. No. So II 15.
- II.12 Cylindrical bowl, slightly bulging wall, saggar base. Grey, near rim reddish, fine fabric. No. So II 467.
- II.13 Fragment of small funnel-bowl, inflected rim with tapering lip, flat bottom. Brick-red, fine fabric. No. So II 98.
- II.14 Cooking vessel, lenticular bottom and side, sharply everted rim with flat top. Brick-red, bottom micaceous on both sides, fine fabric. No. So II 2848.
- II.15 Fragmentary cooking vessel, lenticular, neck slightly concave, out-curved club-rim. Brick-red, bottom micaceous, fine fabric. No. So II 2085.
- II.16 Fragment of jar, capstan neck, direct flaring rim. Brick-red, fine fabric, stamped rectangular potter's mark inside rim. No. So II 113.
- II.17 Fragment of jar, globular?, short recurved neck, club-rim. Brick-red, core unoxidized, trunk slurry-daubed, medium fine fabric. No. So II 2113.
- II.18 Small jar, nearly ovoidal, carinated neck, vertical round-edged rim. Light grey, black slipped, medium fine fabric (chaff-tempered). No. So II 2021.
- II.19 Fragment of jar, globular, recurved neck, flaring round-edged rim, grooved shoulder. Brownish grey, fine fabric. No. So II 83.
- II.20 Jar, globular, recurved funnel-neck, beaded rim. Brick-red, wide-spaced paddle-marks, medium fine fabric. No. So II 1912.
- II.21 Jar, pyriform, banded collar-rim. Brick-red, medium fine fabric. No. So II 1879.

- II.22 Jar, pyriform, grooved concave collar-rim, shoulder slightly carinated and grooved. Brick-red, neck and shoulder red slipped, belly paddle-marked, medium fine fabric. No. So II 1907.
- II.23 Jar, pyriform, conical shoulder, sharply carinated concave rim. Brick-red, medium fine fabric. No. So II 1891.
- II.24 Jar, pyriform, conical shoulder, banded rim. Brick-red, medium fine fabric. No. So II 1862.
- II.25 Small vase, ovoidal, angular out-curved funnel-rim, flat base. Brick-red, medium fine fabric. No. So II 1883.
- II.26 Small vase with bulging lower wall, carinated neck, recurved rim. Grey, medium fine fabric. No. So II 1876.
- II.27 Fragment of jar with steep shoulder, long neck, collar-rim with out-curved grooved lip. Brick-red, smooth surface, groove below neck, medium fine fabric. No. So II 116.
- II.28 Fragment of jar, recurved neck, hyperboloidal collar-rim with middle ridge. Grey-ochre, trunk slurry-daubed, medium fine fabric. No. So II 2080.
- II.29 Fragment of jar, presumably globular, recurved neck, with groove at its base, beaded rim with tapering top-edge. Greyish ochre, coarse fabric (chaff-tempered). No. So II 2079.
- b) Levels 34 to 33*
- II.30 Bowl-fragment, nearly straight slightly in-curved wall, tapering direct rim, saggar-base with flattened centre. Grey, black slip, fine fabric, No. So II 2715.
- II.31 Bowl-fragment, slightly curved nearly vertical wall, saggar-base. Slate-grey, smooth surface, centre inside stamped with concentric circles. No. So II 2399.
- II.32 Fragmentary bowl, up-curved wall, direct rim, flat bottom. Grey, black slip, fine fabric. No. So II 2734.
- II.33 Bowl-fragment, lenticular base, in-curved wall, thick direct rim. Grey, rim black slipped on both sides, medium fine fabric. No. So II 2426.
- II.34 Bowl-fragment, carinated in-leaning rim, curved lower wall, saggar-base. Slate-grey, interior grooved, fine fabric. No. So II 2417.
- II.35 Fragmentary small bowl, hemispherical, whittled bottom, direct rim. Dark grey, body grey, fine fabric. No. So II 2728.
- II.36 Fragment of cup, straight wall, slightly in-leaning, saggar-base. Grey, very fine fabric. No. So II 2702.
- II.37 Large basin, convex wall, grooved neck, club-rim with grooves. Brick-red, coarse fabric. No. So II 3053.
- II.38 Bowl-fragment, vertical wall, saggar-base, flaring rim. Brick-red, bottom both sides micaceous, fine fabric. No. So II 2130.
- II.39 Bowl-fragment, carinated, in-leaning wall, out-curved rim, bevelled, saggar-base. Brown, micaceous, medium fine fabric. No. So II 82.
- II.40 Large pan, saggar-base, flaring wall, broad flange, two lug-handles. Brown, red slipped flange, bottom micaceous, unevenly fired, medium coarse fabric. No. So II 1992.
- II.41 Fragment of bowl with flaring side and up-turned bevelled rim. Brick-red, core unoxidized, fine fabric. No. So II 2694.
- II.42 Funnel-bowl, in-curved rim. Red, fine fabric. No. So II 2716.
- II.43 Shallow funnel-bowl, flaring side, in-curved rim. Brick-red, medium fine fabric. No. So II 100.
- II.44 Funnel-bowl, in-curved collar-rim. Brick-red, medium fine fabric. No. So II 1990.
- II.45 Large bowl, funnel-shaped, carinated and grooved inflected rim, flat bottom. Brick-red, core unoxidized, red slip, coarse fabric. No. So II 1973.
- II.46 Funnel-bowl, inflected rim. Brick-red, medium fine fabric. No. So II 1994.
- II.47 Funnel-bowl, thick rounded rim. Brick-red, medium coarse fabric. No. So II 1962.
- II.48 Vessel-fragment, funnel-shaped, thick in-beaded rim. Brick-red, fine fabric. No. So II 2707.
- II.49 Fragment of heavy bowl, funnel-shaped, flaring bevelled rim with ridge inside (= concave or channelled flange). Brick-red, rim red slipped, medium fine fabric. No. So II 1984.
- II.50 Cooking bowl, lenticular bottom, in-curved wall, everted rim. Brick-red, fine fabric. No. So II 2736.
- II.51 Fragment of cooking vessel, shallow funnel-rim. Grey-brown, black slip, medium fine fabric. No. So II 2738.
- II.52 Fragment of jar, hyperboloidal neck, flaring rim which tapers down to a sharp edge. Light brick-red, fine fabric. No. So II 2735.
- II.53 Fragment of jar, out-curved neck, flaring rim. Ochre, core unoxidized, red slip, medium fine fabric. No. So II 2701.
- II.54 Jar, globular, recurved neck, banded rim. Brick-red, smooth surface, medium fine fabric. No. So II 1835.
- II.55 Jar-fragment, globular, shoulder-ledge, concave flaring band-rim. Brick-red, red slip, micaceous, medium fine fabric. No. So II 1972.
- II.56 Fragment of jar, globular or pyriform, carinated neck, slightly out-curved rim, double-groove on shoulder. Grey, black slip, smooth surface, medium fine fabric. No. So II 1929.
- II.57 Small jar, nearly globular, rim beaded. Brick-red, fine fabric. No. So II 2026.
- II.58 Jar, pyriform, carinated rim. Brick-red, medium fine fabric. No. So II 3079.
- II.59 Jar, narrow neck, globular, flat bottom, steep conical spout, out-curved rim. Brick-red, smooth surface, red slip, medium fine fabric (chaff-tempered). No. So II 1776.
- II.60 Small bulging balluster vase. Brick-red, red slipped, fine fabric. No. So II 2752.
- II.61 Very small vase, baluster-shaped, bevelled rim. Light ochre, medium fine fabric. No. So II 1983.
- II.62 Tortoise-shaped hollow object. Light brick-red, red slip, fine fabric. No. So II 435.
- c) Levels 32 to 31*
- II.63 Bowl-fragment, shallow base, in-curved wall, direct rim. Light grey, fine fabric. No. So II 4

- II.64 Bowl-fragment, saggar-base, straight wall, slightly bulging vertical wall, direct rim. Grey, fine fabric. No. So II 2403.
- II.65 Fragmentary bowl, flattened saggar-base, straight wall in-leaning, direct rim. Grey to black, fine fabric. No. So II 2402.
- II.66 Fragment of shallow bowl with up-curved wall and in-beaded rim. Grey, black slip, fine fabric. No. So II 2349.
- II.67 Bowl-fragment, hemispherical, with in-bevelled rim. Grey, black slip, fine fabric. No. So II 2405.
- II.68 Fragment of deep bowl, hemispherical, with high, steeply on the inside bevelled rim. Dark ochre, inside changing into dark grey, body dark grey, surface smooth. No. So II 2677.
- II.69 Fragment of large bowl, carinated inflected rim. Brick-red, medium fine fabric. No. So II 2724.
- II.70 Large pan, nearly flat saggar bottom, out-leaning wall, flaring rim. Brick-red, micaceous, fine fabric. No. So II 2949.
- II.71 Large pan, rounded saggar-base, short wall, flaring rim. Brick-red, micaceous, fine fabric. No. So II 1858.
- II.72 Bowl, shallow, double carinated, constricted concave rim, saggar-base. Reddish ochre, red slip, medium fine fabric, externally burnished. No. So II 2652.
- II.73 Large pan, saggar-base, vertical slightly concave wall, two vertical semicircular loop-handles. Brick-red, core unoxidized, red slip, bottom micaceous on both sides, medium fine fabric. No. So II 1806.
- II.74 Small funnel-bowl, out-curved wall, up-curved rim. Reddish ochre, fine fabric. No. So II 2682.
- II.75 Small funnel-bowl, carinated in-curved rim. Brick-red, fine fabric. No. So II 2696.
- II.76 Small bowl, up-curved wall. Grey, fine fabric. No. So II 2681.
- II.77 Heavy bowl, shallow funnel-shaped, beaded rim. Brick-red, core unoxidized, interior and rim red slipped, coarse fabric. No. So II 1757.
- II.78 Fragment of large bowl with convex wall, club-rim with sharp edges, open spout (pouring lip). Dark grey, thin black slip, medium fine fabric. No. So II 2425.
- II.79 Jar-fragment, slender neck, long funnel-rim. Black, fine fabric. No. So II 2987.
- II.80 Jar-fragment, globular, very short neck, flaring rim. Brick-red, red slip, neck perforated by four holes, cordon of radial incised notches, medium fine fabric. No. So II 1839.
- II.81 Jar, globular, funnel-neck, bevelled rim, ridge below neck. Light brick-red, upper trunk and neck red slipped, groove on shoulder, medium fine fabric. No. So II 2699.
- II.82 Jar, pyriform, short neck, club-rim. Brick-red, medium fine fabric. No. So II 1807.
- II.83 Jar, pyriform, conical shoulder, bevelled rim. Brick-red, medium fine fabric. No. So II 2942.
- II.84 Jar, pyriform, conical shoulder, banded rim. Brick-red, medium fine fabric. No. So II 1761.
- II.85 Small jar, bulging wall, saggar-base, recurved banded rim. Dark brick-red, shoulder grooved and roughly incised with zig-zag pattern, four perforations below neck, medium fine fabric. No. So II 1785.
- II.86 Small jar, double-carinated, saggar-base. Grey-brown, six holes in neck, criss-cross pattern incised on shoulder, medium fine fabric. No. So II 372.
- II.87 Cooking vessel, hemispherical bottom, carinated conical shoulder, angular funnel-rim. Brick-red, core unoxidized, rim and shoulder red-slipped, medium fine fabric. No. So II 1774.
- II.88 Lid, jar-shaped, dish-like flange. Brick-red, medium fine fabric. No. So II 2704.
- II.89 Lid, saucer-shaped, loop-handle, finger-dented rim. Brick-red, medium coarse fabric, hand-modelled. No. So II 2688.
- d) Levels 30 to 29*
- II.90 Jar, pyriform, concave neck, beaded rim. Reddish ochre, medium fine fabric. No. So II 2302.
- II.91 Jar, pyriform, short neck, sharply carinated rim. Brick-red, medium fine fabric. No. So II 1892.
- II.92 Jar, pyriform, concave neck, banded rim. Brick-red, red slip, groove around neck, trunk strongly paddle-marked, medium fine fabric. No. So II 1893.
- II.93 Small jar, steep shoulder, banded collar-rim. Brick-red, core grey, medium fine fabric. No. So II 2661.
- II.94 Fragment of jar, funnel-rim. Ochre, core unoxidized, medium fine fabric. No. So II 2667.
- II.95 Cooking vessel, bulging wall, shoulder-ledge, conical shoulder, bow-rim. Brick-red, inside ochre, medium coarse fabric (chaff-tempered). No. So II 2673.
- II.96 Cooking vessel, lenticular trunk, bow-rim. Brick-red, potter's mark on shoulder, fine fabric. No. So II 2658.
- II.97 Fragment of cooking vessel, lenticular, shoulder-ridge, recurved rim with concave top. Brick-red, red slip, medium fine fabric. No. So II.1808.
- II.98 Small jar, lenticular, flaring bow-rim. Brick-red, medium fine fabric. No. So II.2784.
- II.99 Fragment of small cup, curved base and wall, out-curved rim. Ochre, fine fabric. No. So II 2666.
- II.100 Fragment of small cup, curved base and wall, out-curved rim. Brick-red, fine fabric. No. So II 2662.
- II.101 Fragment of storage jar, nearly vertical club-rim, grooved. Brick-red, coarse fabric, hand-built. No. So II 2656.
- II.102 Fragment of storage jar, high shoulder, vertical neck, corrugated collar-rim. Ochre, applied finger-dented cordon on shoulder, medium fine fabric. No. So II 2236.
- II.103 Large dish, out-leaning wall, saggar-base, horizontal double-edged flange with convex top. Dark ochre to brick-red, rim black on both sides, core grey, medium fine fabric. No. So II 2312.
- II.104 Funnel-bowl, shallow, up-curved rounded rim, distinct flat foot. Brick-red, fine fabric. No. So II 2391.
- II.105 Small funnel-bowl, slightly convex wall, up-curved tapering rim. Brick-red, fine fabric. No. So II 2657.
- II.106 Funnel-bowl, strongly inflected tapering rim. Grey, core dark grey, fine fabric. No. So II 2664.

- II.107 Fragment of bowl, out-leaning wall, saggar-base, up-turned thick bevelled rim. Brick-red, fine fabric. No. So II 2653.
- II.108 Fragment of bowl, in-curved wall, direct blunt rim. Brick-red, fine fabric. No. So II 2313.
- II.109 Fragment of large dish, flaring side, flat-topped double-beaded rim. Light brick-red, medium fine fabric. No. So II 2654.
- II.110 Votive bowl, hemispherical, flat foot, flaring rim, four finger-cups on rim. Light brick-red, medium fine fabric. So II 2234.

Period III. Pottery from Levels 28 to 25

a) Levels 28 to 27

- III.1 Fragment of globular or lenticular bottle, carinated neck, concentric ledges on shoulder. Brick-red, neck thrown separately, medium fine fabric. No. So II 2225.
- III.2 Bottle, lenticular, short cylindrical neck, beaded rim, saggar-base. Brick-red, medium fine fabric. No. So II 1706.
- III.3 Fragment of bottle, short carinated neck, sharp-edged flat-topped rim, ledge on base of neck. Light brick-red, core grey, neck thrown separately, medium fine fabric. No. So II 2705.
- III.4 Globular jar, cylindrical neck, thick corrugated collar-rim, ledge on shoulder. Brick-red, trunk slurry-daubed, groove on shoulder, medium fine fabric. No. So II 2421.
- III.5 Globular jar, thin-walled, funnel-neck, bevelled collar-rim, ledge on base of neck, groove on shoulder, incised nandyāvarta and svastika on belly. Brick-red, medium fine fabric. No. So II 2850.
- III.6 Globular jar, funnel-neck, beaded rim, groove on shoulder. Ochre, medium fine fabric. No. So II 3002.
- III.7 Globular jar, wide neck, bevelled rim, ledge below neck, oblique notches on shoulder. Brick-red, medium fine fabric. No. So II 2024.
- III.8 Globular jar, conical neck, beaded collar-rim, groove on shoulder, paddle-marks. Brick-red, medium fine fabric. No. So II 3067.
- III.9 Globular jar, short neck, everted rim with sharp edge (beak-rim), trunk paddle-marked. Light brick-red, medium coarse fabric. No. So II 2095.
- III.10 Elongated pyriform jar, beaded rim. Brick-red, medium fine fabric. No. So II 2898.
- III.11 Pyriform jar, slender neck, bevelled rim (beak-rim). Brick-red, bottom grey discoloured, medium fine fabric. No. So II 2750.
- III.12 Big globular jar, funnel-neck with plain rim. Light brick-red, red slip, lower trunk micaceous, fine fabric. No. So II 2911
- III.13 Small globular jar, recurved neck, bevelled rim, three holes through neck. Brick-red, fine fabric. No. So II 2745.
- III.14 Fragment of jar, wide-mouthed, broad bevelled rim. Brick-red, medium fine fabric. No. So II 2201.
- III.15 Big jar, globular, corrugated collar-neck, broad bevelled rim. Brick-red, surface buff, medium coarse fabric. No. So II 2800.
- III.16 Fragment of storage jar, presumably heart-shaped in section, vertical corrugated neck, thick undercut banded rim, applied round moulded plaque of a nandyāvarta and two finger-cupped and notched applied cordons on shoulder. Ochre, red slip, core unoxidized, coarse fabric, hand-built. No. So II 2247.
- III.17 Storage jar, ellipsoidal, steep funnel-neck, in-beaded rim, pointed base. Brick-red, coarse fabric, hand-built. No. So II 2986
- III.18 Oblong jar with downward tapering sides, incurved direct rim. Dark brown, smooth surface, cordon of rough vertical scratched line on shoulder, coarse fabric. No. So II 121.
- III.19 Small jar, barrel-shaped pitcher, funnel-neck, bevelled rim, ridge at neck-base, cordons of grooves around trunk and shoulder, saggar-base. Light brick-red, medium fine fabric. No. So II 2894.
- III.20 Small barrel-pitcher, steep funnel-neck, beaded rim, ridge and band of grooves below neck, no distinct shoulder, saggar-base. Brick-red to buff, medium fine fabric. No. So II 3050.
- III.21 Small jar, broad lenticular base, slightly curved sloping side, grooved and ridged shoulder, cylindrical neck, bevelled rim. Brick-red, medium fine fabric. No. So II 3051.
- III.22 Small jar, double-carinated, flat base, flaring rim, angular neck, side slightly concave, grooved. Brick-red, rim red slipped, medium fine fabric. No. So II 2849.
- III.23 Small jar, spheroidal, funnel-neck, flaring rim. Brown, red slip, medium fine fabric. No. So II 2895.
- III.24 Small jar, spheroidal, funnel-neck, bevelled rim. Brick-red, buff slip, medium fine fabric. No. So II 2896.
- III.25 Small jar, broad lenticular bottom, sloping slightly curved wall with groove, carinated neck, steep funnel-rim. Brick-red, medium fine fabric. No. So II 2611.
- III.26 Small jar, wide-mouthed, double-carinated, short beaded rim, perforated neck, incised zigzag cordon on shoulder. Brick-red, medium fine fabric. No. So II 2215.
- III.27 Small vase, baluster-shape, flat base, angular funnel-rim. Black (originally brick-red), medium fine fabric. No. So II 3046.
- III.28 Small bottle, heart-shaped profile, cylindrical neck, beaded rim, flat base. Brick-red, fine fabric. No. So II 3073.
- III.29 Small jar, wide-mouthed, spheroidal, flat base. Brick-red, medium fine fabric. No. So II 3057.
- III.30 Small jar, lenticular, short bow-rim, convex base. Ochre, red slip, medium fine fabric, bottom whittled. No. So II 3034.
- III.31 Small jar, bulging wall, short recurved rim, flat base. Brick-red, medium fine fabric. No. So II 1662.
- III.32 Cooking jar, globular trunk, slightly carinated concave shoulder, ridge around neck, out-curved flaring rim. Ochre to brick-red, core grey, red slip, medium fine fabric. No. So II 2347.
- III.33 Cooking jar, big, two-third globular trunk, concave carinated shoulder, everted rim. Brick-red, buff slip, medium coarse fabric. No. So II 2925.
- III.34 Cooking jar with steep conical wall, lenticular bottom, shallow conical carinated shoulder, angular flaring funnel-rim, groove around trunk. Ochre, red micaceous slip, medium fine fabric. No. So II 3025.
- III.35 Cooking vessel, lenticular bottom and side, sharply carinated shallow concave shoulder, everted flaring rim. Brick-red, micaceous bottom, fine fabric. No. So II 2188.

III.36 Cooking vessel, lenticular, carination ridge on shoulder, everted rim. Reddish ochre, medium fine fabric. No. So II 2248.

III.37 Funnel-bowl ("common bowl"), carinated rim, flat base. Brick-red, medium coarse fabric. No. So II 3016.

III.38 Small funnel-bowl, up-curved rim, distinct foot. Brick-red, medium fine fabric. No. So II 2534.

III.39 Large bowl, up-curved wall, lenticular bottom, club-rim, two opposite loop-handles with ears. Brick-red, fine fabric. No. So II 2204.

III.40 Large bowl, funnel-wall, inflected carinated rim, flat base. Brick-red, core unoxidized, medium fine fabric. No. So II 2067.

III.41 Large bowl, inflected carinated rim, corrugated, tube-spout with applied ears or eyes. Ochre, red slipped, core unoxidized, coarse fabric. No. So II 2365.

III.42 Bowl, funnel-wall, broad in-beaded rim (flange), flat base. Brick-red, interior red slipped, core unoxidized, medium coarse fabric. No. So II.2730.

III.43 Large bowl, in-curved wall, beaded rim, lenticular base. Ochre, red slipped, fine fabric. No. So II 2865.

III.44 Large bowl, slightly convex wall, grooved rim, flat base, lug-handles. Ochre, red slip, medium fine fabric. No. So II 3105.

III.45 Cauldron, steep funnel-wall, hemispherical base, thick banded rim. Brick-red, coarse fabric, hand-built. No. So II 3115.

III.46 Small bowl (cup), up-curving wall, in-bevelled rim, concave bottom. Dark brick-red, red slipped, fine fabric, bottom and lower wall beat-marked. No. So II 2574.

III.47 Small bowl, slightly in-curved wall, in-bevelled rim, lenticular bottom. Brick-red, red slipped, fine fabric. No. So II 2351.

III.48 Lid, "jar-cum-bowl"(bowl-lid with jar-shaped grip-hole), flat base. Brick-red, medium fine fabric. No. So II 2999.

III.49 Bowl-lid with central cone, flat base. Brick-red, medium coarse fabric. No. So II 2562.

III.50 Dome-lid with flat-topped knob, prominent ridge on shoulder. Ochre, red slip, medium fine fabric. No. So II 2997.

III.51 Small dome-lid with perforated flat-topped knob. Ochre, medium fine fabric. No. So II 2886.

III.52 Double-conical pedestal lamp, flaring everted rim. Brick-red, fine fabric. No. So II 2177.

III.53 Fragment of lid?, domed with short flange, constricted rim. Ochre, under side grey-black, medium fine fabric. No. So II 2303.

III.54 Small ring-stand, double-rimmed, top-side incised chevrons. Light brick-red, medium fine fabric. No. So II 2878.

III.55 Pedestal in shape of stool, corrugated foot. Brick-red, coarse fabric. No. So II 2223.

III.56 Tall ring-stand, sloping wall, short flange. Ochre, medium coarse fabric. No. So II 2237.

III.57 Sprinkler spout, seven holes, knob-shape, base decorated with impressed dots and applied rings. Brick-red, core unoxidized, coarse fabric. No. So II 2612.

b) Levels 26 to 25

III.58 Bottle, hemispherical lower trunk, conical shoulder, steep funnel-neck with throwing-ridges, bevelled rim. Brick-red, core unoxidized, coarse fabric. No. So II 2510.

III.59 Bottle, apple-shaped, saddle-shoulder, triple-rimmed neck, grooves on shoulder and belly. Reddish ochre, red slip, medium fine fabric. No. So II 2726.

III.60 Bottle-fragment, short carinated neck, flat-topped rim, ridge on base of neck. Brick-red, core unoxidized, medium coarse fabric. No. So II.1645.

III.61 Small bottle, heart-shape profile, flat protruding foot, ridge below slender slightly out-curved neck, bevelled rim. Brick-red, medium fine fabric. No. So II 2553.

III.62 Small bottle, lenticular, flat base, short cylindrical neck, bow-rim. Ochre, fine fabric. No. So II 2036.

III.63 Small bottle, globular, narrow flat base, near-cylindrical neck, funnel-rim with restricted base. Ochre, medium fine fabric. No. So II 2044.

III.64 Pyriform jar, recurved bevelled rim, lower trunk paddle-marked. Brick-red, medium fine fabric. No. So II 2508.

III.65 Globular jar, recurved neck, beaded rim, two grooves on shoulder. Brick-red, medium fine fabric. No. So II 2447.

III.66 Globular jar, nearly horizontal shoulder, slightly out-curved neck, beaded rim, ridge at base of neck, two grooves on shoulder. Brick-red, core unoxidized, red slip, medium fine fabric (strongly chaff-tempered). No. So II 1988.

III.67 Globular jar, shoulder-ledge, slightly out-curved neck, banded collar-rim. Dark red burnished slip on ochre, core unoxidized, medium coarse fabric. No. So II 2721.

III.68 Globular jar, high shoulder, short neck, long banded funnel-rim, ridge at base of neck. Brick-red, core unoxidized, red slip, medium fine fabric. No. So II 1987.

III.69 Globular jar, funnel-neck, flaring rim, three spouts in unusual shape. Brick-red, core unoxidized, medium fine fabric. No. So II 2954.

III 70 Small jar, conical, lenticular base, grooved shoulder, ridge on base of neck, out-curved bevelled collar-rim. Brick-red, medium fine fabric. No. So II 2979.

III.71 Small jar, conical wall, lenticular base, waisted below shoulder, flaring flat-topped rim, ridge below neck. Greyish ochre, medium fine fabric. No. So II 2647.

III.72 Small jar, waisted, lenticular bottom, bevelled funnel-rim. Brick-red, fine fabric. No. So II 2289.

III.73 Small jar, pyriform, slightly waisted, flat foot, bevelled funnel-rim. Brick-red, medium fine fabric. No. So II 2587.

III.74 Small jar, pyriform, lenticular base, bevelled funnel-rim. Ochre, medium coarse fabric. No. So II 2043.

III.75 Small jar, shallow paraboloidal bottom, vertical wall, conical shoulder with groove, ridge below cylindrical neck, bevelled rim (beaked). Reddish ochre, red slip, medium coarse fabric. No. So II 1959.

III.76 Small vase, heart-shape profile, flat foot, angular hyperboloidal neck, bevelled rim. Ochre, medium fine fabric. No. So II 2038.

- III.77 Small jar, balluster-shape. Brick-red, core unoxidized, medium fine fabric. No. So II 1967.
- III.78 Small jar, biconical, flat bottom, recurved neck, bevelled rim. Brick-red, medium fine fabric. No. So II 2968.
- III.79 Small jar, double-carinated, angular funnel-neck, bevelled rim, flat foot, wall conical. Brick-red, fine fabric. No. So II 1966.
- III.80 Small jar, pyriform, flat foot, short bevelled funnel-rim. Brick-red, medium fine fabric. No. So II 2870.
- III.81 Small jar, lenticular, flat foot, short, short bevelled rim. Brick-red, fine fabric. No. So II 2332.
- III.82 Storage jar, heart-shape profile, pointed base, cylindrical corrugated neck, banded collar-rim, three applied medallions of nandyāvarta, svastika and lotus rosette, two applied and notched cordons. Light brick-red, upper half red slipped, coarse fabric, hand-modelled. No. So II 2966.
- III.83 Small cooking jar, lenticular, shoulder-carination, curved banded rim. Brick-red, micaceous, medium fine fabric. No. So II 2554.
- III.84 Cooking jar, carinated trunk, lenticular bottom, out-curved flaring rim. Ochre, medium fine fabric. No. So II 2039.
- III.85 Small cooking jar, lenticular trunk, grooved shoulder-carination, out-curved rim. Reddish ochre, fine fabric. No. So II 2555.
- III.86 Small jar in shape of cooking vessel, lenticular, small ridge around belly, groove on shoulder, oblique stamped ornaments, short angular funnel-rim. Black, fine fabric. No. So II 2299.
- III.87 Funnel bowl, wall slightly out-curved, short upturned club-rim, flat foot. Brick-red, medium fine fabric. No. So II 3099.
- III.88 Funnel-bowl, rim stepped, sharply bevelled. Brick-red, medium coarse fabric. No. So II 2639.
- III.89 Large cooking dish, lenticular bottom, carinated out-leaning wall, curved and in-beaded flange. Brick-red, red slip, bottom micaceous on both sides, medium fine fabric. No. So II 2709.
- III.90 Large cooking dish, flat bottom, inflected wall with two grooves, everted rim. Brick-red, core unoxidized, bottom inside micaceous, medium fine fabric. No. So II 2531.
- III.91 Heavy bowl, out-leaning wall, banded rim, flat bottom, interior concave. Brick-red, core unoxidized, coarse fabric. No. So II 2034.
- III.92 Fragment of large funnel-bowl, flat foot, in-beaded bevelled rim. Brick-red, fine fabric. No. So II 2298.
- III.93 Funnel-bowl, flaring flange, flat base, flange separated from trunk by interior ridge. Brick-red, medium fine fabric. No. So II 2238.
- III.94 Basin, lenticular bottom, in-curving wall, vertical collar-rim, open spout. Reddish ochre, red slip, fine fabric. No. So II 2751.
- III.95 Basin, heavy, funnel-shaped, flat foot, carinated conical rim. Brick-red, medium fine fabric. No. So II 2383.
- III.96 Large basin, flaring slightly curved wall, inflected cordoned rim, flat base. Reddish ochre, smooth red slip on rim, medium coarse fabric. No. So II 2916.
- III.97 Large dish, lenticular base, vertical corrugated wall, thick in-beaded curved flange, two eared grooved oblique loop handles. Brick-red, medium coarse fabric. No. So II 3060.
- III.98 Large dish, flat bottom, cylindrical wall, two vertical circular loop-handles. Brick-red, mica-slip, medium fine fabric. No. So II 2741.
- III.99 Bowl, curved bottom and wall, double-beaded flat-topped rim, presumably three triangular eared spouts, traces of three legs. Ochre, red slip outside, fine fabric. No. So II 2946.
- III.100 Fragment of large heavy basin, hemispherical, band-rim with impressed notches and applied knobs. Brick-red, core unoxidized, interior sooty, coarse fabric, hand-built. No. So II 2145.
- III.101 Fragment of large cauldron, in-curved wall, banded club-rim. Brick-red, coarse fabric, hand-built. No. So II 2124.
- III.102 Fragment of large basin, funnel-wall, profiled and finger-dented club-rim. Ochre, red slipped rim and interior, Coarse fabric. No. So II 3078.
- III.103 Small bowl, convex bottom, constricted neck, angular funnel-rim, in-bevelled. Brick-red, red slipped, fine fabric. No. So II 2539.
- III.104 Cup, nearly cylindrical, rounded bottom with concave centre, beaded rim. Greyish ochre, fine fabric. No. So II 2615.
- III.105 Cup, paraboloidal, flat foot, wall grooved, direct bevelled rim. Brick-red, medium fine fabric. No. So II 1979.
- III.106 Small cup, carinated, out-curved wall, direct bevelled rim, flat foot. Brick-red, medium fine fabric. No. So II 2274.
- III.107 Cup, protruding carination, flat foot, cylindrical upper wall, direct rim. Brick-red, fine fabric. No. So II 1888.
- III.108 Lid (stopper), “jar-cum-bowl”, i.e. in the shape of a small globular jar with funnel rim connected with a flange protruding from the upper trunk. Ochre, medium fine fabric. No. So II 2287.
- III.109 Lid (cover), conical, broad nearly flat knob, high cylindrical rim. Brick-red, medium coarse fabric. No. So II 2546.
- III.110 Small libation-vessel, flattened globular neckless trunk, long conical spout. Light brick-red, medium fine fabric, hand-formed. No. So II 2281.
- III.111 Ring-stand, concave wall, both rims bevelled, one rim decorated with impressed triangles, middle part triple-grooved. Brick-red, red slip, medium fine fabric. No. So II 2293.

Period IV. Pottery from Levels 24 to 23

- IV.1 Bottle, heart-profile trunk, long bulging neck, banded rim, grooves on shoulder. Brick-red, core and interior grey, medium fine fabric. No. So II 2485.
- IV.2 Jar, globular, wide mouth, angular funnel-neck, flaring rim. Reddish ochre, red slipped except bottom, core unoxidized, medium fine fabric. No. So II 2693.
- IV.3 Fragment of jar, neck-less, broad double-beaked rim. Brick-red, cordon of stamped festoons below rim, medium fine fabric. No. So II 2472.
- IV.4 Jar-fragment, globular, wide-mouthed, cylindrical neck with middle ridge and ridge below, beaked rim. Ochre, medium fine fabric (chaff-tempered). No. So II 2082.

- IV.5 Jar, globular, short up-curved neck, corrugated collar-rim. Brick-red, medium fine fabric. No. So II 107.
- IV.6 Jar, globular, wide up-curved neck, ringed rim, ridge below neck, five stamped nandyāvartas on shoulder. Brick-red, red slipped except on bottom, medium fine fabric. No. So II 2286.
- IV.7 Jar, globular, near-cylindrical neck, bevelled and corrugated rim, slightly concave inside, ridge below neck, groove on shoulder. Reddish ochre, red slipped, medium fine fabric. No. So II 2988.
- IV.8 Big jar, globular, short neck, high corrugated out-leaning rim with thick bevelled lip and concave interior, slender conical spout with dented base on shoulder, ridge below neck. Ochre, upper half red slipped, finger-made slurry-arches around belly, medium coarse fabric. No. So II 2977.
- IV.9 Fragment of big jar, globular, funnel-neck, square club-rim, ridge below neck, band of thin grooves on shoulder. Brick-red, medium coarse fabric. No. So II 2588.
- IV.10 Jar-fragment, globular, steep corrugated funnel-neck, direct rim, ridge below neck, grooves on shoulder. Ochre, red burnished slip, fine fabric. No. So II 2627.
- IV.11 Jar, near-globular, angular steep funnel-neck, flat-topped rim, two grooves below, ridge below neck, five nandyāvartas and five rosettes stamped alternately on shoulder and upper trunk. Brick-red, red slipped, medium fine fabric. No. So II 2230.
- IV.12 Jar, globular, wide mouth, funnel-neck, concave-topped rim. Brick-red, dark red slip, medium fine fabric (chaff & gravel-tempered), unevenly beaten trunk. No. So II 1928.
- IV.13 Small jar, curved sloping wall, broad lenticular base, angular out-curved neck, bevelled rim, ridge below neck, grooves on shoulder. Brick-red, medium fine fabric. No. So II 1634.
- IV.14 Jar, barrel-shape with downward tapering wall, lenticular bottom, recurved neck, bevelled rim, bands of grooves on wall. Brick-red, medium coarse fabric. No. So II 2840.
- IV.15 Small vase, baluster-shape, bevelled rim, flat bottom. Reddish ochre, core in part unoxidized, fine fabric. No. So II 2697.
- IV.16 Small vase, double-carinated and waisted (groove), flat foot, flaring funnel-neck, out-curved rim. Light brick-red, medium fine fabric. No. So II 2406.
- IV.17 Small jar, double-carinated, tapering upwards, flat foot, funnel-neck, bevelled rim. Brick-red, fine fabric. No. So II 2500.
- IV.18 Small jar, conical, restricted flat foot, short bevelled funnel-rim. Brick-red, fine fabric. No. So II 2476.
- IV.19 Small jar, carinated shoulder, narrow flat foot, beaded rim. Brown, very fine fabric. No. So II 2601.
- IV.20 Small jar, biconical, angular up-curved bevelled funnel-rim. Brick-red, fine fabric. No. So II 2636.
- IV.21 Small jar, globular, broad flat foot, recurved bevelled funnel-rim, ridge below rim. Ochre, medium fine fabric. No. So II 2160.
- IV.22 Small jar, ovoidal, flat foot, steep funnel-neck, ridge below neck. Dark brick-red, medium fine fabric. No. So II 2645.
- IV.23 Small jar (cup), globular, narrow flat foot, short vertical bevelled rim. Brick-red, medium fine fabric. No. So II 126.
- IV.24 Small jar, lenticular, flat foot, wide ridged and hollowed neck, double-beaked rim, two grooves around belly. Brick-red, medium fine fabric. No. So II 2346.
- IV.25 Storage jar, ovoidal, pointed base, short angular club-rim. Light brick-red, core unoxidized, also inner surface, coarse fabric, hand-built and beaten. No. So II 2637.
- IV.26 Fragment of storage jar, vertical short ridged neck, flat-topped club-rim. Light brick-red, red-slipped, medium coarse fabric, hand-built. No. So II 2595.
- IV.27 Fragment of storage jar, broad shoulder, recurved neck with notched ridge below it, double-beaded rim. Brick-red, red slipped, core unoxidized, coarse fabric. No. So II 2446.
- IV.28 Fragment of storage jar, steep funnel-neck, corrugated broad beaked rim, ridge below neck. Reddish ochre, red slip, core unoxidized, coarse fabric, hand-built. No. So II 2427.
- IV.29 Fragment of bowl, convex wall, restricted neck, funnel-rim with concave interior, flat top. Brick-red, smooth red slip, fine fabric, beating-marks. No. So II 2492.
- IV.30 Bowl, convex wall, restricted neck, short beaded rim, flat bottom, three grooves around belly. Reddish ochre, red slipped in- and outside, core unoxidized, medium fine fabric. No. So II 2621.
- IV.31 Small bowl, convex wall, flat bottom, slightly restricted neck, club-rim, two grooves around belly. Brick-red, smooth red slip, medium fine fabric. No. So II 2009.
- IV.32 Large dish or pan, nearly flat bottom, funnel-wall, two opposite loop-handles. Ochre, core unoxidized, medium coarse fabric, hand-built. No. So II 2018.
- IV.33 Large dish or pan, lenticular bottom, vertical carinated wall, angular ringed flange. Brick-red, core unoxidized, exterior of wall and both sides of flange red slipped, bottom micaceous on both sides, medium coarse fabric. No. So II 1941.
- IV.34 Bowl, lenticular trunk, slightly out-leaning neck, ringed rim (ring flange), belly grooved, small ledge between trunk and neck. Brick-red, red slip, core unoxidized, fine fabric. No. So II 408.
- IV.35 Bowl-fragment, convex wall with slight carination at inflection point, nearly flat bottom, out-curved neck, concave flange. Ochre, smooth red slip, fine fabric. No. So II 2315.
- IV.36 Fragment of large heavy bowl, shallow funnel-shape, flat base, rim grooved outside. Brick-red, interior smoothed, scratched nandyāvarta and svastika on wall, coarse fabric. No. So II 2418.
- IV.37 Bowl, shallow funnel-shape, flange with upturned edge. Brick-red, core unoxidized, medium coarse fabric. No. So II 2641.
- IV.38 Cup, hyperboloidal (capstan-shaped), saggar-base, beaded rim with groove, middle groove and groove above base carination. Brick-red, red slip, medium fine fabric. No. So II 2710.
- IV.39 Cup, capstan-shaped, restricted flat foot, flaring rim. Brick-red, medium fine fabric. No. So II 1844.
- IV.40 Cup, cylindrical, saggar-base, thick wall, two grooves, plain rim. Brick-red, core unoxidized, medium coarse fabric. No. So II 1851.

- IV.41 Small bowl (cup or beaker), lenticular trunk, cylindrical corrugated rim. Brick-red, exterior and inner rim red slipped, medium coarse fabric. No. So II 1843.
- IV.42 Small cup or chalice, carinated, protruding foot, bevelled funnel-rim. Brick-red, fine fabric. No. So II 2520.
- IV.43 Small bowl, carinated, flat foot, funnel-rim. Brick-red, medium fine fabric. No. So II 2613.
- IV.44 Small bowl, carinated, flat narrow foot, conical in-bevelled neck. Brick-red, fine fabric. No. So II 2646.
- IV.45 Funnel-bowl, flat foot, up-curved collar-rim. Brick-red, medium fine fabric. No. So II 2548.
- IV.46 Funnel-bowl, flat foot, carinated up-curved rim with sharp edge. Brick-red, medium fine fabric. No. So II 2480.
- IV.47 Small shallow funnel-bowl, flat foot, beaded rim. Brick-red, fine fabric. No. So II 2010.
- IV.48 Small bowl, broad flat foot, funnel-wall, out-curved rim. Brick-red, medium fine fabric. No. So II 2429.
- IV.49 Cooking vessel, carinated, lenticular, angular funnel-neck, flaring ringed rim. Reddish ochre, red slip, bottom micaceous, medium fine fabric. No. So II 2976.
- IV.50 Fragment of cooking vessel, presumably hemispherical trunk, carinated conical shoulder with grooves, out-curved neck, everted rim. Brick-red, medium fine fabric. No. So II 2499.
- IV.51 Fragment of cooking vessel, double-carinated, concave wall, lenticular bottom, conical shoulder, neckless beaded rim. Brick-red, medium fine fabric. No. So II 2407.
- IV.52 Bowl-lid with jar-shaped grip-hole, thick flange, flat bottom. Brick-red, core unoxidized, flange and upper side red slipped, medium fine fabric. No. So II 1977.
- IV.53 Bowl-lid with rimmed grip-hole, flat bottom, in-beaded flange. Light brick-red, interior red slipped, medium fine fabric, bottom whittled. No. So II 1709.
- IV.54 Bowl-lid with central knob, grooved flange, lenticular bottom. Brick-red, medium coarse fabric. No. So II 2029.
- IV.55 Bell-shaped lid with pointed knob, raised notched cordon on shoulder, shoulder decorated with incised lotus pattern and pricked dots. Brick-red, fine fabric. No. So II 2058.
- IV.56 Strainer in the shape of a globular jar, wide short neck with inner ridge and concave plains, wide central hole and four or five small holes in bottom. Brick-red, smooth red slip, traces of black paint on shoulder, medium fine fabric. No. So II 2585.
- IV.57 Fragment of strainer in the shape of a bowl, restricted neck, angular funnel-rim, lenticular bottom and wall, many small holes. Brick-red, medium fine fabric. No. So II 2255.
- IV.58 Pedestal lamp, simple bowl with bevelled rim, stem solid. Ochre, red slipped, medium fine fabric, hand-modelled. No. So II 2156.
- IV.59 Lamp or libation-vessel, globular trunk, twin tubular spout, fish-tail handle with hole. Black-grey, medium fine fabric, hand-modelled. No. So II 2211.
- IV.60 Large ring-stand, hyperboloidal, one club-rim, one bevelled rim, perforated wall. Dark brick-red, very coarse fabric, hand-modelled. No. So II 2788.

- IV.61 Large ring-stand, capstan-shaped, one end wider than the other. Brick-red, very coarse fabric, hand-modelled. No. So II 2967.
- IV.62 Knob (of lid?), hollow, capstan-shaped, slightly raised centre. Ochre, smooth, medium fine fabric. No. So II 2221.

Period V. Pottery from Levels 22 to 16

- V.1 Bottle-fragment, long neck, out-curved disc-shaped flange, central cone with narrow channel. Brick-red, red slip, medium fine fabric, ("Sprinkler-Jar"). No. So II B 22
- V.2 Bottle-fragment, long neck, slightly concave wall, bevelled rim. Brick-red, red slip, medium fine fabric. No. So II B 27.
- V.3 Bottle-fragment, long concave neck, conical collar-rim. Brick-red, red slip, medium fine fabric. No. So II B 25.
- V.4 Bottle-fragment, long concave neck, high nearly cylindrical collar-rim. Brick-red, red slip, medium fine fabric. No. So II B 26.
- V.5 Bottle-fragment, ovoidal, flat bottom, horizontal double-grooved shoulder (neck missing, probably of type V.3 or 4). Buff to brick-red, smooth red slipped surface, medium fine fabric. No. So II 1816.
- V.6 Jug, globular, lenticular bottom, steep spout, concave neck, concave banded rim, wide eared loop-handle from belly to rim, bases of handle and spout dented. Brick-red, core unoxidized, smooth surface, red slip, fine fabric. No. So II 1314.
- V.7 Bottle-fragment, globular, concave neck, beaked rim, vertical ridge on shoulder. Brick-red, interior grey, medium fine fabric. No. So II.2396.
- V.8 Bottle-fragment, tapering neck ringed, concave bevelled rim. Brick-red, smooth red slip, medium fine fabric. No. So II 1449.
- V.9 Small bottle, heart-shaped, flat foot, near-cylindrical neck, flat-topped rim, ridge below neck. Dark brick-red, traces of red slip, medium fine fabric. No. So II 2861.
- V.10 Bottle-fragment, slender steep conical neck with prominent collar, two grooves, in-bevelled rim. Brick-red, core unoxidized, smooth surface, red slip, medium fine fabric. No. So II 1455.
- V.11 Jar, globular, recurved neck, bevelled rim, groove below neck. Light brick-red, medium fine fabric. No. So II 1128.
- V.12 Jar, globular, shoulder ledge, recurved neck, chamfered collar-rim. Ochre, light red spots, medium fine fabric. No. So II 2180.
- V.13 Jar, globular or ovoidal, cylindrical neck, chamfered banded rim. Brick-red, smooth surface, medium fine fabric. No. So II 1529.
- V.14 Jar, globular, thick banded rim, recurved neck, slender tubular spout. Ochre, medium fine fabric, pressed out of shape. No. So II 2270.
- V.15 Jar, heart-shaped, short wide recurved neck, beaked rim. Light brick-red, fine fabric. No. So II 2474.
- V.16 Big jar, ovoidal, recurved neck, out-leaning banded rim. Ochre to brick-red, core unoxidized, medium fine fabric. No. So II 2269
- V.17 Fragment of big jar, banded grooved rim. Brick-red, medium fine fabric. No. So II 2463.

- V.18 Fragment of jar, funnel-neck, flaring bevelled rim, ridge below neck, grooves and stamped nandyāvarta on shoulder. Brick-red, core unoxidized, fine fabric. No. So II 2483.
- V.19 Jar, globular, recurved neck, corrugated collar-rim, grooves and stamped nandyāvartas on base of neck. Brick-red, core unoxidized, smooth red slip on upper half and inside neck, medium coarse fabric. No. So II 2017.
- V.20 Jar, globular, funnel-neck, rim in the shape of a concave-topped flange, spout conical with dented base, neck and base of neck grooved, rayed arches and nandyāvartas stamped around belly (the spout was attached after stamping the ornaments). Light brick-red, medium coarse fabric. No. So II 2686.
- V.21 Jar, globular, short bulging funnel-neck, beaded rim, ridge below neck, grooved shoulder with stamped nandyāvartas and rosettes. Dark grey, smooth surface, fine fabric. No. So II 2838.
- V.22 Big jar, globular, recurved neck, ribbed band-rim. Light brick-red, trunk slurry-daubed, medium fine fabric. No. So II 3096.
- V.23 Jar-fragment, globular, recurved neck, deeply hollowed rim with grooves, grooves below neck, carinated spout with beaded rim and dented base, stamped rosettes on shoulder. Brick-red, core unoxidized, medium fine fabric. No. So II 2584.
- V.24 Jar-fragment, heart-shaped outline, capstan neck, beaded rim, neck grooved, impressed and incised linear ornaments on shoulder. Ochre, medium fine fabric. No. So II 2803.
- V.25 Jar, pyriform, out-curved neck, beaked rim, ridge below neck. Brick-red, fine fabric. No. So II 532.
- V.26 Jar-fragment, globular?, short neck, concave oblique band-rim. Dark brick-red, core unoxidized, medium coarse fabric. No. So II 2806.
- V.27 Jar-fragment, globular, short recurved neck, flaring ringed rim, grooved shoulder, three parallel vertical incised strokes on shoulder. Brick-red, fine fabric. No. So II 2276.
- V.28 Jar-fragment, globular, wide-mouthed short funnel-neck, flaring externally grooved in-beaded rim, ridges below neck, stamped festoons of rays on shoulder. Dark brick-red, red slipped, medium fine fabric. No. So II 781.
- V.29 Jar, globular, carinated shoulder with upturned edge, up-curved neck, grooved band-rim. Brick-red, slurry-daubed trunk, medium fine fabric. No. So II 2250.
- V.30 Tube-spout with beaded rim, part of a non-globular vessel. Brick-red, red slipped, fine fabric. No. So II B 14.
- V.31 Tube-spout with crop. Red, medium fine fabric. No. So II 2087.
- V.32 Tube-spout of jar, conical, small applied longitudinal keel. Buff, medium fine fabric, hand-modelled. No. So II 2304.
- V.33 Tube-spout of jar, shape of makara's head. Brick-red, red slipped, fine fabric. No. So II 2798.
- V.34 Tube-spout in shape of a makara's head. Light brick-red, fine fabric, hand-modelled. No. So II 2802.
- V.35 Tube-spout of jar, curved up, with grooves and makara's nostrils, base-dented (pit-marked), flanked by ears, portion of the wall covered with incised grooves and impressed circles, semi-circles, and dots. Brick-red, fine fabric, hand-modelled. No. So II 2073.
- V.36 Crop-spout of jar, four notches on each side of base, upper end grooved. Light brick-red, smooth surface, fine red slip, medium fine fabric. No. So II 1354.
- V.37 Small double-carinated jar, flat foot, concave wall, short neck, bevelled collar-rim. Brick-red, fine fabric. No. So II 1008.
- V.38 Small jar, globular, funnel-neck, rim with tapering edge. Dark ochre, fine fabric, hand-modelled. No. So II 2075.
- V.39 Small jar, globular to heart-shaped, recurved neck, bevelled rim, flat foot. Dark brick-red, smooth red slip, medium coarse fabric. No. So II 887.
- V.40 Small jar, carinated (biconical), flat foot, recurved neck, bevelled rim. Brick-red, fine fabric. So II 618.
- V.41 Small jar, lenticular, shoulder-ridge, flat foot, steep funnel-neck, plain rim. Brick-red, fine fabric. No. So II 1661.
- V.42 Small jar, double-carinated, short neck, banded rim, flat foot. Brick-red, medium fine fabric. No. So II 2343.
- V.43 Small jar, carinated, angular short neck, bevelled rim, flat foot. Brick-red, medium fine fabric. No. So II 2501.
- V.44 Small jar, carinated (biconical), wide mouth, short recurved neck, flaring bevelled rim, flat bottom. Dark brick-red, medium fine fabric. No. So II 2859.
- V.45 Small jar, carinated, saggar-base, angular funnel-neck. Brick-red, medium fine fabric. No. So II 597.
- V.46 Small jar, up-turned carination, hemispherical lower trunk, flat foot, conical shoulder, short recurved neck, beaked rim. Brick-red, fine fabric. No. So II 1569.
- V.47 Small jar, globular, recurved neck, beaded rim, flat bottom, groove on belly. Reddish ochre, medium coarse fabric. No. So II 2148.
- V.48 Small jar, globular, steep funnel-neck, flat-topped rim, ridge below neck, grooves on belly, flat bottom. Ochre, interior black dotted, medium coarse fabric. No. So II 2228.
- V.49 Jar, ovoidal, slightly concave neck, banded rim, flat bottom. Brick-red, medium coarse fabric, crudely made. No. So II 1190.
- V.50 Storage jar, elongated ovoidal, short neck, club-rim, pointed base. Ochre, slurry-washed, coarse fabric, hand-built. No. So II 960.
- V.51 Storage jar, ovoidal, short neck, club-rim, tapering narrow flat base. Brick-red, smooth surface, red slip, medium coarse fabric, hand-built. No. So II 1520.
- V.52 Storage jar, ovoidal, wide mouth, club-rim without neck, tapering convex base. Reddish ochre, slurry-washed, coarse fabric, hand-built. No. So II 904.
- V.53 Cooking vessel, carinated, lenticular bottom, conical wall, out-curved neck, band-rim. Brick-red, medium fine fabric. No. So II 1707.
- V.54 Cooking vessel, carinated, deep lenticular bottom and lower wall, convex shoulder, recurved neck, flaring rim, concave on top. Brick-red, red slipped upper trunk and rim, slurry-daubed below, medium fine fabric. No. So II 1280.
- V.55 Big cooking vessel, carinated, hemispherical lower trunk and bottom, slightly convex shoulder, recurved neck, flaring rim, grooved on top. Brick-red, core grey, medium fine fabric. No. So II 2207.

- V.56 Fragment of cooking vessel, conical shoulder, grooved, angular neck, finger-dented part of rim. Light brick-red, medium fine fabric. No. So II 2288.
- V.57 Heavy bowl, funnel-wall, flat bottom, slightly in-curved carinated and grooved rim, tapering edge. Brick-red, core unoxidized, coarse fabric. No. So II 985.
- V.58 Heavy bowl, shallow funnel-shape, grooved club-rim, flat bottom. Brick-red, interior smooth, coarse fabric. No. So II 2218.
- V.59 Bowl, nearly hemispherical, flat bottom, in-curved band-rim, carinated, grooved, with sharp edge. Brick-red, interior smooth, medium coarse fabric. No. So II 1598.
- V.60 Heavy bowl, funnel-wall, flat bottom, club-rim with concave neck. Brick-red, interior red slipped, medium fine fabric. No. So II 986.
- V.61 Large bowl, lenticular bottom and wall, carinated concave neck, everted rim with hanging lug-handle. Reddish ochre, medium fine fabric. No. So II 2171.
- V.62 Bowl, funnel-shaped, flat bottom, out-curved plain rim, double groove inside. Brick-red, core unoxidized, traces of red slip, medium fine fabric. No. So II 1801.
- V.63 Large dish or pan, cylindrical wall, carinated at base, grooved in middle part, bottom flat, two vertical eared loop-handles on rim. Brick-red, core unoxidized, bottom micaceous on both sides, medium coarse fabric. No. So II 1710.
- V.64 Large bowl, lenticular bottom and wall, in-leaning band-rim, flaring open spout. Reddish ochre, smooth red slip outside, medium fine fabric. No. So II 2872.
- V.65 Bowl, lenticular bottom, slightly conical convex wall, band-rim with inner carination. Light brick-red, smooth reddish slip, fine fabric. No. So II 2675.
- V.66 Fragment of very large bowl or cauldron, bulging wall, strongly inflected club-rim, tube-spout in shape of a lion's or tiger's head, framed by applied notched ridges (rope-pattern). Brick-red, ochre slip, core unoxidized, coarse fabric, hand-built. No. So II 436.
- V.67 Cauldron, steep funnel-shape, flat bottom, club-rim, brick-red, core unoxidized, coarse fabric, hand-built. No. So II 1560.
- V.68 Cauldron, concave wall, saggar-base, double-beaded rim, lug-handles attached to rim. Brick-red, coarse fabric. No. So II 2331.
- V.69 Strainer, cauldron-shaped, hemispherical, direct rim, lug-handles attached to rim, wide hole in bottom. Brick-red, core unoxidized, medium coarse fabric. No. So II 953.
- V.70 Fragment of small vase, thick convex wall, protruding flat-foot, grooved upper wall. Light brick-red, core unoxidized, medium fine fabric. No. So II 2322.
- V.71 Goblet, carinated, protruding flat foot, short stem, funnel-shaped lower trunk, out-curved plain round-edged rim. Brick-red, medium fine fabric. No. So II 1324.
- V.72 Small cup, carinated, flat foot, concave corrugated wall, bevelled rim. Brick-red, fine fabric. No. So II 2359.
- V.73 Small dish, funnel-shaped, flat bottom, horizontal flange. Brick-red, medium fine fabric. No. So II 2518.
- V.74 Bowl, waisted, lenticular bottom, slightly beaded rim. Brick-red, smooth red slip, fine fabric. No. So II 2220.
- V.75 Deep bowl, hemispherical lower wall, narrow concave (pushed in) bottom, cylindrical upper wall, short bow-rim. Brick-red, smooth red slip, fine fabric, No. So II 2387.
- V.76 Cup, globular, thick beaded rim. Reddish ochre, micaceous, fine fabric, beating-marks. No. So II 2158.
- V.77 Small dish (saucer), shallow funnel-shape, band-rim, flat distinct foot. Brick-red, medium fine fabric. No. So II 1168.
- V.78 Small dish, funnel-shape, thick corrugated band-rim, flat foot. Brick-red, fine fabric. No. So II 2526.
- V.79 Tiny bowl, slightly conical wall, corrugated, distinct flat foot. Brick-red, fine fabric. No. So II 2523.
- V.80 Dish, very thick, flat bottom, up-curved wall, beaded rim, lenticular interior. Ochre, red slip, coarse fabric. No. So II 1004.
- V.81 Small bowl, curved bottom and wall, plain in-curved rim, decoratively impressed lug-handles attached to rim. Brick-red, core unoxidized, medium fine fabric, hand-modelled. No. So II 1294.
- V.82 Small bowl, lenticular, bevelled rim, exterior relieved with lotus pattern and festoons. Brick-red, core unoxidized, medium fine fabric, moulded. No. So II 1686.
- V.83 Small bowl, convex bottom, up-curved wall, beaked rim, exterior relieved with cordons of tetragons, rings and rosettes. Brick-red, fine fabric, moulded. No. So II 1735.
- V.84 Small bowl, hemispherical, concave foot, in-bevelled rim with groove below, exterior relieved with lotus pattern. Brick-red, red slipped, fine fabric, moulded. No. So II 1734.
- V.85 Small funnel-bowl, flat foot, flaring up-curved rim. Brick-red, fine fabric. No. So II 729.
- V.86 Funnel-bowl, carinated rim, protruding foot. Brick-red, core unoxidized, medium coarse fabric. No. So II 1494.
- V.87 Bowl-lid with central knob, angular sloping flange, flat bottom. Brick-red, medium fine fabric. No. So II 1562.
- V.88 Bowl-lid with central knob, double-beaded flange, flat bottom. Brick-red, interior red slipped, fine fabric. No. So II 1160.
- V.89 Bowl-lid with central knob, flange concave, knob conical. Ochre, smooth surface, fine fabric. No. So II 2106.
- V.90 Bowl-lid with jar-like grip-hole, shape of inverted cone, sloping flange. Buff, fine fabric. No. So II 2631.
- V.91 Bowl-lid with jar-like grip-hole, flat bottom, top of flange convex with inner edge. Light brick-red, interior red slipped, medium fine fabric. No. So II 1798.
- V.92 Bowl-lid with inward protruding folded flange, flat bottom. Brick-red, medium fine fabric. No. So II 1890.
- V.93 Lamp with solid capstan-shaped pedestal, funnel-shaped bowl, scalloped rim. Ochre, medium fabric, hand-modelled. No. So II 2558.
- V.94 Fragment of lamp with hollow pedestal, long loop-handle. Grey to ochre, fine fabric. No. So II 1861.
- V.95 Libation-vessel, globular, slender tube spout, lug-handle. Brick-red, fine fabric, hand-modelled. No. So II 1016.

V.96 Ring-stand, conical wall, bevelled lower rim, beaked upper rim, grooved, scratched symbols. Brick-red, core unoxidized, medium fine fabric. No. So II 2364.

V.97 Small ring-stand, reel-shaped. Reddish ochre, medium fine fabric. No. So II 2164.

V.98 Fragment of a pinnacle, conical corrugated head, constricted neck, deeply impressed arches on shoulder. Brick-red, red slip, core unoxidized, medium coarse fabric. No. So II 1676.

V.99 Fragmentary conical object, steep-walled, distinct throwing grooves inside. Brick-red, core grey, fine fabric. No. So II 2268.

Period VI. Pottery from Levels 15 to 12

VI.1 Bottle, ovoidal, long concave-sided neck with collar-rim. Brick-red, cream-coloured slip on neck, red slip on trunk, small hole in base of neck, fine fabric. No. So II 3094.

VI.2 Bottle-fragment, long slightly bulbous neck, banded rim. Brick-red, core unoxidized, red slip, medium fine fabric. No. So II 1577.

VI.3 Fragment of bottle(?), narrow long tapering neck with deeply profiled bulge. Light brick-red, red slipped smooth surface, medium fine fabric. No. So II 1323.

VI.4 Sprinkler, ovoidal, long concave-sided neck with disc-shaped top and conical mouth, wide pointed crop-spout with beaded rim. Brick-red, core unoxidized, smooth red slip on neck and shoulder, trunk daubed with micaceous slurry, medium fine fabric. No. So II 899.

VI.5 Small jar, lenticular, double-carinated, bottle-like narrow neck with thick beaked rim. Brick-red, fine fabric. No. So II 798.

VI.6 Fragment of big jar, presumably globular, short vertical neck, out-leaning banded collar-rim. Brick-red, neck and shoulder red slipped, below slurry-daubed, medium fine fabric. No. So II 647.

VI.7 Big jar, oblate globular, upcurved neck, banded rim, internally concave. Brick-red, red slip except below shoulder (perhaps indicating the position of a spout), medium fine fabric. No. So II 709.

VI.8 Big jar, globular, recurved neck, flaring rim with internal edge, externally grooved. Brick-red, smooth surface, dark red slip, horizontal black painted stripes, medium fine fabric. No. So II 541.

VI.9 Big jar, globular, wide and short recurved neck, flaring slightly drooping rim with internal edge. Brick-red, smooth surface, red slip, black painted stripes, medium fine fabric. No. So II 1062.

VI.10 Big jar, globular, angular out-curved neck, rim externally and internally grooved, under-cut, grooved and ridged below neck. Brick-red, smooth surface, red slip, three bands of horizontal black painted stripes, fine fabric. No. So II 841.

VI.11 Big jar, globular, angular out-curved neck with externally and internally grooved band-rim. Brick-red, smooth surface, red slip, horizontal black painted stripes, fine fabric. No. So II 1251.

VI.12 Jar, oblate globular, recurved neck, beaded rim, grooved on both sides. Brick-red, smooth surface, red slip, horizontal black stripes, fine fabric. No. So II 802.

VI.13 Jar, oblate globular, nearly vertical neck, angular everted and undercut rim. Brick-red, red slip, horizontal black painted stripes, fine fabric. No. So II 843.

VI.14 Jar-fragment, wide mouth, very short neck, thick curved rim, grooved and ridges underneath and inside. Dark brick-red, horizontal black painted stripes, fine fabric. No. So II 2206.

VI.15 Jar-fragment, bulbous trunk, gently recurved neck with broad collar-ledge, angular everted rim. Brick-red, smooth surface, red slip, horizontal black painted stripes, medium fabric. No. So II 958.

VI.16 Jar, wide-mouthed, bulbous, angular neck with thin collar-ledge, rim flaring, bevelled and everted, concave base with protruding edge. Brick-red, smooth red slip, groups of horizontal black painted stripes, fine fabric. No. So II 839.

VI.17 Jar, ovoidal, recurved neck above broad collar-ledge, flaring horizontal rim. Brick-red, smooth red slip, horizontal black painted stripes, medium fine fabric. No. So II 1162.

VI.18 Jar-fragment, globular, high shoulder, recurved neck with broad collar-ledge, bevelled undercut rim. Brick-red, core unoxidized, smooth red slip, medium fine fabric. No. So II 1237.

VI.19 Jar, heart-shaped profile, angular out-curved neck, channelled club-rim. Brick-red, core unoxidized, smooth surface, red slip, horizontal black painted stripes, medium fine fabric. No. So II 1125.

VI.20 Jar, flattened globular, flat bottom, concave neck, channelled and bevelled collar-rim. Brick-red, smooth surface, red slip, horizontal black painted stripes, fine fabric. No. So II 822.

VI.21 Jar, compact heart-shaped profile, concave bottom, steep funnel-neck, flaring everted rim, conical spout with pointed crop. Brick-red, smooth surface, red slip, horizontal black painted stripes, medium fine fabric. No. So II 846.

VI.22 Jar, globular, recurved neck, banded grooved collar-rim, bevelled inwards, slightly bulging ringed spout. Brick-red, neck and shoulder red slipped on smooth surface, below slurry-daubed, medium fine fabric. No. So II 1130.

VI.23 Jar, oblate globular, saggar-base, recurved neck, everted rim, ridge below neck, conical spout with beaded rim, paddled pellets & ridges pattern on upper half of trunk. Brick-red, smooth surface, rim and interior of neck red slipped, the paddled pattern washed with mica-slip, fine fabric. No. So II 970.

VI.24 Small jar, conical side, saggar-base, vertical neck, short corrugated oblique rim, conical spout. Light brick-red, medium fine fabric. No. So II 1240.

VI.25 Double-spout of a jar. Brick-red, daubed with micaceous slurry, fine fabric. No. So II 1409.

VI.26 Small jar, ovoidal, funnel-neck with flaring rim, flat bottom, pointed crop-spout. Brick-red, red slipped, interior of neck and rim gold-slipped, fine fabric. No. So II 925.

VI.27 Jar, heart-shaped in section, conical neck, flaring deeply grooved rim, spout missing. Brick-red, red slipped smooth surface, interior of neck and rim gold-slipped, fine fabric. No. So II 943.

VI.28 Jar-fragment, globular, narrow neck, bowl-shaped bevelled rim. Brick-red, daubed with micaceous slurry from shoulder downwards, fine fabric. No. So II 135.

- VI.29 Jar, wheel-shaped with inwards sloping shoulder (saddle-shoulder), very short neck, flaring undercut rim, short crop-spout, saggar-base. Brick-red, belly decorated with dabs of slurry, shoulder, neck and rim red slipped, partly gold-painted, fine fabric. No. So II 946.
- VI.30 Jar, lenticular, steep funnel-neck, short undercut band-rim with groove on top. Brick-red, core unoxidized, black painted stripes, lobed bands and swans, medium fine fabric. No. So II 1205.
- VI.31 Jar, lenticular, angular flaring rim. Brick-red, red slip, black painted lobed necklace, fine fabric. No. So II 971.
- VI.32 Jar, heart-shaped in section, flat bottom, out-curved neck, band-rim concave with S-curved notches. Brick-red, smooth surface, red slip, fine fabric. No. So II 434.
- VI.33 Jar, pyriform, recurved neck with small ridge, sharp-edged bevelled rim. Brick-red, fine fabric. No. So II 982.
- VI.34 Jar, globular, steep funnel-neck, short drooping rim, base of neck grooved. Brick-red, smooth surface, red slip, medium fine fabric. No. So II 940.
- VI.35 Jar, lenticular, steep tapering neck, thick banded rim, grooves and impressed curved notches on shoulder, groups of impressed concentric circles on rim and belly. Brick-red, smooth surface, red slip, fine fabric. No. So II 937.
- VI.36 Small jar, oblate globular trunk, flat foot, wide neck, flaring bevelled rim, grooved belly. Light brick-red, red slip, medium fine fabric. No. So II 1202.
- VI.37 Small jar, double-bulging, flat bottom, short recurved neck, band-rim. Brick-red, core unoxidized, medium fabric. No. So II 1080.
- VI.38 Small carinated jar, flat foot, conical shoulder, bulging lower trunk, flaring rim. Brick-red, red slip, fine fabric. No. So II 628.
- VI.39 Small jar, squat bulbous, saggar-base, recurved short neck, thick rim grooved on top and outside, groove on shoulder. Brick-red, core unoxidized, red slip, medium fine fabric. No. So II 1241.
- VI.40 Small jar, globular, narrow neck, flaring bevelled rim, flat foot. Brick-red, medium fine fabric, No. So II 2090.
- VI.41 Small lenticular jar, flat base, steep funnel-neck, everted beaded rim. Brick-red, fine fabric. No. So II 818.
- VI.42 Small jar, lenticular, narrow distinct foot, neckless. Dark grey, fine fabric. No. So II 400.
- VI.43 Pitcher, pyriform, out-curved neck, bevelled rim, finger-drawn open spout (pouring lip), flattened bottom. Brick-red, red slipped, fine fabric. No. So II 387.
- VI.44 Cooking vessel, carinated, lenticular lower trunk, long conical shoulder, up-curved neck with grooves and ridges, angular flaring rim grooved on top. Brick-red, shoulder and rim red slipped, medium fine fabric. No. So II 868.
- VI.45 Cooking vessel, slightly bulging lower trunk, small carination ledge, conical shoulder, grooved, angular steep beaded rim. Brick-red, red slip, medium fine fabric. No. So II 989.
- VI.46 Cooking vessel, carinated, angular flaring rim, slightly curved down, grooved on top. Brick-red, core unoxidized, red slip, black painted horizontal stripes, medium fine fabric. No. So II 1285.
- VI.47 Cooking vessel, carinated, out-curved rim. Brick-red, core unoxidized, smooth red slip, medium fine fabric. No. So II 1442.
- VI.48 Cooking vessel, lenticular, without carination, angular flaring rim, grooved on top. Brick-red, red slip, black painted horizontal stripes, fine fabric. No. So II 823.
- VI.49 Cooking vessel, globular, angular rim, carination very low. Light brick-red, smooth surface, red slip above carination, medium fine fabric. No. So II 1096.
- VI.50 Cooking vessel, bulging lower trunk, pronounced up-turned carination, concave shoulder, angular everted double-edged rim, shoulder grooved. Brick-red, shoulder and rim smooth, red slipped, lower trunk slurry-daubed, medium fine fabric. No. So II 857.
- VI.51 Cooking vessel, wide mouth, carinated, lower trunk lenticular, conical shoulder, angular flaring rim, shoulder and rim grooved. Brick-red, red slip, fine fabric. No. So II 811.
- VI.52 Cooking vessel, lenticular lower trunk, up-turned carination, conical shoulder, angular flaring and down-curved double-edged and grooved rim. Ochre, core grey, red slipped rim and shoulder, interior of bottom micaceous, fine fabric. No. So II 2126.
- VI.53 Cooking vessel, nearly globular, up-turned carination ridge, angular funnel-rim with drooping edge, partly scalloped. Brick-red, shoulder and rim smooth, red slipped, lower trunk slurry-daubed, medium fine fabric. No. So II 1193.
- VI.54 Bowl with bulging wall, sharply angular flaring and drooping rim, concave bottom. Brick-red, smooth red slipped surface, black painted horizontal stripes on trunk, other painted ornaments on rim, fine fabric. No. So II 587.
- VI.55 Hemispherical bowl, horizontal flange with sharp inner edge and stepped off rim. Brick-red, interior red slipped on smooth surface, exterior slurry-daubed, medium fine fabric. No. So II 1073.
- VI.56 Large bowl, lenticular bottom, banded rim. Brick-red, smooth red slipped surface, fine fabric. No. So II 1208.
- VI.57 Heavy bowl, flat base, funnel-wall, bevelled rim, ridge below rim. Brick-red, interior and rim red slipped, medium fine fabric. No. So II 984.
- VI.58 Heavy bowl, flat base, funnel-wall, thick concave banded rim. Brick-red, medium fine fabric. No. So II 767.
- VI.59 Heavy bowl, flat base, slightly bulging funnel-wall, broad beaded rim. Brick-red, interior red slipped, traces of black paint, medium fine fabric. No. So II 807.
- VI.60 Shallow funnel-bowl with stepped-up flange, flat base. Brick-red, interior red slipped, fine fabric. No. So II 1072.
- VI.61 Large dish, carinated out-leaning wall, bevelled rim, flat bottom. Brick-red, red slip, medium fine fabric. No. So II 794.
- VI.62 Large bowl, carinated, lenticular bottom, concave upper trunk, stepped rim with sharp inner edge, two lug-handles attached to rim. Light brick-red, core unoxidized, bottom slurry-daubed, medium coarse fabric. No. So II 1134.
- VI.63 Dish or shallow bowl, flat bottom, slightly concave out-leaning wall, flat-topped double-edged rim with groove and impressed cuneiform dots, incised rosette in centre. Brick-red, core unoxidized, red slip, medium fine fabric. No. So II 523.

VI.64 Cauldron, hemispherical with slightly constricted double-beaded (nail-head) rim. Brick-red, coarse fabric, hand-built. No. So II 533.

VI.65 Small funnel-bowl, flat foot, plain rim. Light brick-red, fine fabric. No. So II 717.

VI.66 Small funnel-bowl, pronounced flat foot, up- and in-curved rim with internal edge. Brick-red, fine fabric. No. So II 896.

VI.67 Small funnel-bowl, flat foot, up-curved tapering plain rim. Brick-red, fine fabric. No. So II 649.

VI.68 Small bowl, flat foot, out-leaning wall, thick undercut club-rim. Brick-red, fine fabric. No. So II 766.

VI.69 Small dish, pronounced flat foot, thick short up-curved wall, banded corrugated rim. Brick-red, medium fine fabric. No. So II 1112.

VI.70 Carinated cup, pronounced flat foot, concave wall, flaring bevelled rim. Brick-red, red slip, medium fine fabric. No. So II 1182.

VI.71 Cup, bulging wall, pronounced flat foot, bevelled funnel-rim. Brick-red, core unoxidized, medium coarse fabric. No. So II 1094.

VI.72 Cup, flat foot, out-leaning lower wall, vertical upper wall, bevelled rim. Brick-red, fine fabric. No. So II 1045.

VI.73 Goblet, bell-shaped, pronounced carination, protruding flat foot, bevelled rim. Brick-red, medium fine fabric. No. So II 855.

VI.74 Cup, bell-shaped, pronounced carination, flat base, everted and drooping tapering rim. Brick-red, rim and upper wall red slipped, fine fabric. No. So II 854.

VI.75 Moulded cup with out-leaning wall, convex bottom, circular ridge between wall and bottom, vertical tapering ridges, The whole cup representing a lotus flower. Brick-red, core unoxidized, dark brown slip, fine fabric. No. So II 1114.

VI.76 Moulded bowl, flat bottom, up-curved wall, plain rim, the relief ornament consisting of a circular dotted band around the base, angular dotted bands and small circular groups of dots on the wall. Brick-red, red slip, fine fabric. No. So II 1107.

VI.77 Small bowl, lenticular bottom, up-curved wall, thick rim with circa twenty-eight grooved buttons attached to it. Brick-red, red slip, fine fabric, hand-modelled. No. So II 538.

VI.78 Moulded goblet, wide tulip-shaped bowl with cylindrical solid stem and hollow conical foot. Brick-red, smooth red slip, relief-ornaments (lotus, ridges), fine fabric. No. So II 599

VI.79 Moulded bowl with nearly flat bottom and up-curving wall. Brick-red, relief-ornaments (rosettes, circle of pellets, and ridge around base), medium fine fabric. No. So II 1536.

VI 80 Bowl-lid with central knob, flat foot, up-turned edge of flange. Brick-red, interior red slipped, fine fabric. No. So II 738.

VI.81 Bowl-lid with central knob, flat base, grooved flange with sharp inner edge. Brick-red, red slip, traces of black paint(?), medium fine fabric. No. So II 759.

VI.82 Bowl-lid with in-beaded flange, concave base. Brick-red, fine fabric. No. So II 669.

VI.83 Bell-shaped lid, carinated, beaded rim, flat knob. Brick-red, red slip, fine fabric. No. So II 686.

VI.84 Bell-shaped lid with hollow lantern-knob, hemispherical, grooved. Brick-red, red slip, fine fabric. No. So II 809.

VI.85 Stopper with flat base, sloping flange and central cavity. Brick-red, fine fabric. No. So II 624.

VI.86 Pedestal-lamp with loop-handle, scalloped drooping rim. Brick-red, smooth red slip, fine fabric. No. So II 1101.

VI.87 Small spouted vessel (libation-jarlet), concave foot, relief-ornament consisting of mica-painted pellets and ridges. Brick-red, medium fine fabric, hand-modelled. No. So II 1017.

VI.88 Bell-shaped object with wavy stem, without bottom. Ochre, red slip, medium coarse fabric. No. So II 1593.

VI.89 "Funnel-cum-bowl", i.e. two bowl-shapes combined. Light brick-red, outer rim slightly micaceous, inner funnel gold-painted, medium fine fabric. No. So II 1268.

Period VII. Pottery from Levels 12 to 8

VII.1 Globular bottle, short neck, tapering corrugated rim, trunk decorated with cordons of grooves and notches. Grey, black slip, medium fine fabric. No. So II 905.

VII.2 Globular jar, nearly cylindrical neck, separated from trunk by small ridge, band-rim with groove. Brick-red, red slip, horizontal black painted stripes, fine fabric. No. So II 596.

VII.3 Globular jar, cylindrical neck, beaked and grooved rim, conical spout. Ochre, red slipped except at the level of the spout, medium fine fabric. No. So II 359.

VII.4 Big globular jar, concave neck, deeply channelled rim. Brick-red, very smooth red slipped surface, in dry state scratched geometric and flower ornaments, fine fabric. No. So II 437.

VII.5 Globular jar, wide conical neck, angular flaring rim. Brick-red, red slipped, black painted stripes, lobed band, wave-line, fine fabric. No. So II 507.

VII.6 Globular jar, conical neck, angular band-rim. Brick-red, red slip, black painted stripes, cross-hatch band, festoons and lobed band on trunk and rim, medium fine fabric. No. So II 934.

VII.7 Globular jar, concave neck, band-rim with groove. Brick-red, neck and shoulder black slipped, middle part decorated with multiple arches of slurry, medium fine fabric. No. So II 588.

VII.8 Cooking vessel, carinated, lenticular bottom, angular flaring rim, grooved on top. Light brick-red, smooth red slip, medium fine fabric. No. So II 869.

VII.9 Cooking vessel, bulging trunk, small carination ridge, steep angular neck, beaded rim. Light brick-red, smooth red slip, medium fine fabric. No. So II 851.

VII.10 Cooking vessel, lenticular bottom, nearly vertical wall, up-turned shoulder-ridge, angular everted and drooping rim with notched and eared strap attached to it. Brick-red, red slip, slurry-daubed, medium fine fabric. No. So II 512.

VII.11 Cooking vessel (bowl), carinated, lenticular bottom, concave upper trunk, stepped rim, eared lug-handle attached to it. Brick-red, red slip, fine fabric. No. So II 430.

VII.12 Cooking vessel, sloping wall, lenticular bottom, up-turned ridge halfway up, angular everted and drooping rim with

notched and eared strap attached. Brick-red, red slip, fine fabric. No. So II 421.

VII.13 Cooking vessel, carinated, thick beaded rim. Brick-red, red slip, fine fabric. No. So II 1040.

VII.14 Carinated jar, bulging wall, lenticular bottom, concave grooved and ridged shoulder, cylindrical neck, angular flaring rim with undercut banded edge. Grey, fine fabric. No. So II 579.

VII.15 Small carinated jar, lenticular bottom, grooved conical shoulder, out-curved neck, flaring beak-rim. Brick-red, red slip, medium fine fabric. No. So II 1297.

VII.16 Small bulging jar, flat base, concave neck, beaked rim. Brick-red, red slip, medium fine fabric. No. So II 383.

VII.17 Small carinated jar, biconical, flat foot, in-bevelled rim. Ochre, red slip, fine fabric. No. So II 367.

VII.18 Small double-carinated jar, biconical cylindrical middle part, cylindrical neck, everted beaded rim. Brick-red, red slip except at bottom, medium fine fabric. No. So II 368.

VII.19 Small spouted jar, carinated wall, saggar-base, steep funnel-neck, bevelled rim, conical spout. Brick-red, black painted double arches, fine fabric. No. So II 356.

VII.20 Small jar, lenticular bottom, short vertical wall, conical shoulder, steep funnel-neck, long banded rim with sharp inner edge. Brick-red, red slip, black painted lobed band, cross-hatch band and wave band on neck and trunk, fine fabric. No. So II 931.

VII.21 Small spouted jar, globular, flat foot, out-curved rim, thick conical spout. Brick-red, upper half red slipped, belly grooved, medium fine fabric. No. So II 45.

VII.22 Fragment of a globular vessel with animal-spout. Brick-red, red slip, fine fabric. No. So II 1320.

VII.23 Bulbous jarlet, flat foot, long concave neck, bevelled rim. Ochre, medium fine fabric. No. So II 2069.

VII.24 Small carinated bowl, restricted neck, bevelled funnel-rim, flat base. Brick-red, fine fabric. No. So II 621.

VII.25 Small bowl, bulging wall, lenticular bottom, restricted neck, angular flaring rim. Brick-red, red slip, black painted interlocking double arches, fine fabric. No. So II 1057.

VII.26 Carinated bowl, out-curving wall, banded rim, flat cylindrical foot. Ochre, black painted interlocking festoons inside rim, circle in the well, fine fabric. No. So II 315.

VII.27 Small bowl, lower part flaring, upper part cylindrical, flat foot, plain rim. Brick-red, fine fabric. No. So II 689.

VII.28 Small funnel-bowl, flat base, bevelled rim. Brick-red, medium fine fabric. No. So II 1002.

VII.29 Hemispherical bowl, plain rim, flat foot. Brick-red, core unoxidized, fine fabric. No. So II 969.

VII.30 Small bowl, up-curved wall, concave bottom, slightly concave upper wall, flat-topped rim. Brick-red, fine fabric. No. So II 694.

VII.31 Dish, convex bottom with flat centre, flaring in-beaded rim. Brick-red, red slip, fine fabric. No. So II 429.

VII.32 Bowl with curved wall, slightly clubbed rim, protruding footring. Brick-red, red slip, black painted border (double festoons), floral pattern in well, fine fabric. No. So II 50.

VII.33 Large basin, flaring wall, flat base, finger-dented strip applied to ridge below rim. Reddish ochre, red slip, core unoxidized, medium fine fabric. No. So II 534.

VII.34 Bell-shaped lid with hollow lantern knob. Brick-red, smooth red slip, black painted ornaments, fine fabric. No. So II 1058.

VII.35 Bell-shaped lid with flat knob. Ochre, red slipped, medium fine fabric. No. So II 1509.

VII.36 Shallow bell-shaped lid with flat knob. Brick-red, medium fine fabric. No. So II 56.

VII.37 Bowl-lid with hollow conical knob. Light brick-red, medium fine fabric. No. So II 53.

VII.38 Fragment of a pedestal-lamp with loop-handle, perforated wall. Brick-red, fine fabric. No. So II 2362.

Period VIII. Pottery from Levels 7 to 1

VIII.1 Globular jar, steep funnel-neck, banded rim. Brick-red, red slip, black painted ornaments, fine fabric. No. So II 511.

VIII.2 Big globular jar, wide mouth, short conical neck, angular banded funnel-rim. Brick-red, black and white painted ornaments, fine fabric. No. So II 347.

VIII.3 Globular jar, nearly cylindrical neck, ringed rim, conical spout. Brick-red, red slip, black painted ornaments, medium fine fabric. No. So II 552.

VIII.4 Carinated jar, bulging lower trunk, convex bottom, conical long shoulder, funnel-neck, bevelled rim. Brick-red, red slip, black painted decoration, fine fabric. No. So II 871.

VIII.5 Cooking vessel, bulging wall, slightly carinated, out-curved rim. Light brick-red, red slip, black and white painted ornaments, fine fabric. No. So II 299.

VIII.6 Cooking vessel, bulging wall, slightly carinated shoulder, steep angular everted funnel rim. Brick-red, red slip, bottom rough with grit and chaff, fine fabric. No. So II 519.

VIII.7 Bowl with flat foot, flaring wall, angular up-turned rim. Brick-red, smooth dark red slip inside, black painted ornaments inside rim and in wall, fine fabric. No. So II 376.

VIII.8 Hemispherical bowl with footring, thin beaded rim. Brick-red, polished red slip, exterior grooved and rouletted (before slipping), fine fabric. No. So II 537.

VIII.9 Bowl, flat base, flaring wall, concave interior, horizontal angular flange with banded edge. Brick-red, fine fabric. No. So II 522.

VIII.10 Deep basin, flat base, funnel-wall, slightly up-curved beaked rim. Light brick-red, core unoxidized, smooth red slip, medium fine fabric. No. So II 1505.

VIII.11 Fragment of dome-shaped lid with profiled knob. Grey, light grey slip, spiral groove all over, fine fabric. No. So II 101.

VIII.12 Conical lid with flat-topped knob, up-turned beaded rim. Brick-red, interior and rim red slipped, fine fabric. No. So II 428.

VIII.13 Globular hookah-bottle with collar-neck, steep funnel-rim, narrow flat space at bottom. Grey, burnished surface with incised floral and architectural ornaments, the background filled in with white slip, moulded, very fine fabric. No. So II 1115.

VIII.14 Globular hookah-bottle with collar-neck, steep funnel-rim. Brick-red, very smooth red slip over relief ornaments, moulded, very fine fabric. No. So II 1082.

VIII.15 Hookah-bottle, vertical wall, conical shoulder, saggar-base with protruding edge, steep funnel-neck with ledge, bevelled rim, ridge and grooves at base of neck. Brick-red, fine fabric. No. So II 169.

VIII.16 Hookah-bottle, ovoidal trunk, protruding flat foot, tapering neck with ledge, tubular spout, channel of neck projecting inwards. Brick-red, medium fine fabric. No. So II 144.

VIII.17 Hookah-bowl, globular with tapering stem, base of rim (neck) constricted, bevelled rim. Brick-red, fine fabric. No. So II 336.





I.1



I.2



I.3

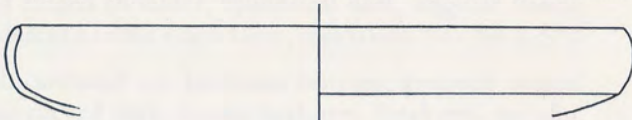

I.4



I.5

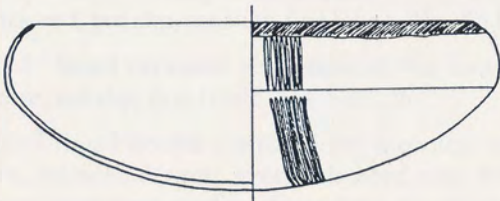

I.6



I.7

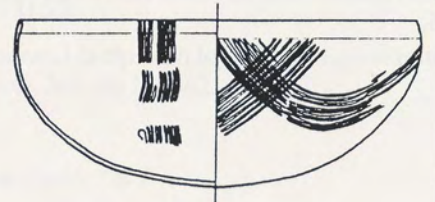

I.8



I.9

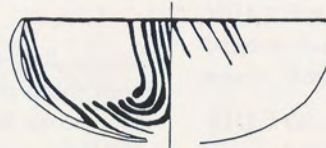

I.10

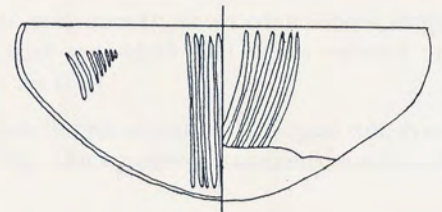

I.11

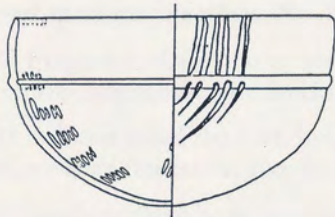

I.12

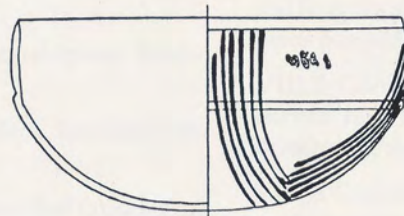

I.13

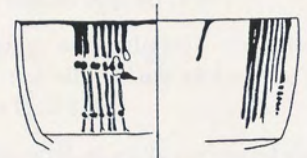

I.14

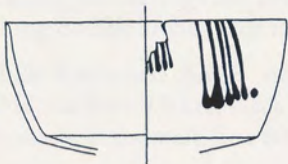

I.15

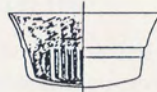

I.16



I.17

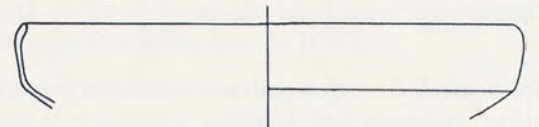

I.18

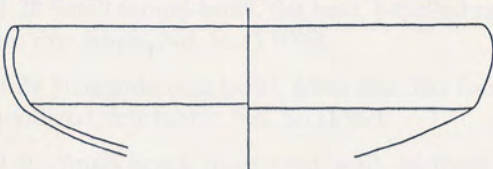

I.19

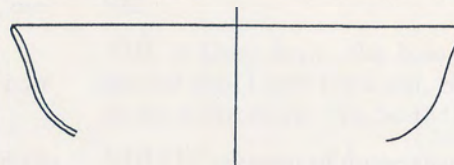

I.20

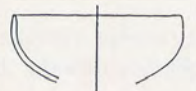

I.21

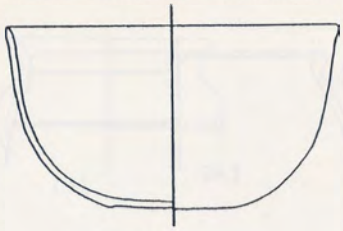

I.22

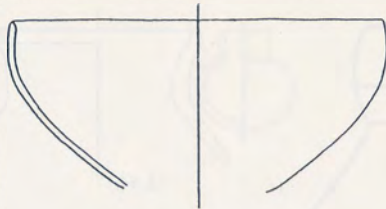

I.23

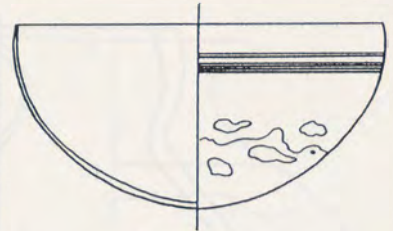

I.24

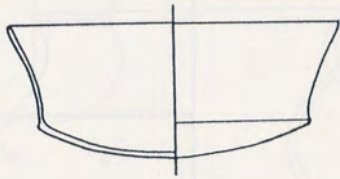

I.25

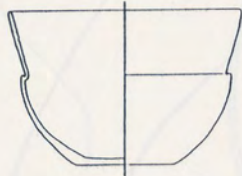

I.26



I.27

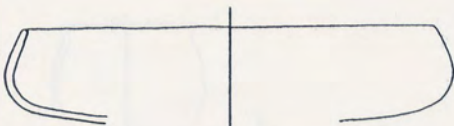

I.28

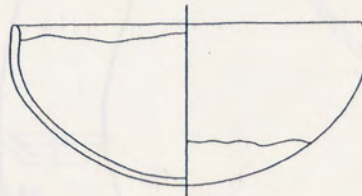

I.29

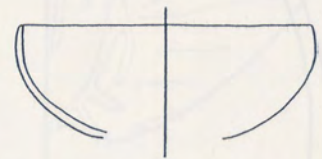

I.30

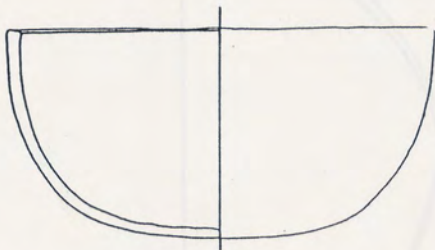

I.31

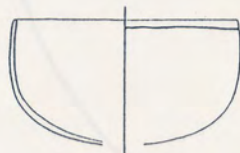

I.32

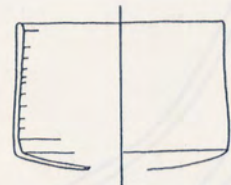

I.33



I.34

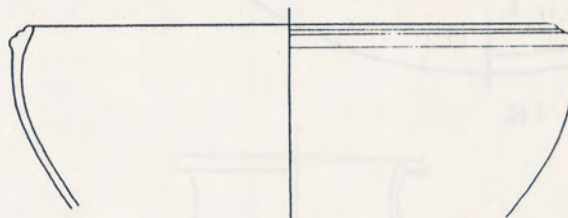

I.36

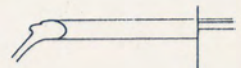

I.37

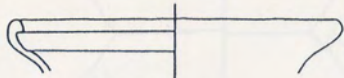

I.35



I.38

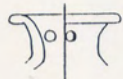

I.39

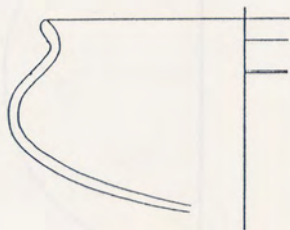

I.42

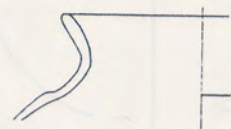

I.43

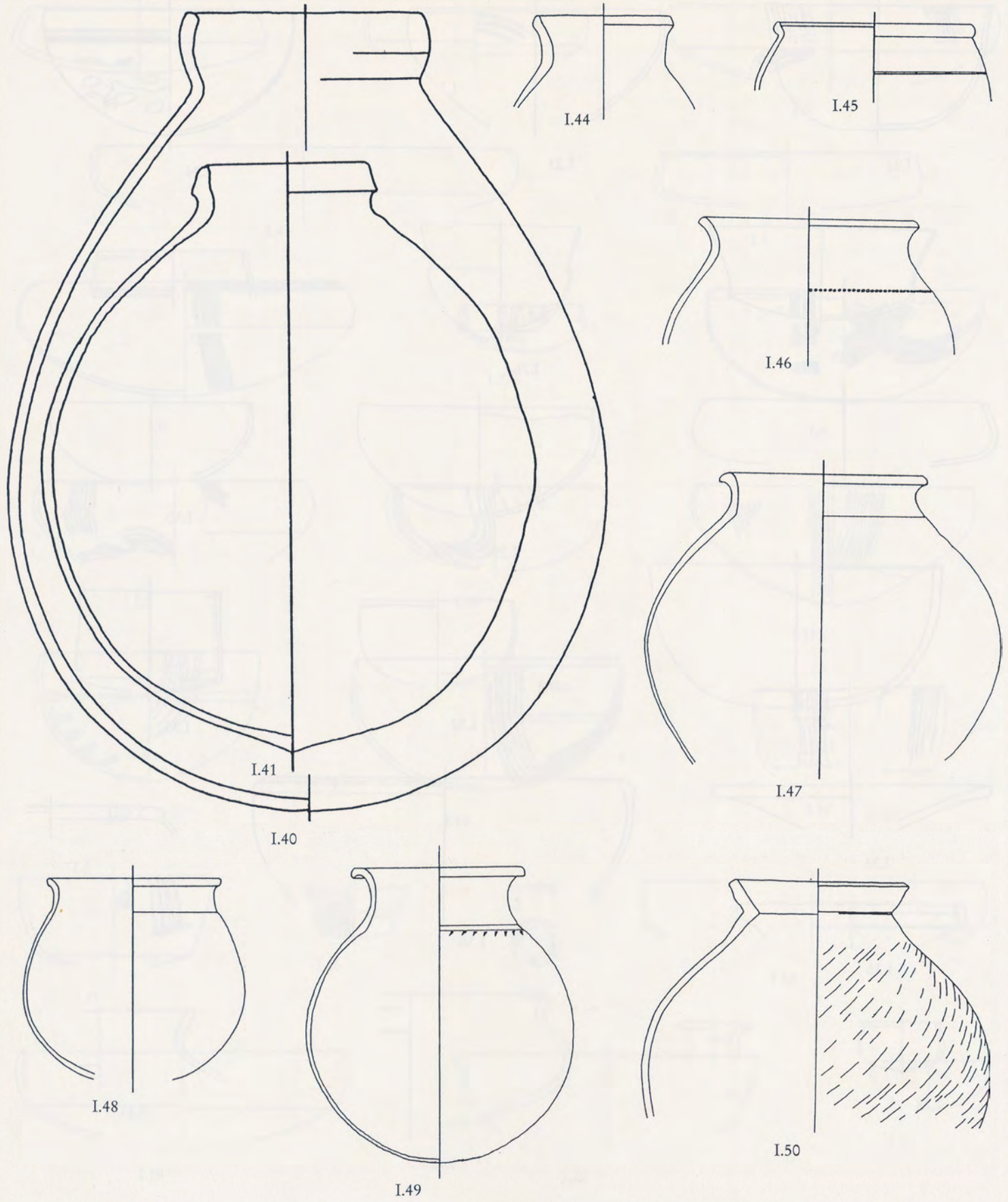

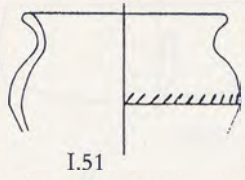

I.51

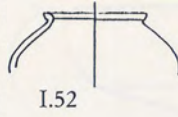

I.52

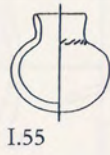

I.55

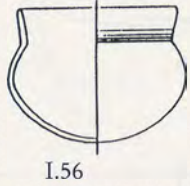

I.56

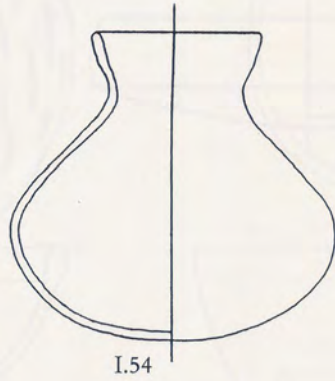

I.54



I.57

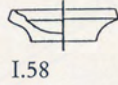

I.58

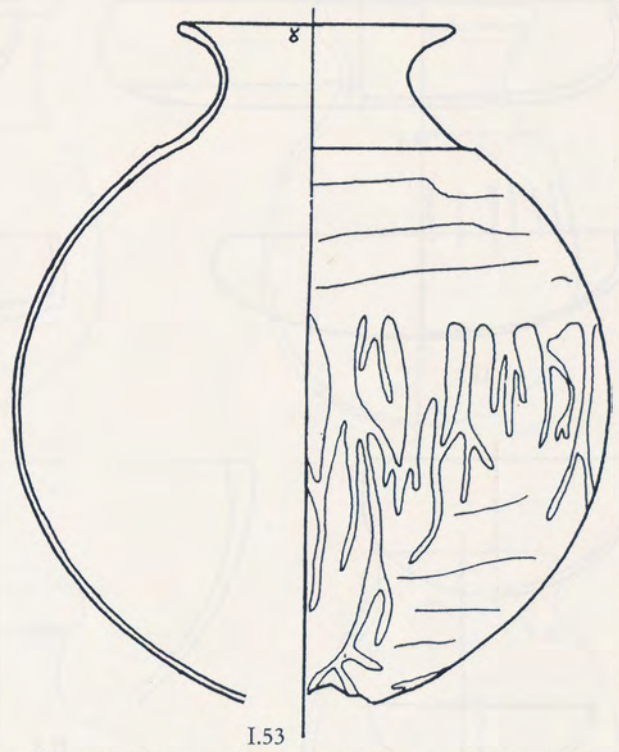

I.53

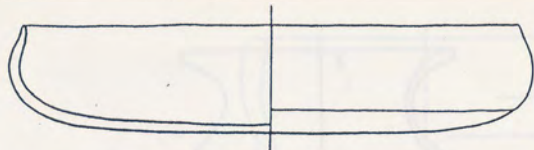

II.1

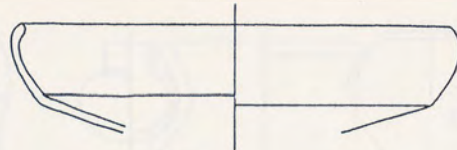

II.2

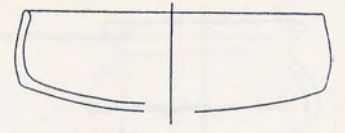

II.5



II.3



II.4

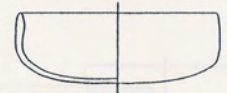

II.6



II.7



II.8

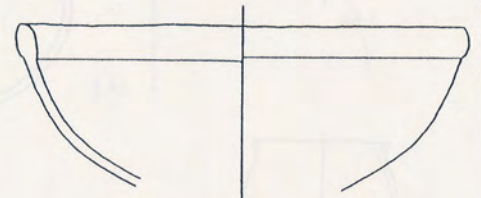

II.9



II.10

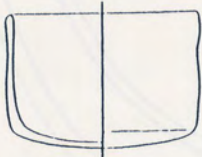

II.11

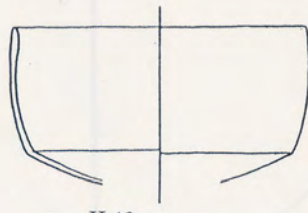

II.12

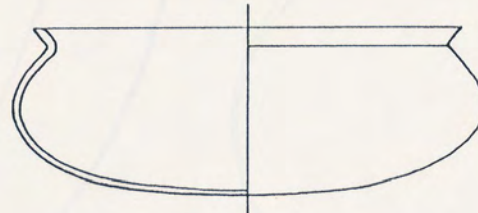

II.14

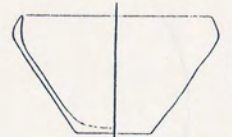

II.13

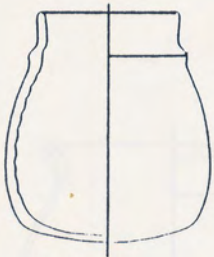

II.18

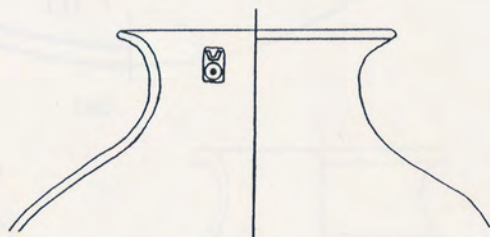

II.16



II.15



II.17

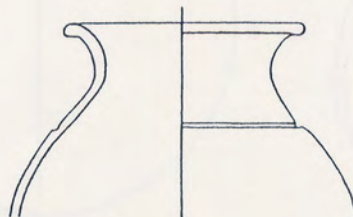

II.19



II.25

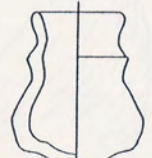

II.26

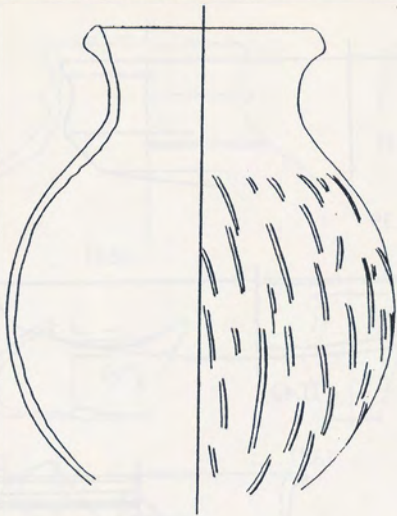

II.20

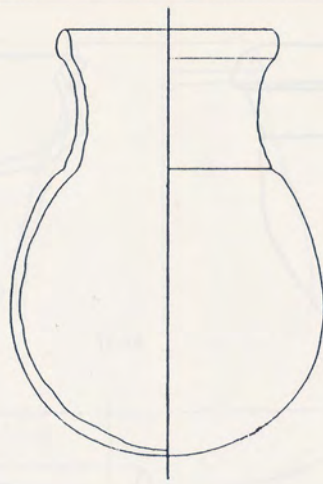

II.21

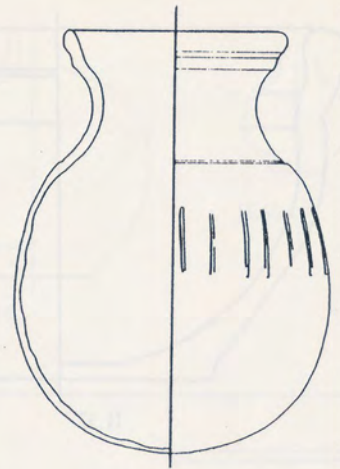

II.22

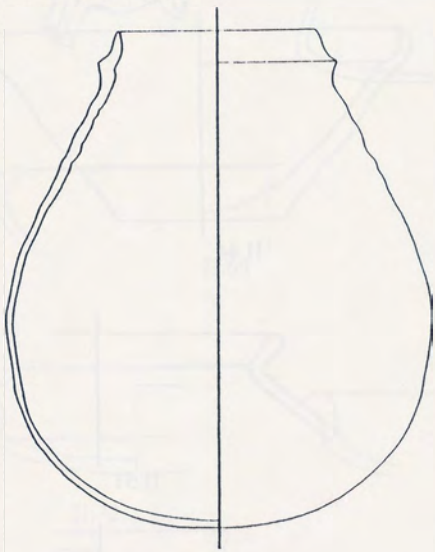

II.23

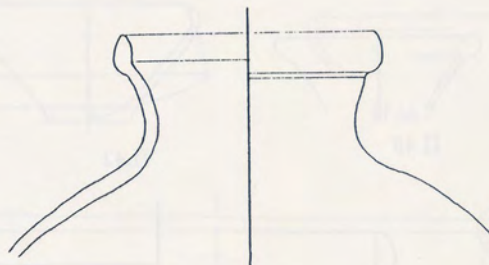

II.29

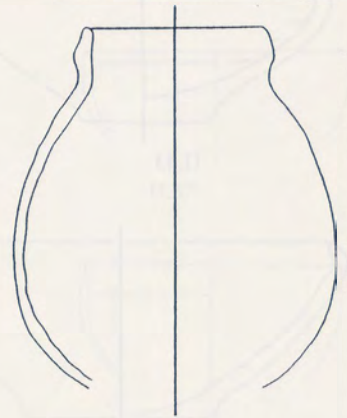

II.24

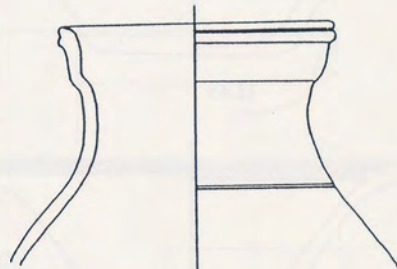

II.27

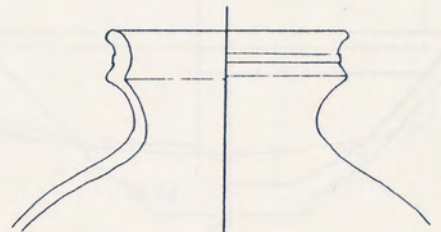

II.28

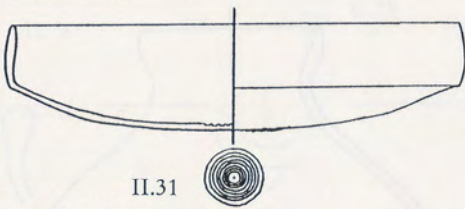

II.31

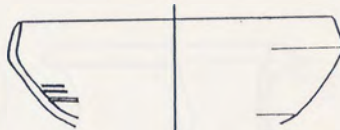

II.34

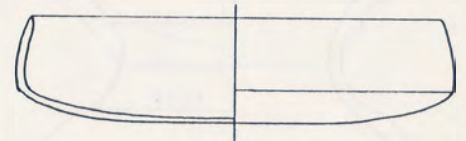

II.30

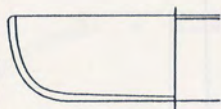

II.32

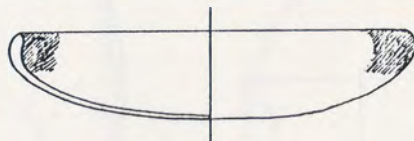

II.33

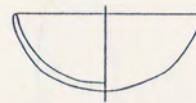

II.35



II.36

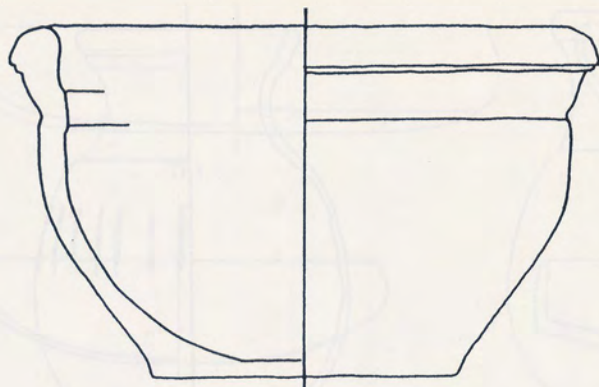

II.37

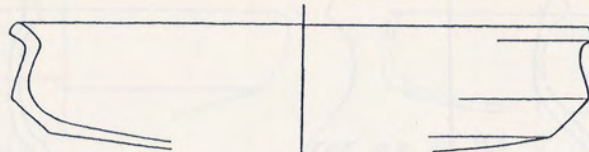

II.39

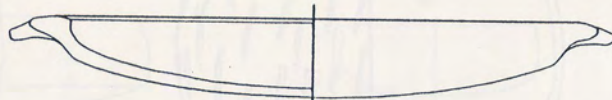

II.40

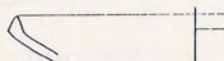

II.41

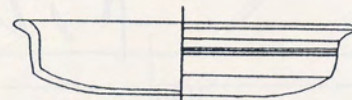

II.38

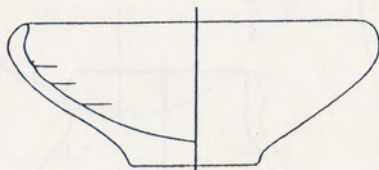

II.43



II.48

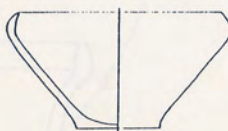

II.42

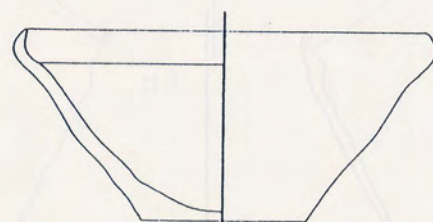

II.44

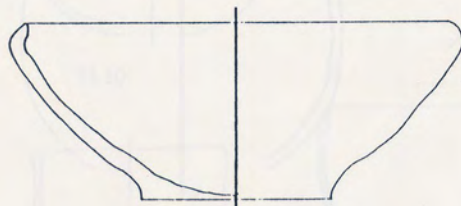

II.46

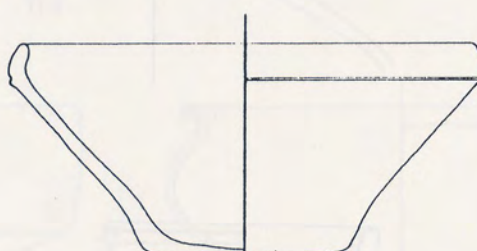

II.45

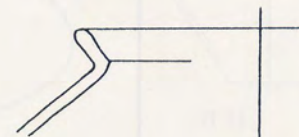

II.51



II.47

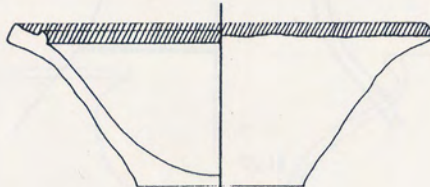

II.49

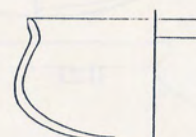

II.50

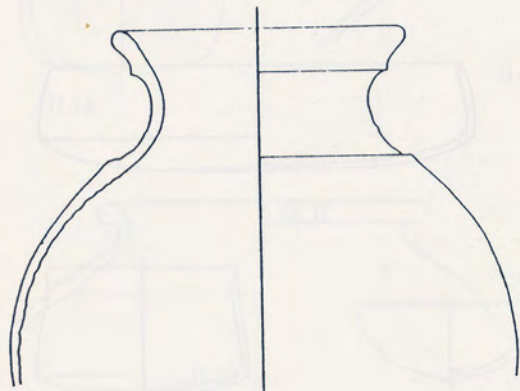

II.55

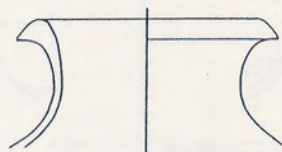

II.52



II.53

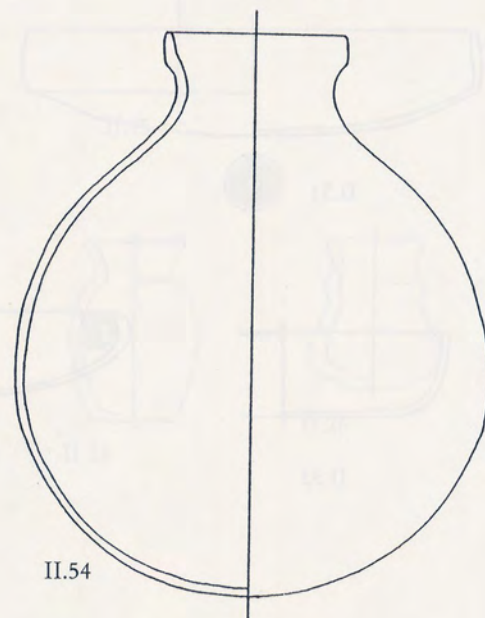

II.54

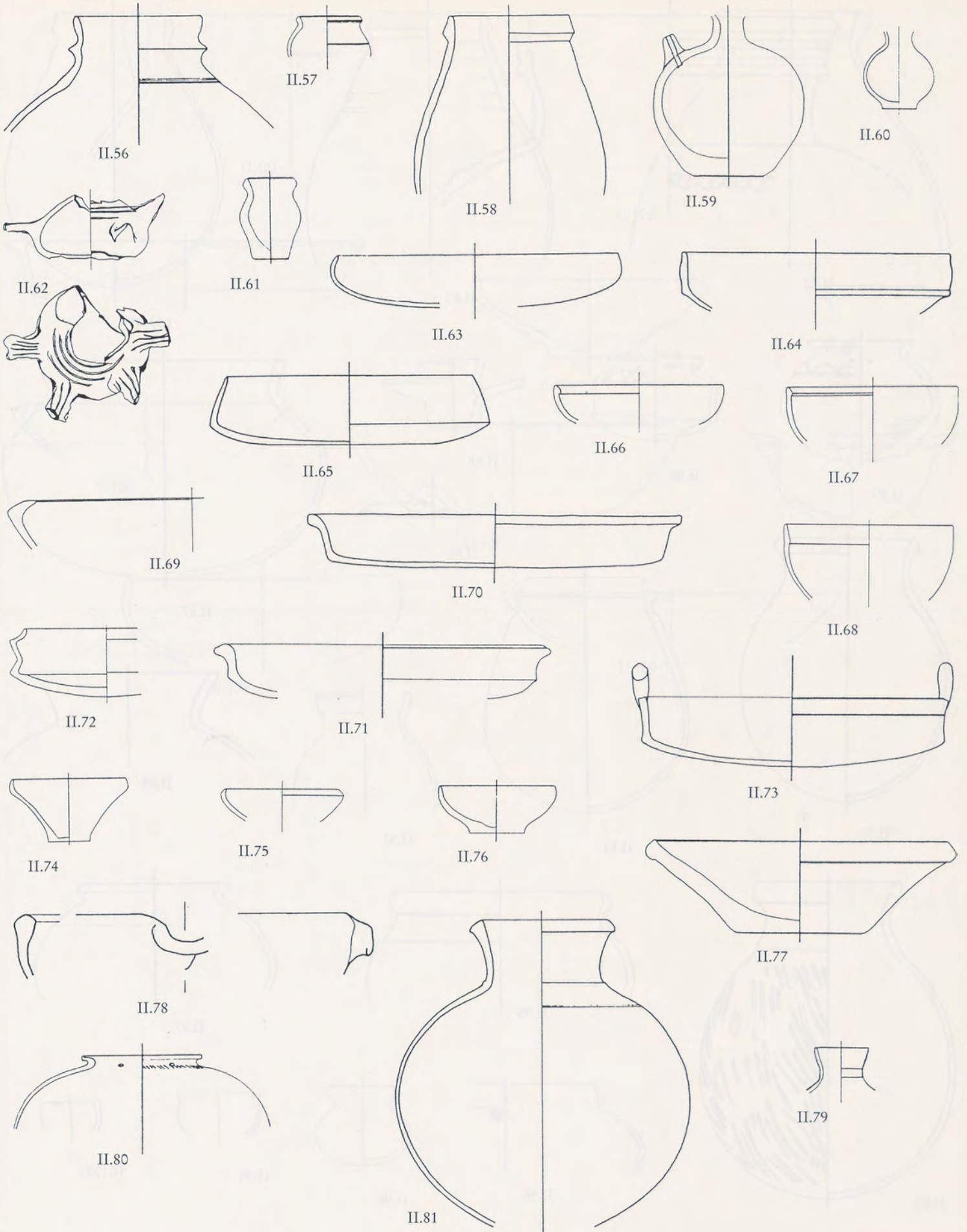

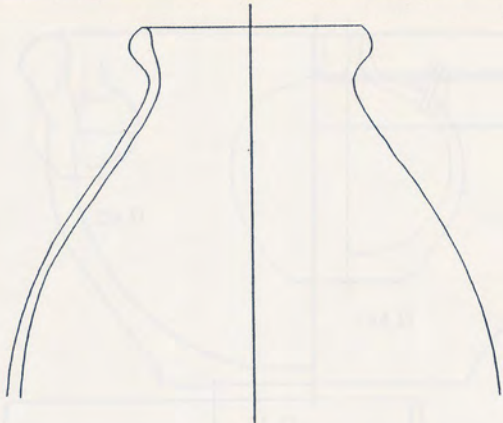

II.82

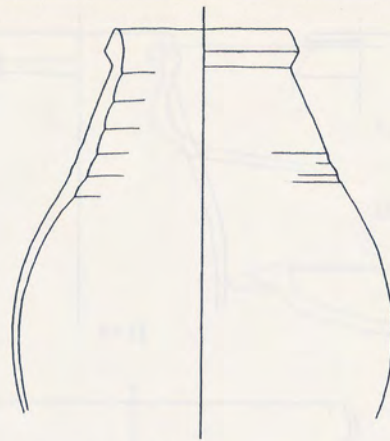

II.83

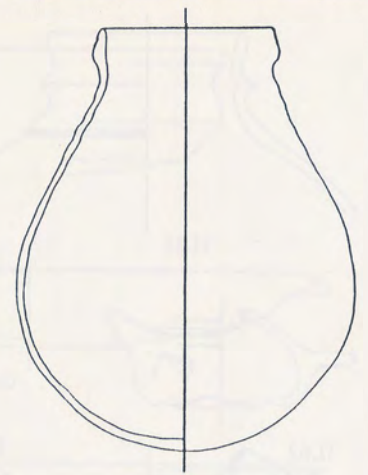

II.84

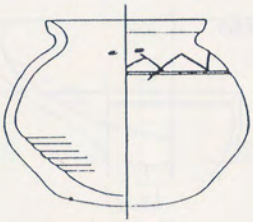

II.85

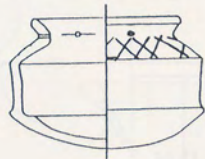

II.86

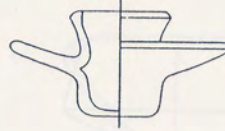

II.88



II.89

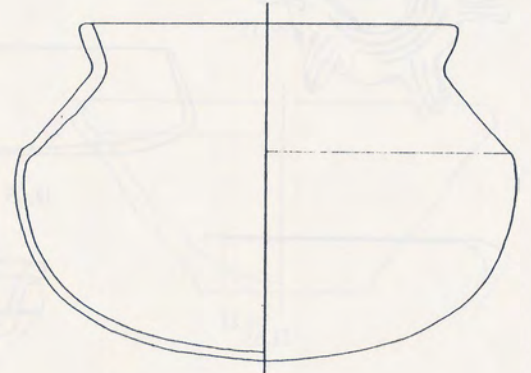

II.87

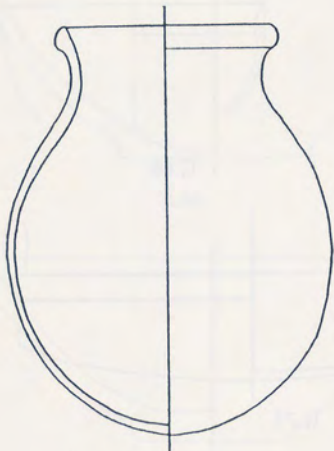

II.90

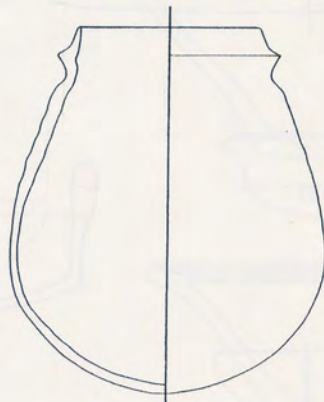

II.91

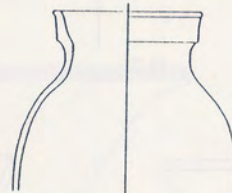

II.93

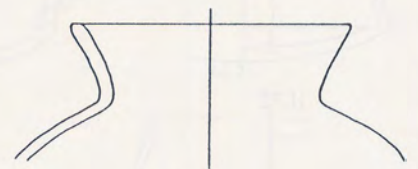

II.94

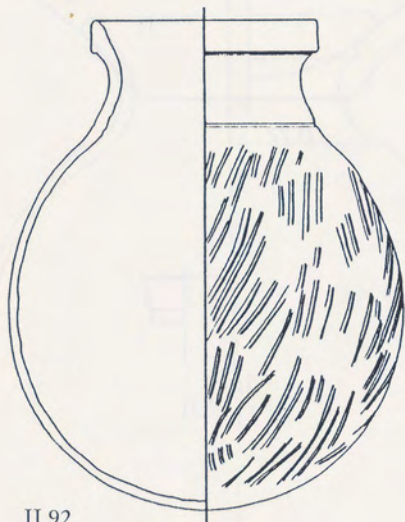

II.92

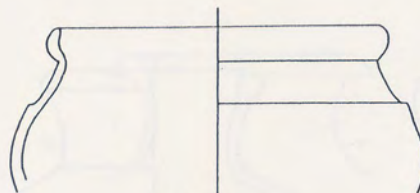

II.95

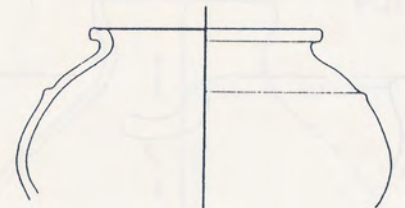

II.97

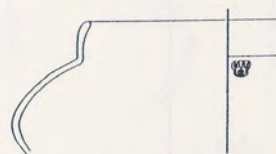

II.96

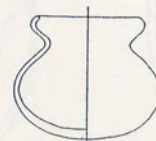

II.98



II.99



II.100

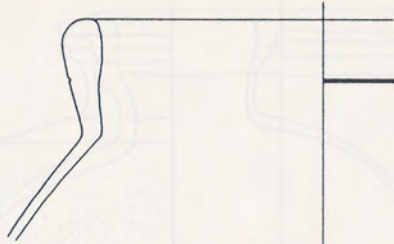

II.101

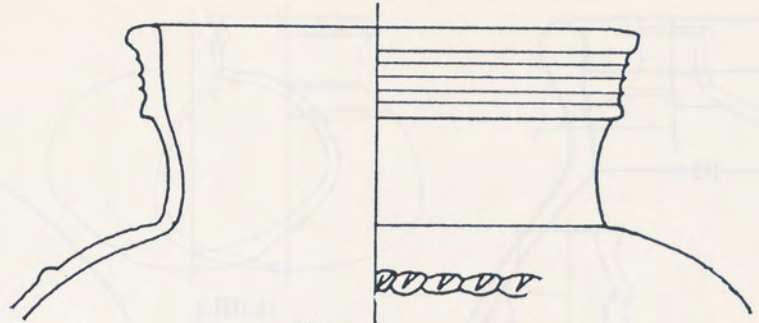

II.102

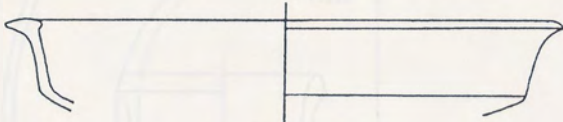

II.103

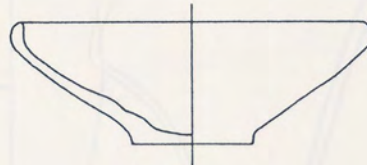

II.104

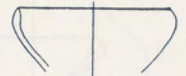

II.105



II.106

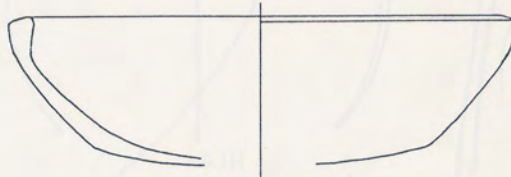

II.107

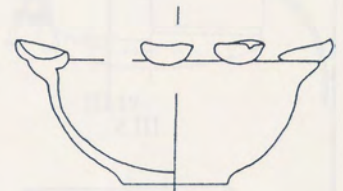

II.110

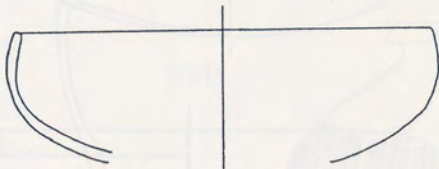

II.108

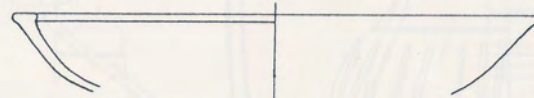

II.109

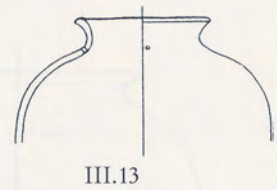
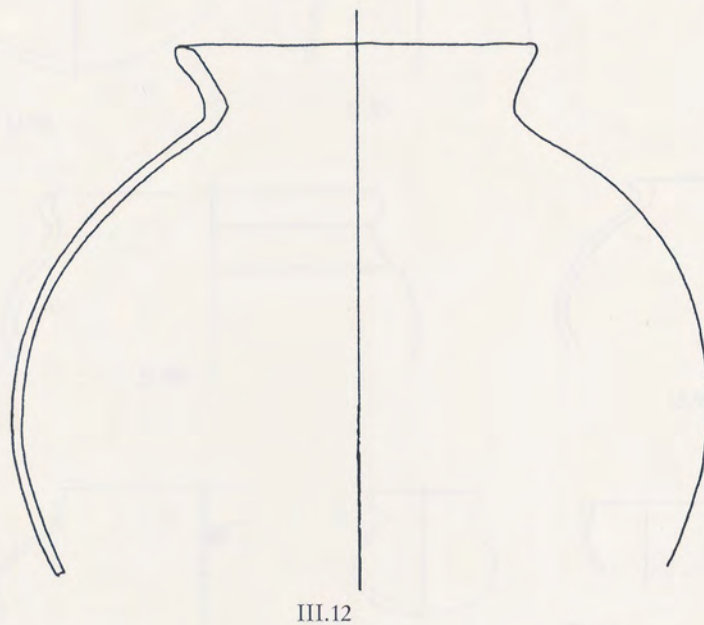
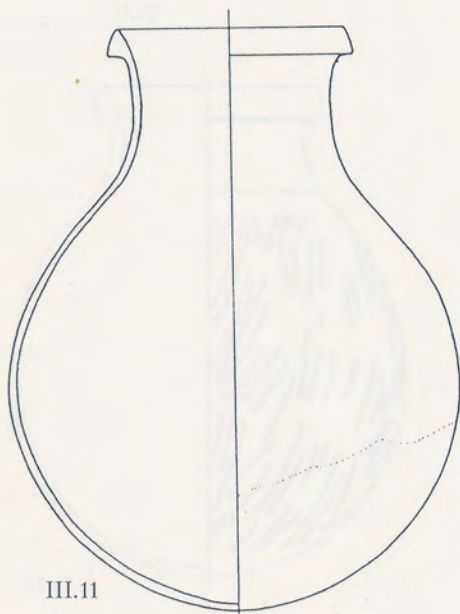
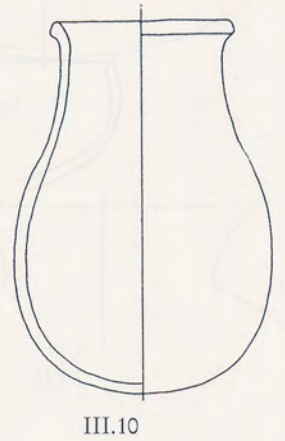
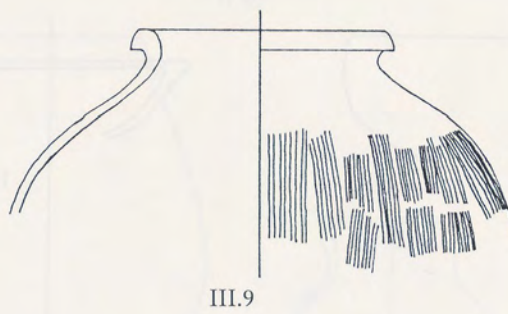
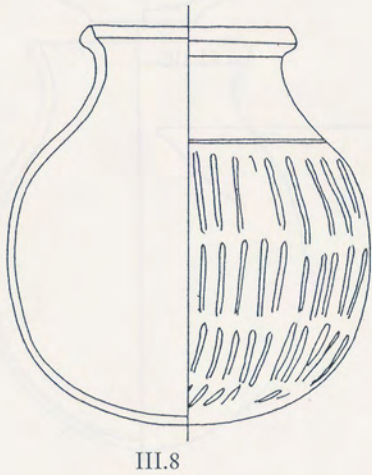
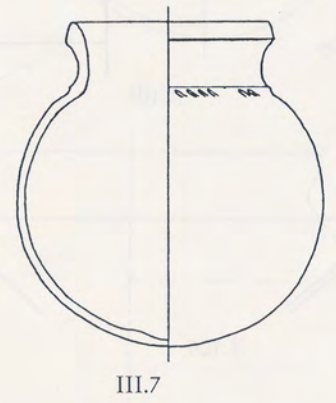
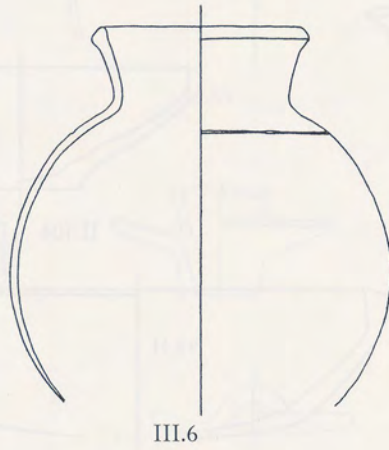
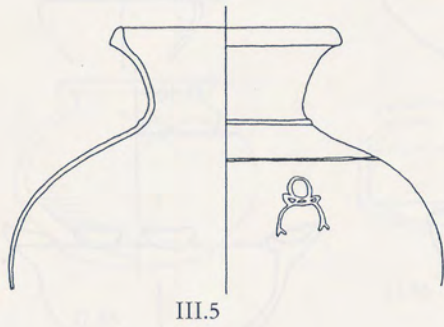
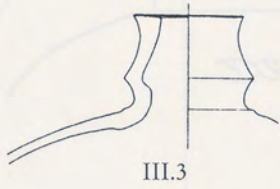
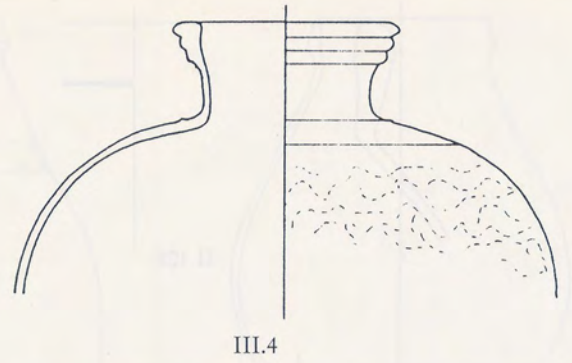
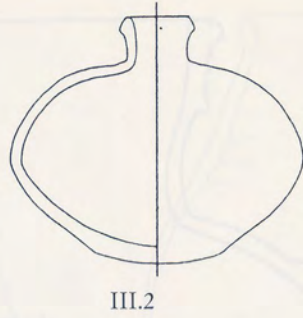
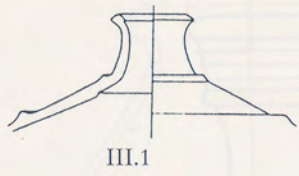

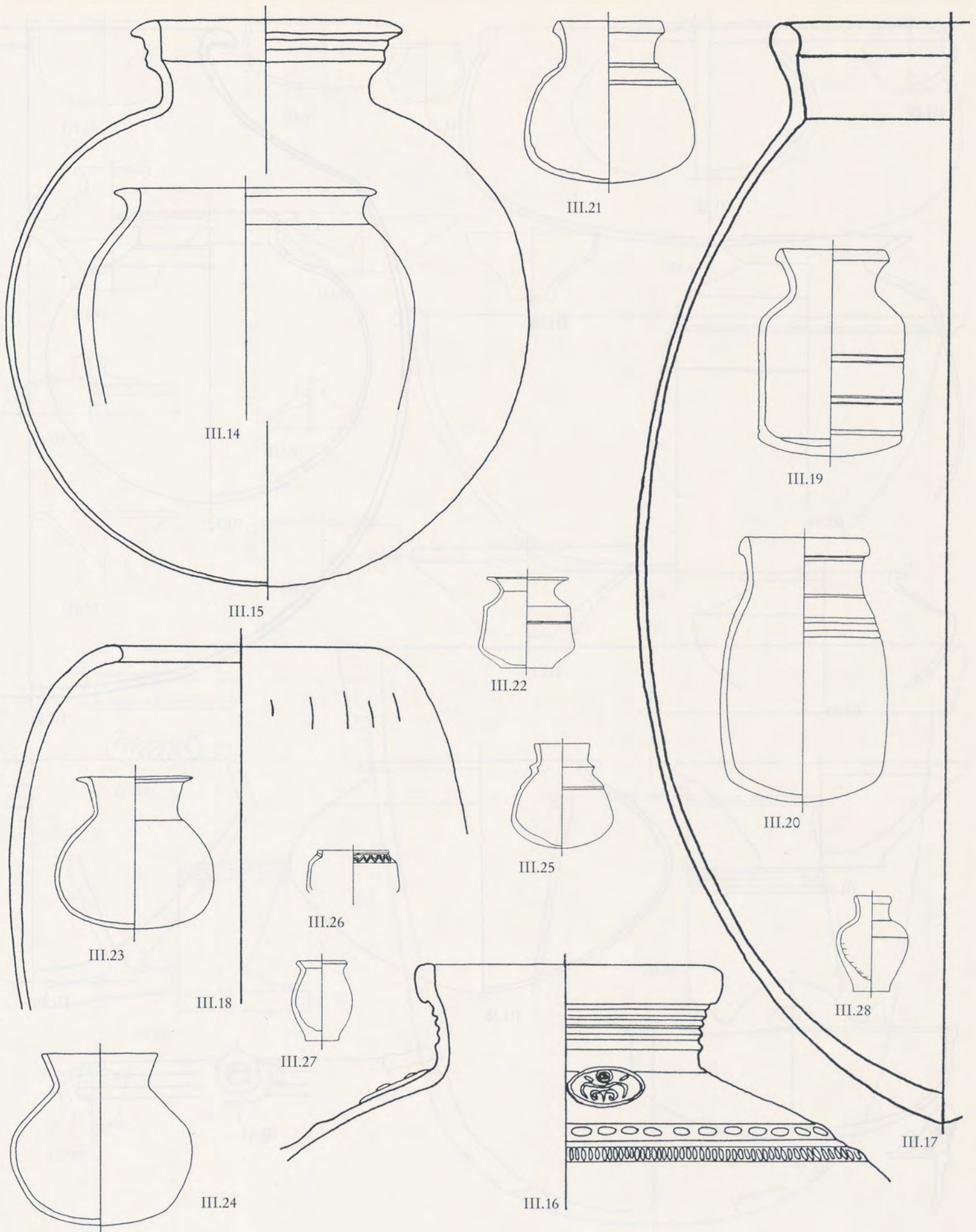

Pottery from Period III. 1/4

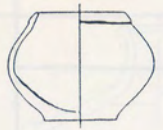

III.29

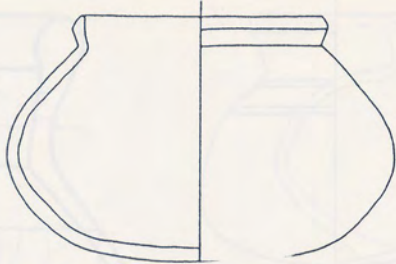

III.30

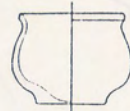

III.31

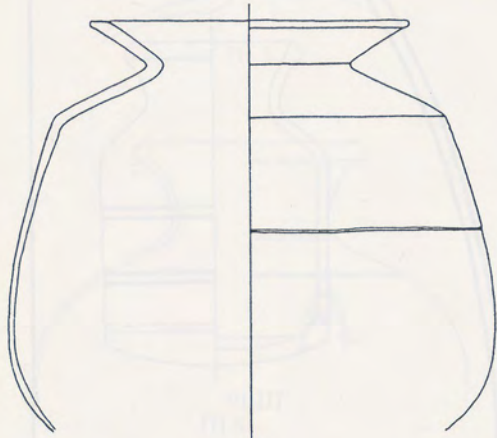

III.34

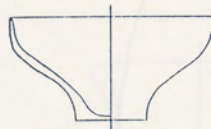

III.38

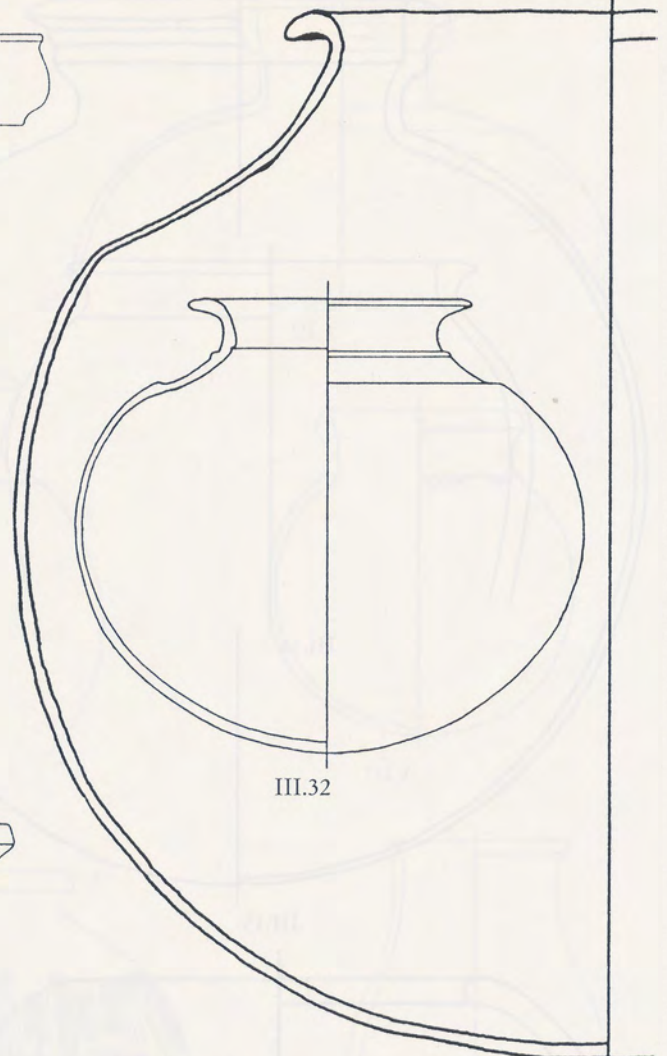

III.32

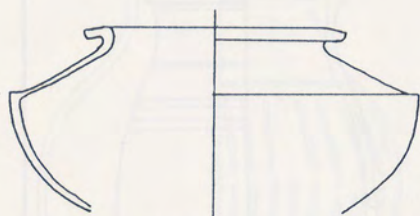

III.35

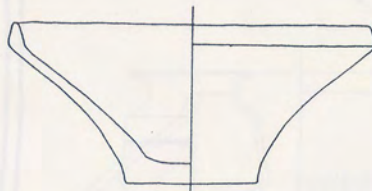

III.37

III.33

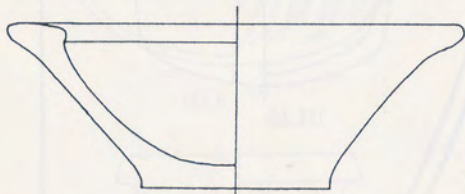

III.42

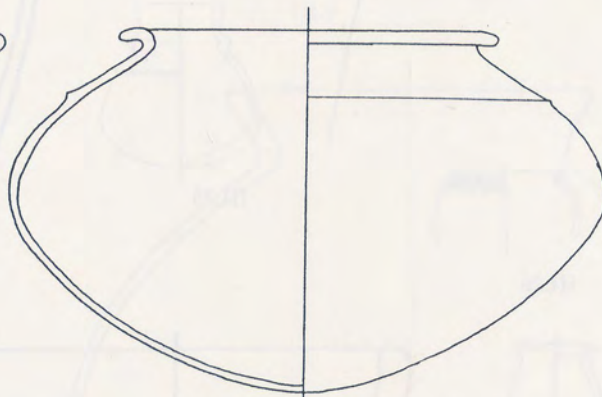

III.36

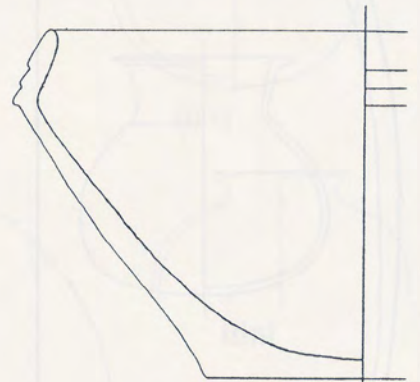

III.40

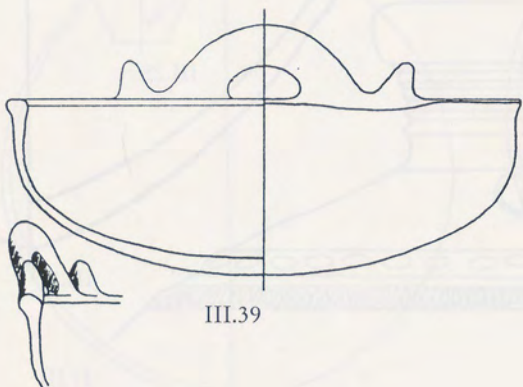

III.39

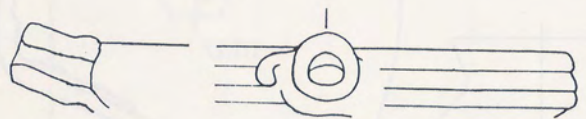

III.41



III.46

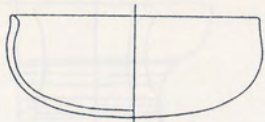

III.47

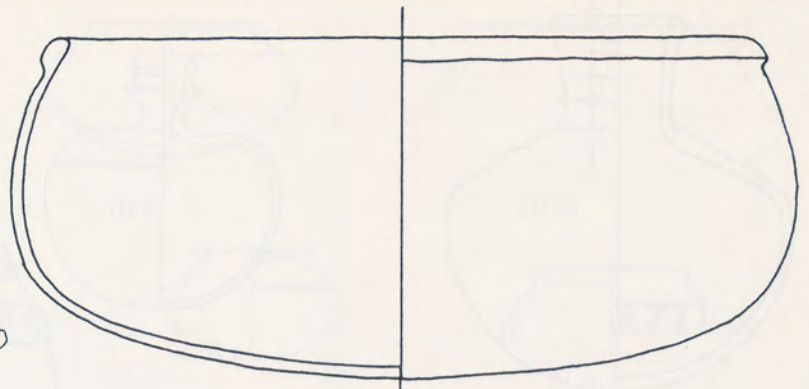

III.43

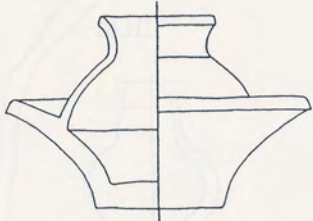

III.48

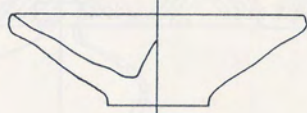

III.49

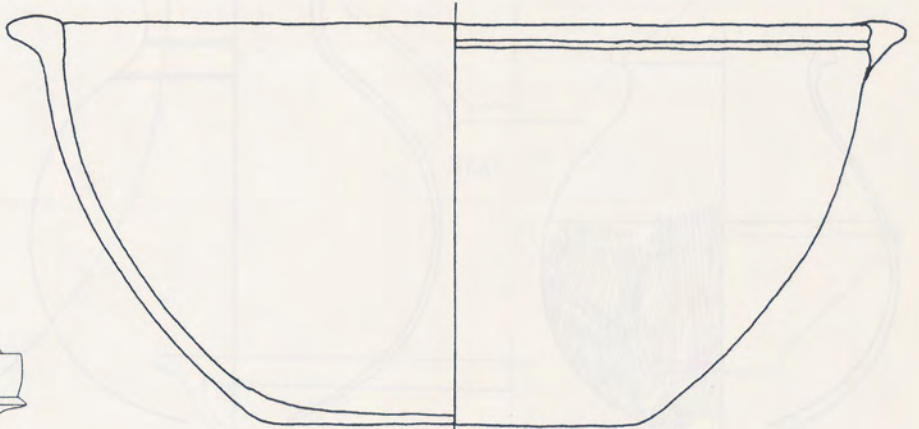

III.44

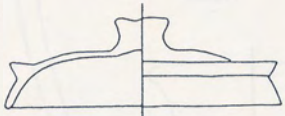

III.50

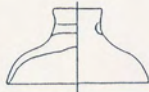

III.51



III.52



III.53



III.54

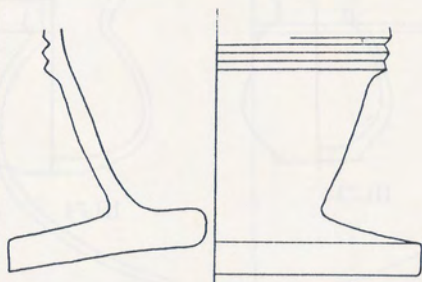
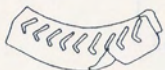

III.55

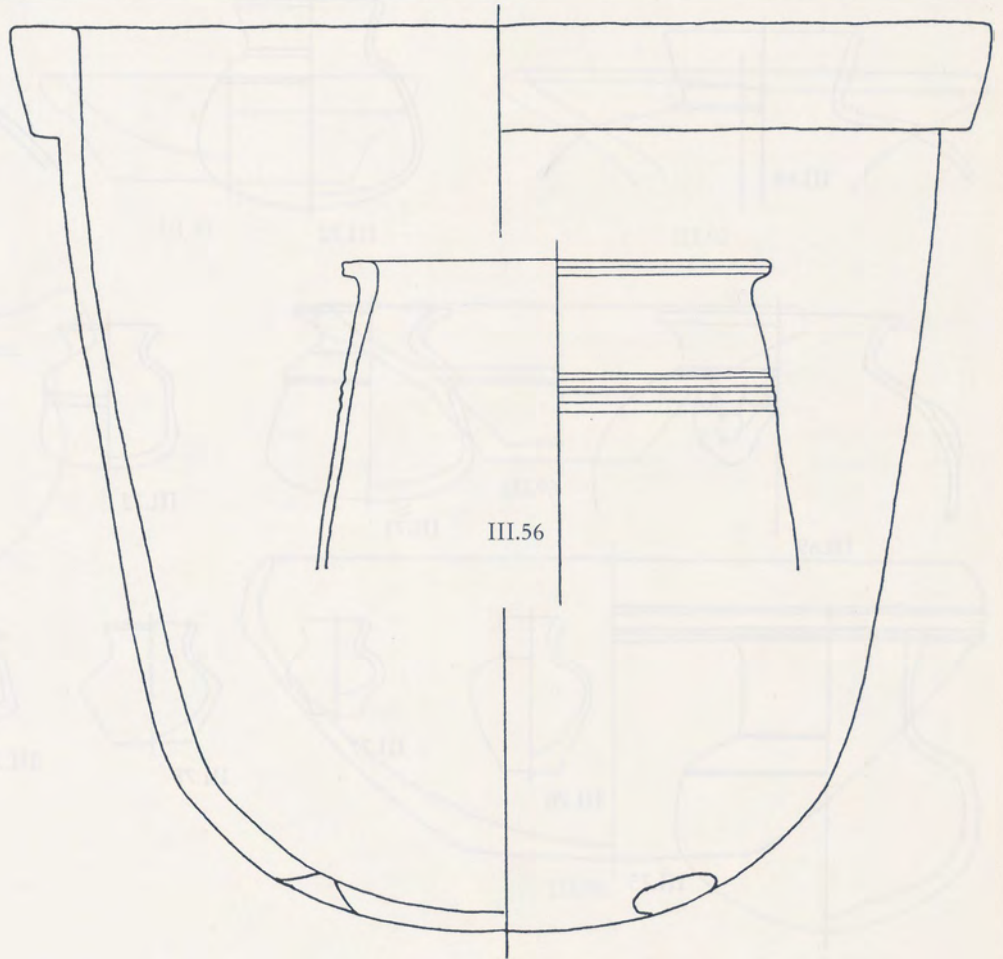

III.56

III.45

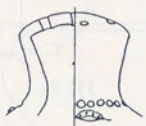

III.57

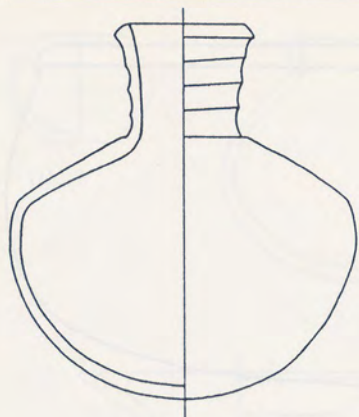

III.58

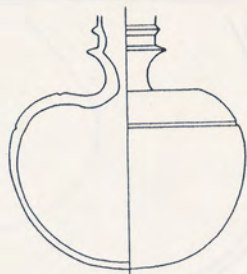

III.59

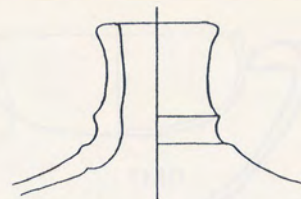

III.60

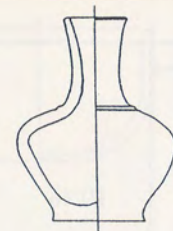

III.61

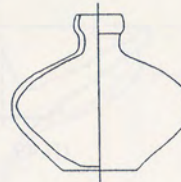

III.62

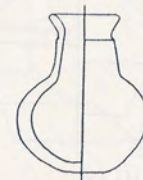

III.63

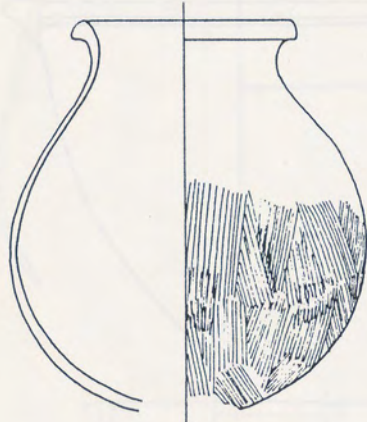

III.64

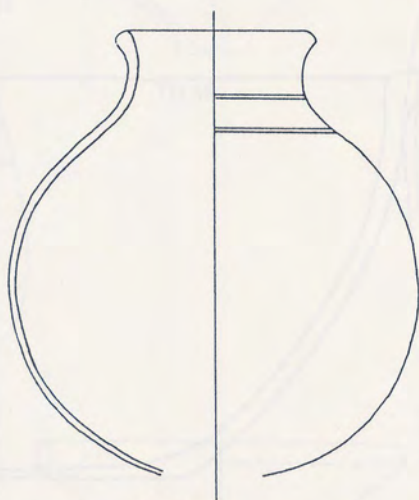

III.65

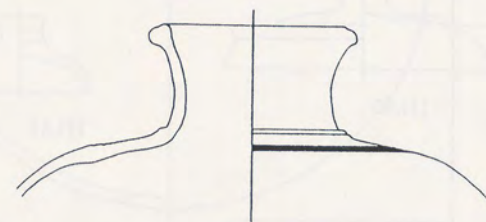

III.66

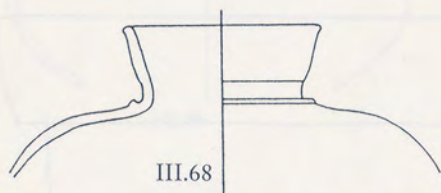

III.68



III.70

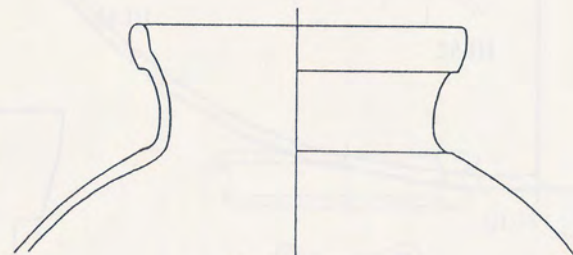

III.67

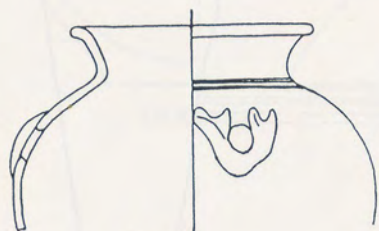

III.69



III.71



III.72

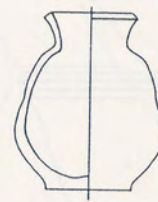

III.73

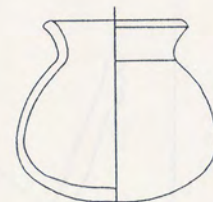

III.74

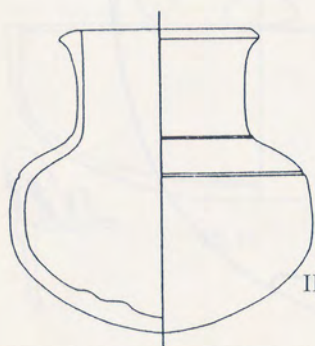

III.75

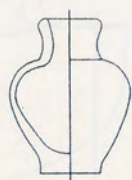

III.76



III.77



III.78



III.79



III.80



III.81

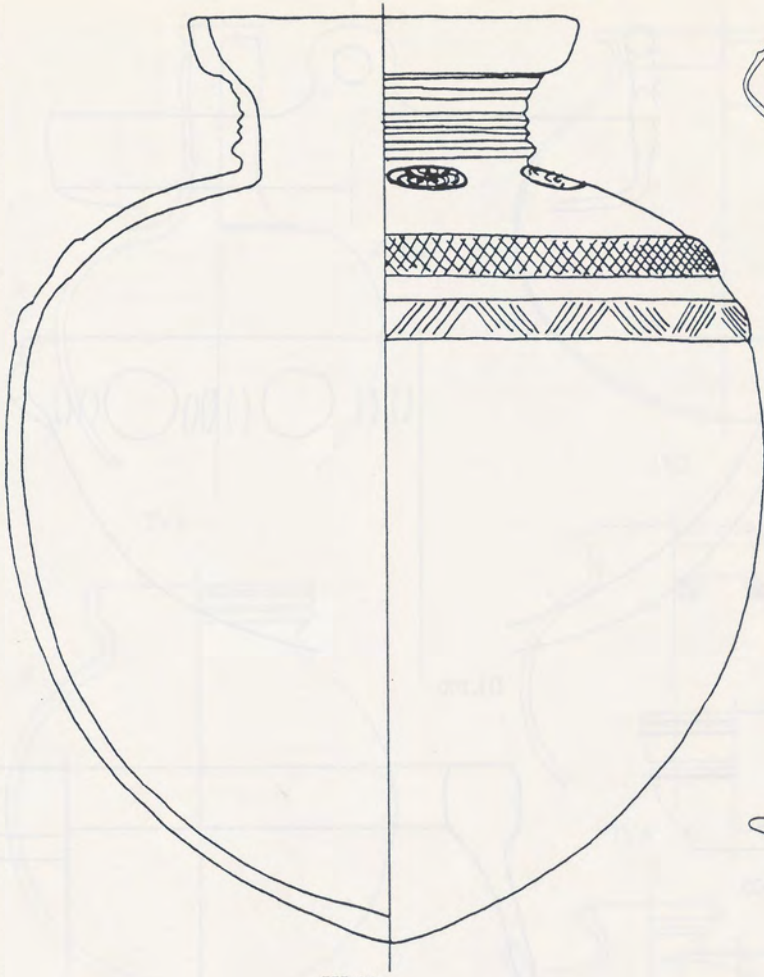

III.82

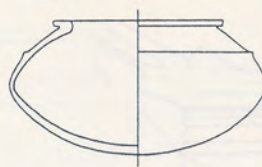

III.83

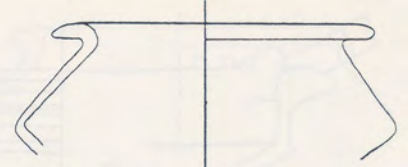

III.84

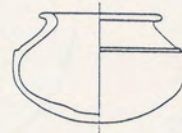

III.85

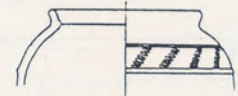

III.86

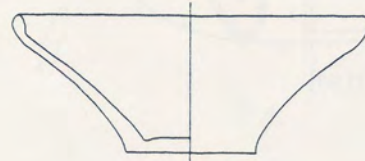

III.87

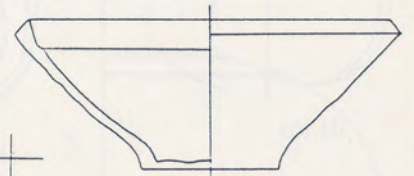

III.88

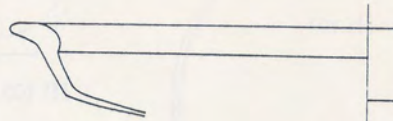

III.89

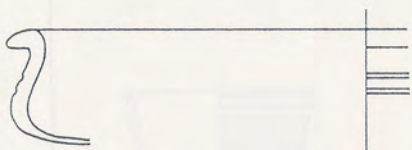

III.90

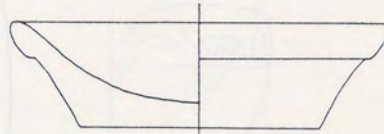

III.91



III.92

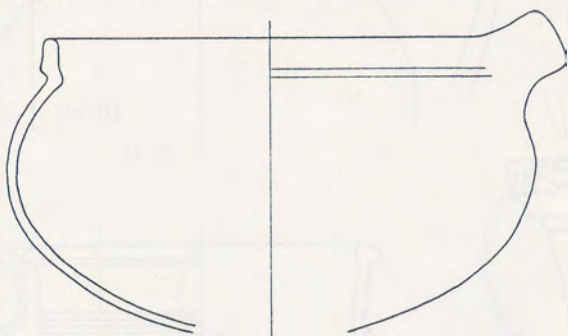

III.94

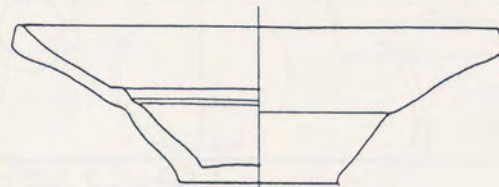

III.93

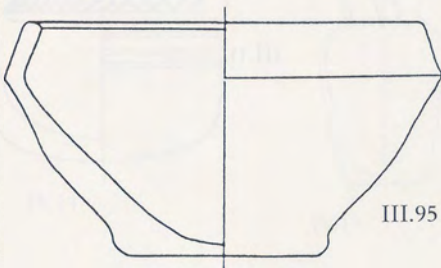

III.95

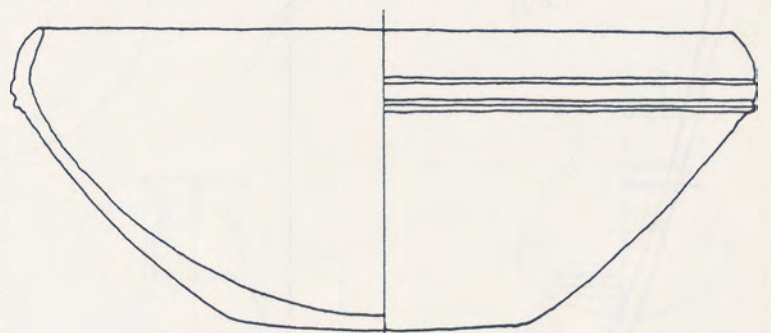

III.96

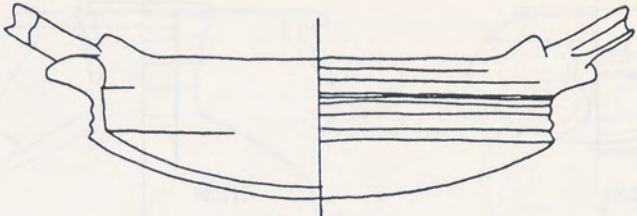

III.97

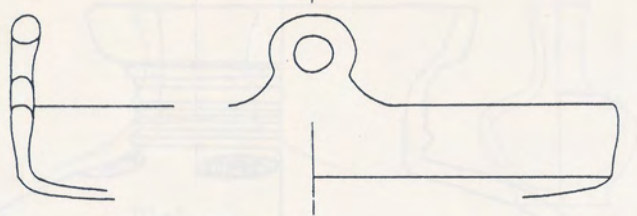

III.98

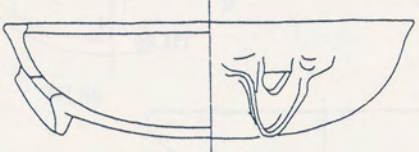

III.99

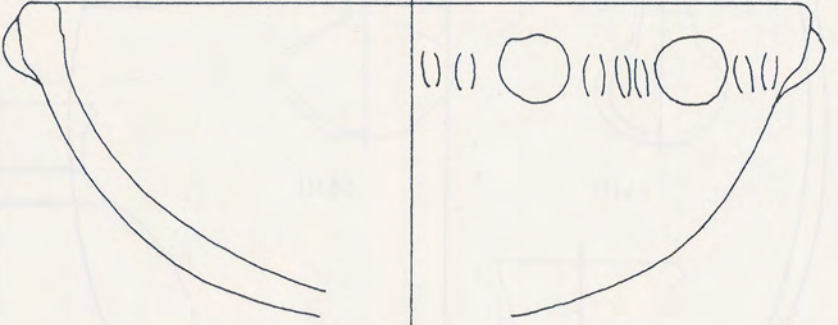

III.100

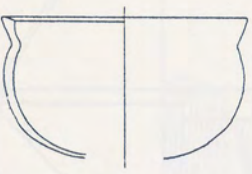

III.103

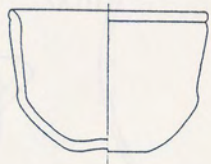

III.104

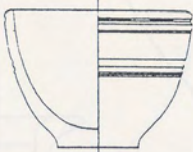

III.105



III.108



III.106

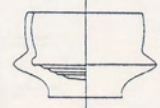

III.107

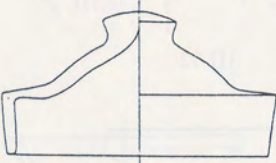

III.109

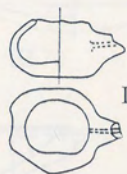

III.110

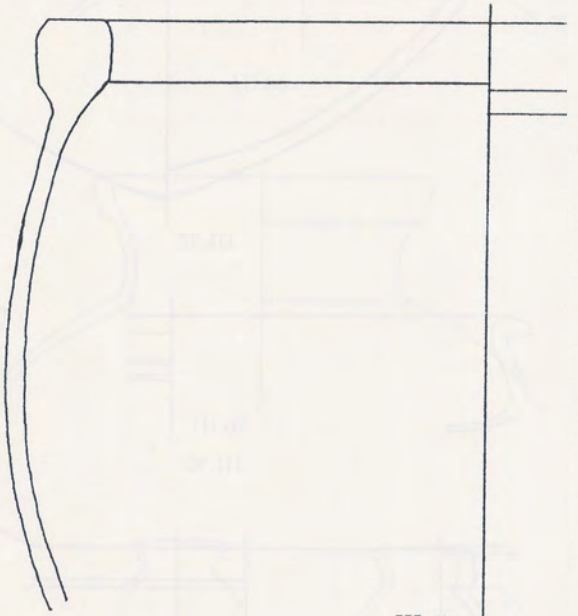

III.101

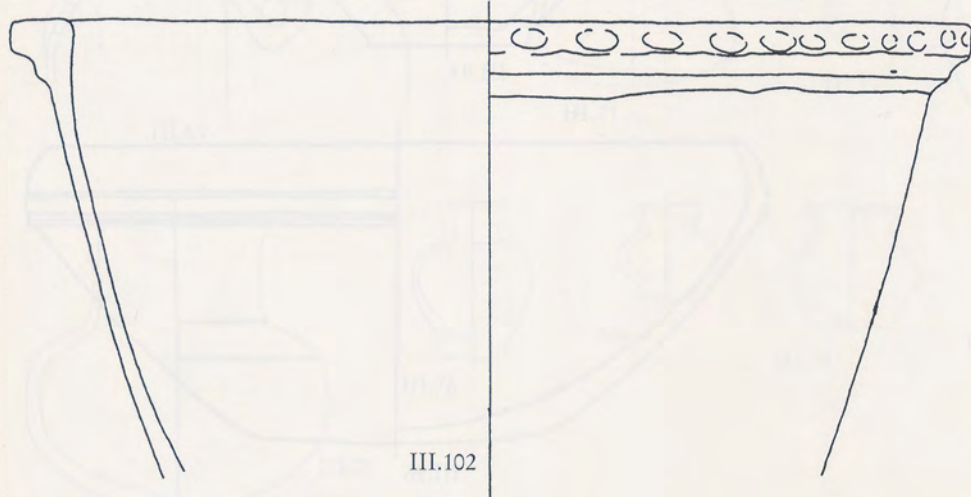

III.102

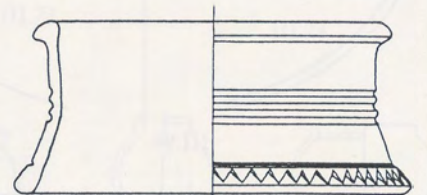

III.111

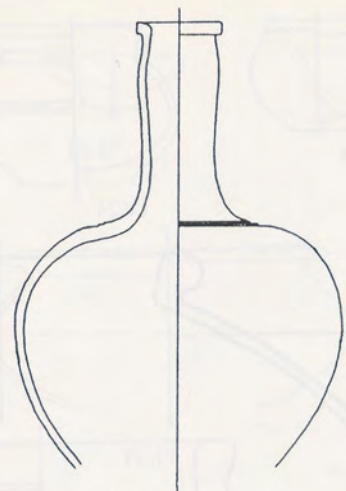

IV.1

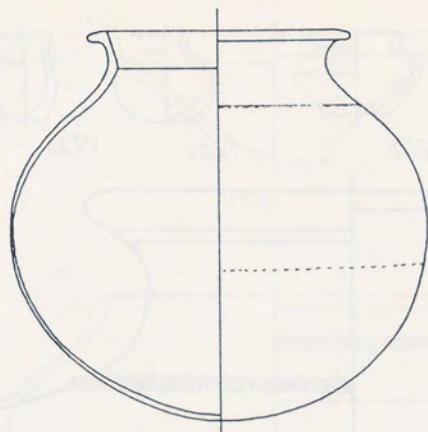

IV.2

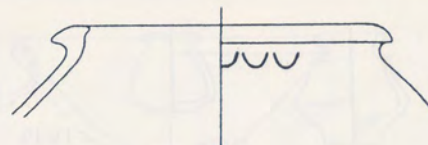

IV.3

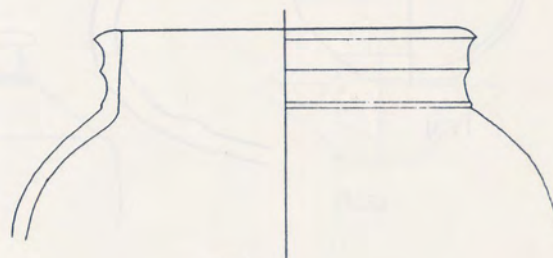

IV.4

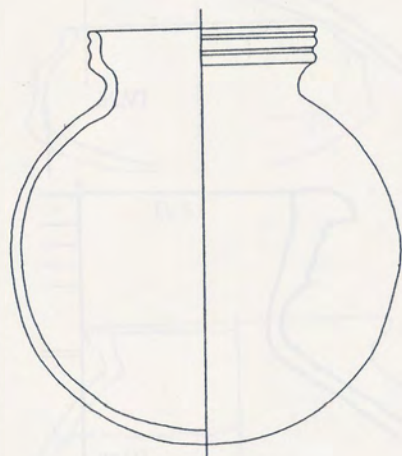

IV.5

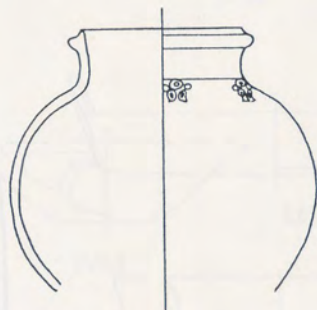

IV.6

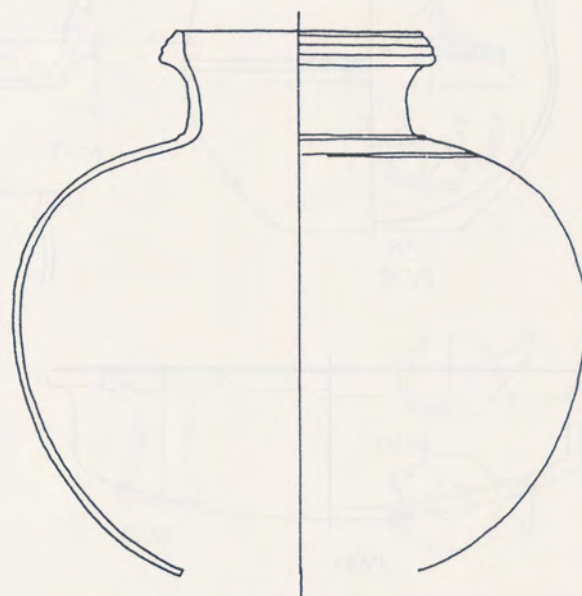

IV.7



IV.8

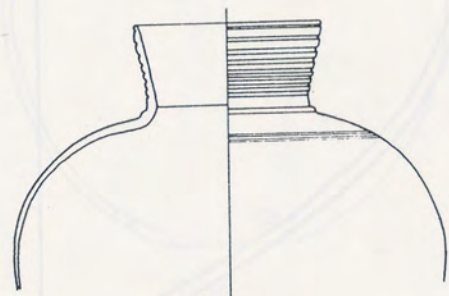

IV.10

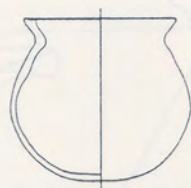

IV.12

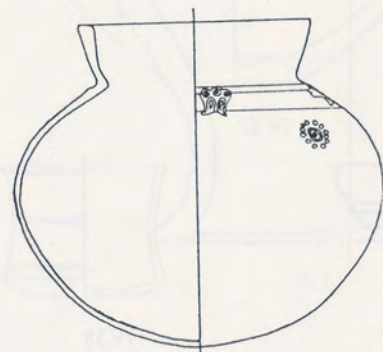

IV.11

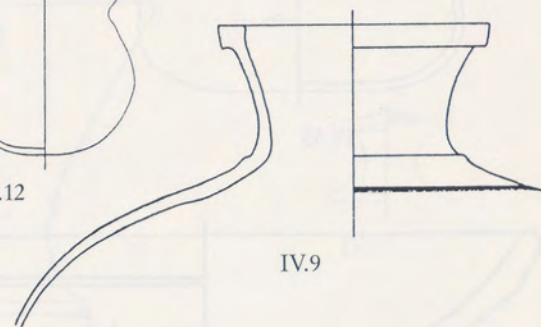

IV.9

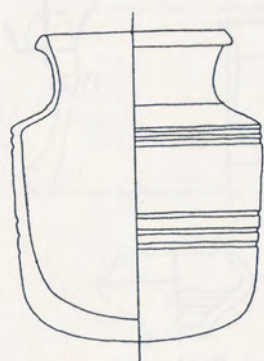

IV.14



IV.15

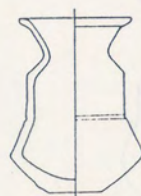

IV.16



IV.13

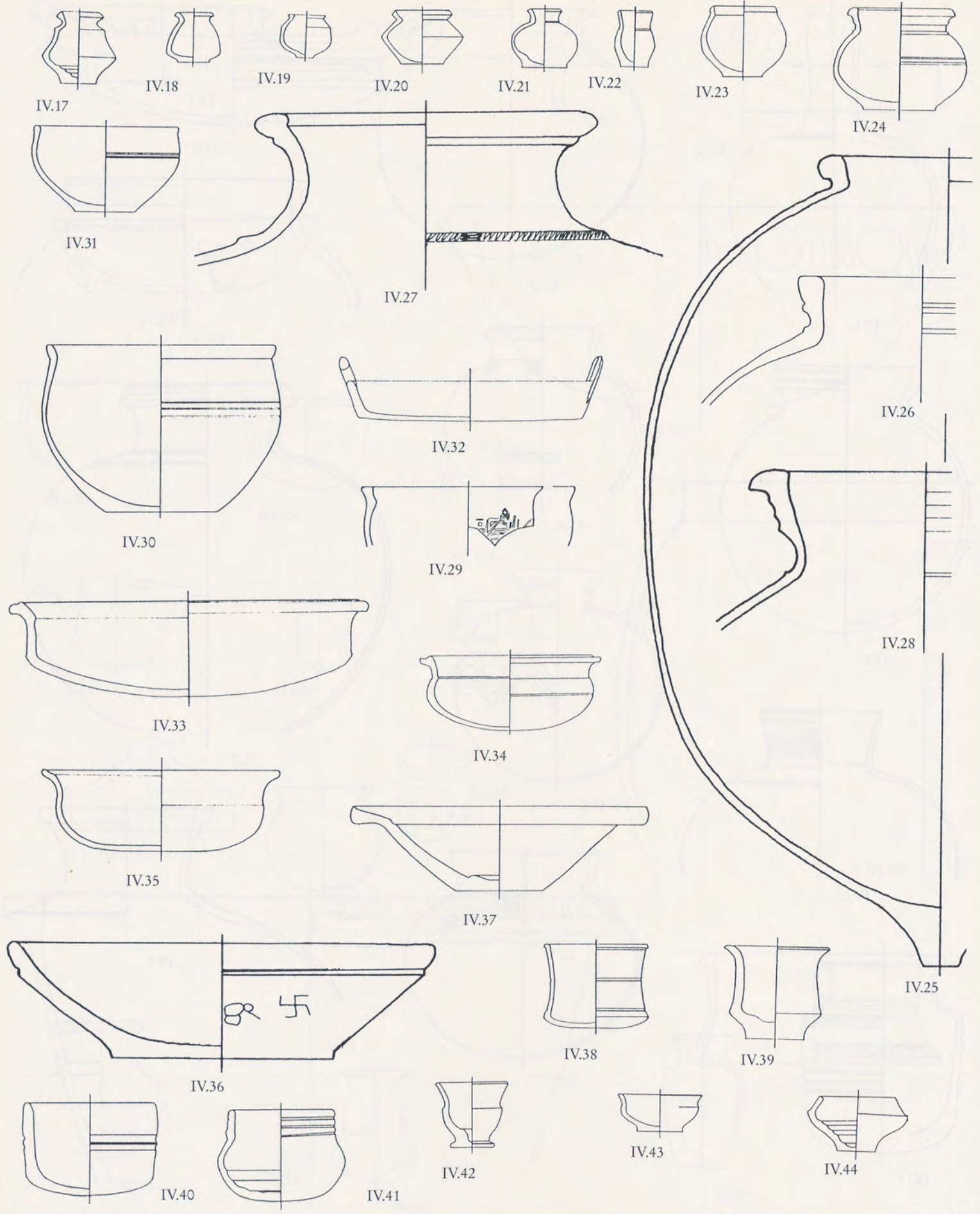

Pottery from Period IV. 1/4

Pottery from Period IV. 1/4



IV.47

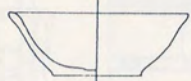

IV.48

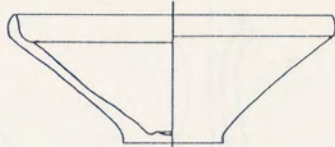

IV.45

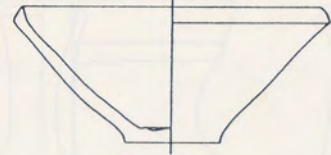

IV.46

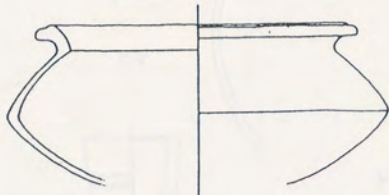

IV.49

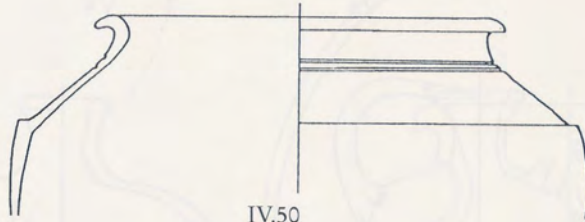

IV.50



IV.52

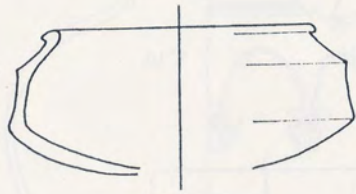

IV.51

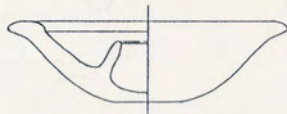

IV.53

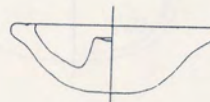

IV.54

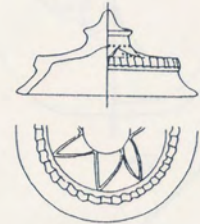

IV.55

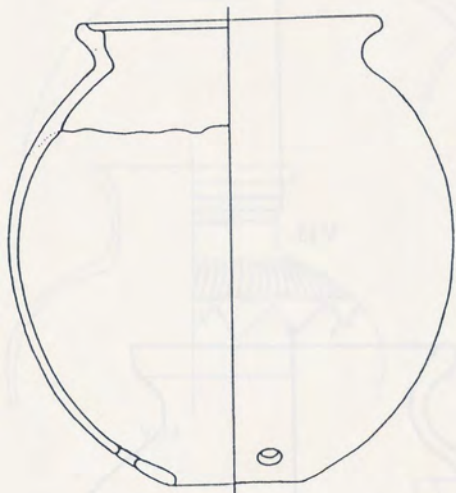

IV.56

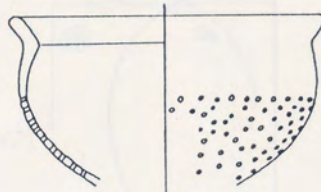

IV.57



IV.58



IV.59

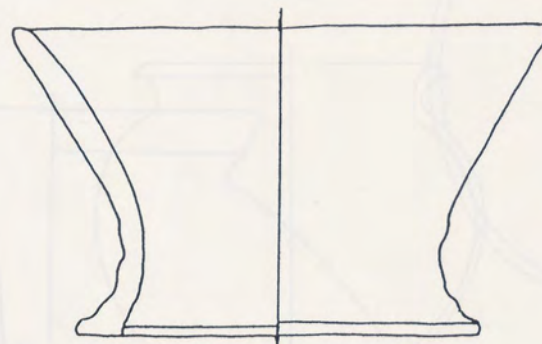
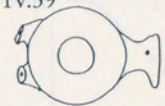

IV.61

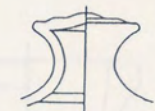

IV.62

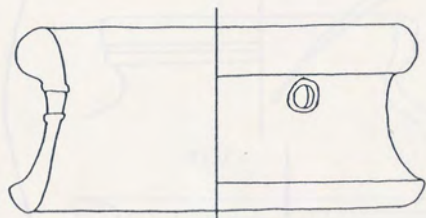

IV.60

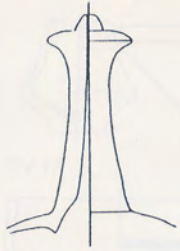

V.1

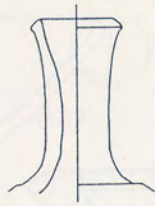

V.2

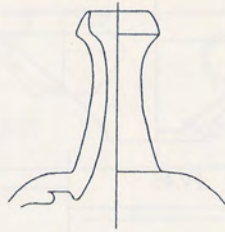

V.3

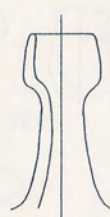

V.4



V.8

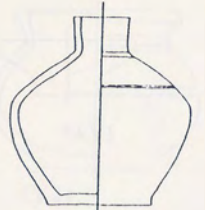

V.9

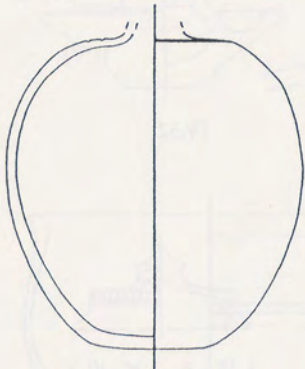

V.5

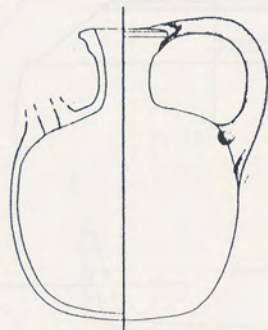

V.6

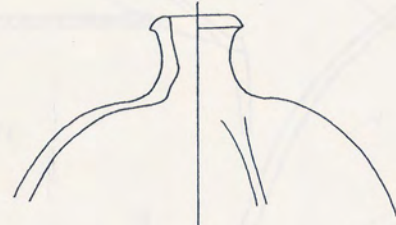

V.7

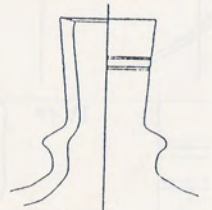

V.10

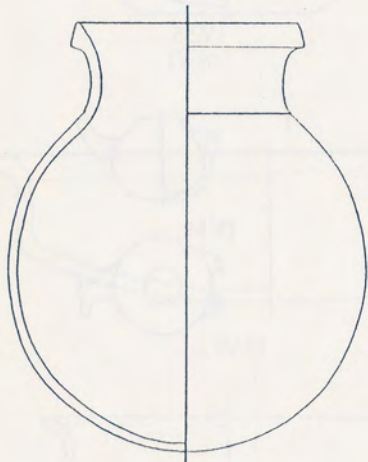

V.11

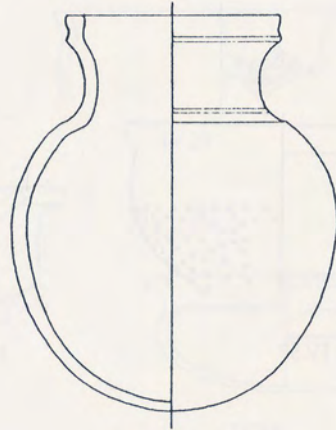

V.12

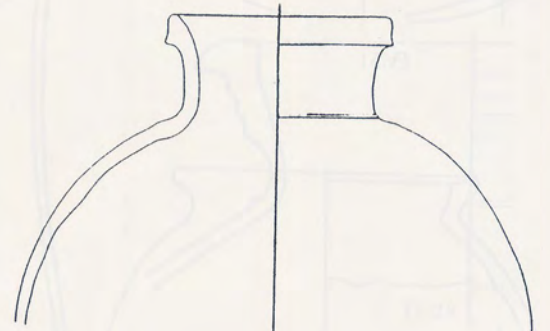

V.13

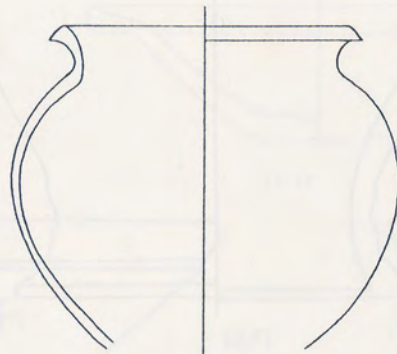

V.15

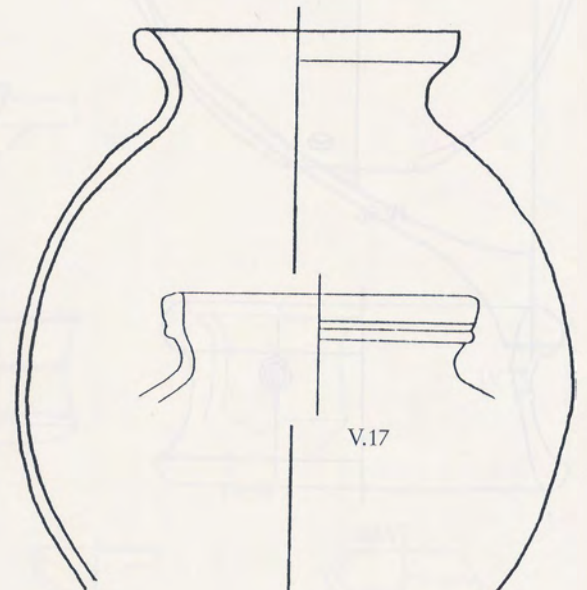

V.17



V.14

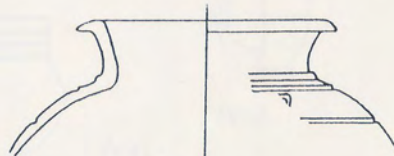

V.18

V.16

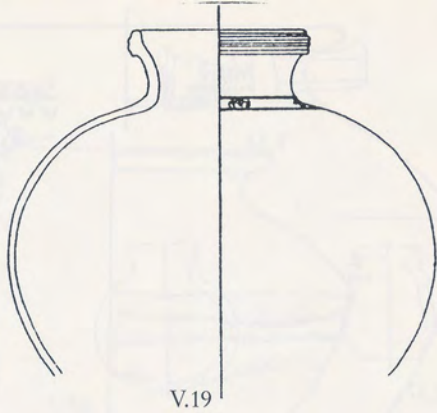

V.19

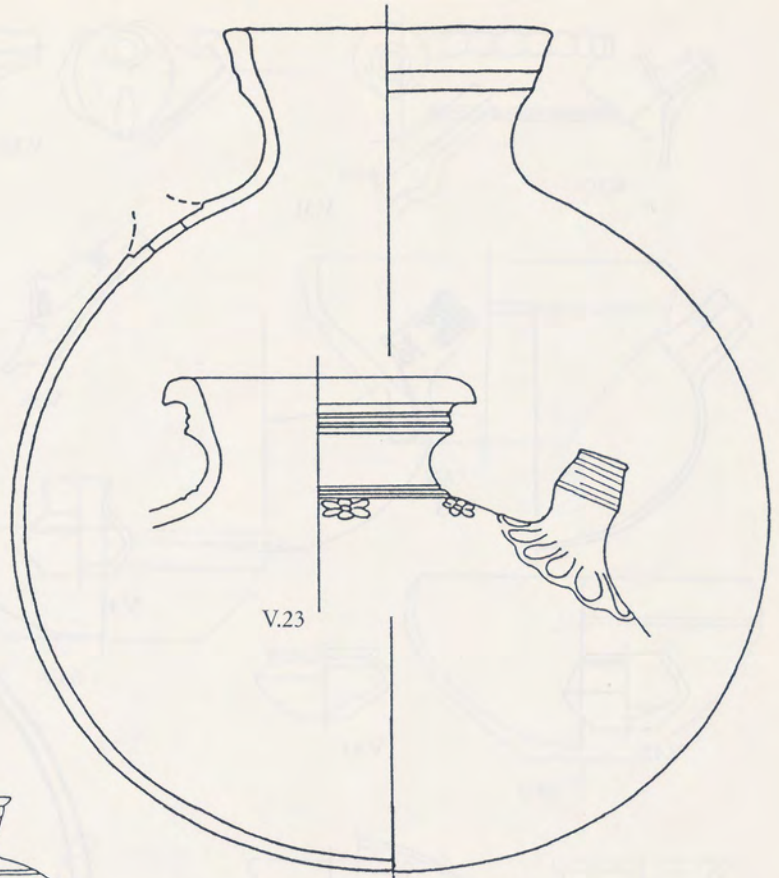

V.23

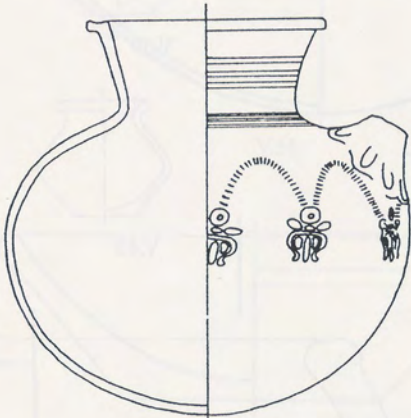

V.20

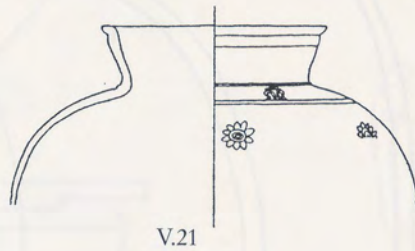

V.21



V.27

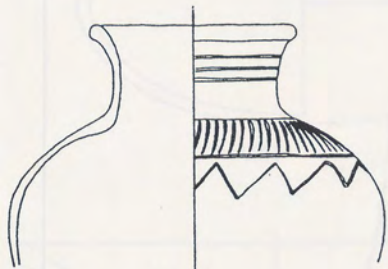

V.24

V.22

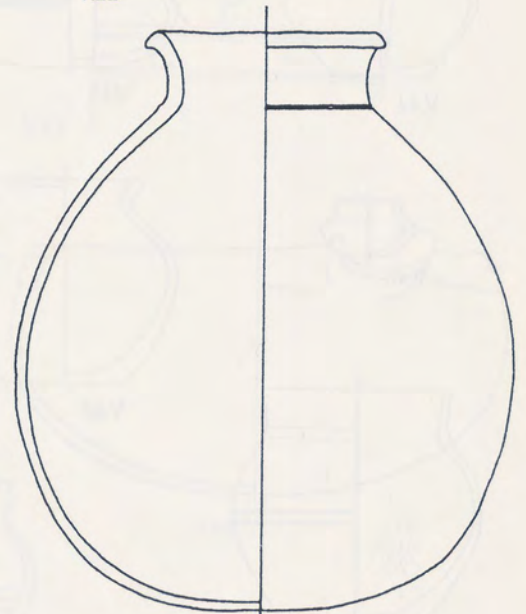

V.25

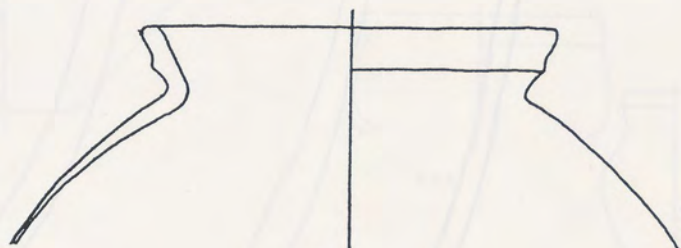

V.26

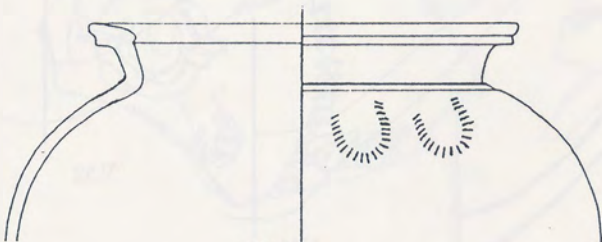

V.28

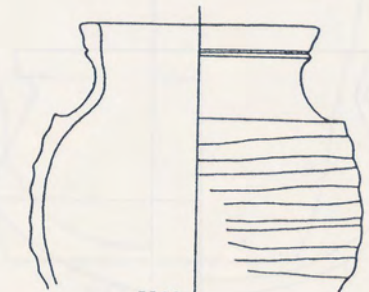

V.29

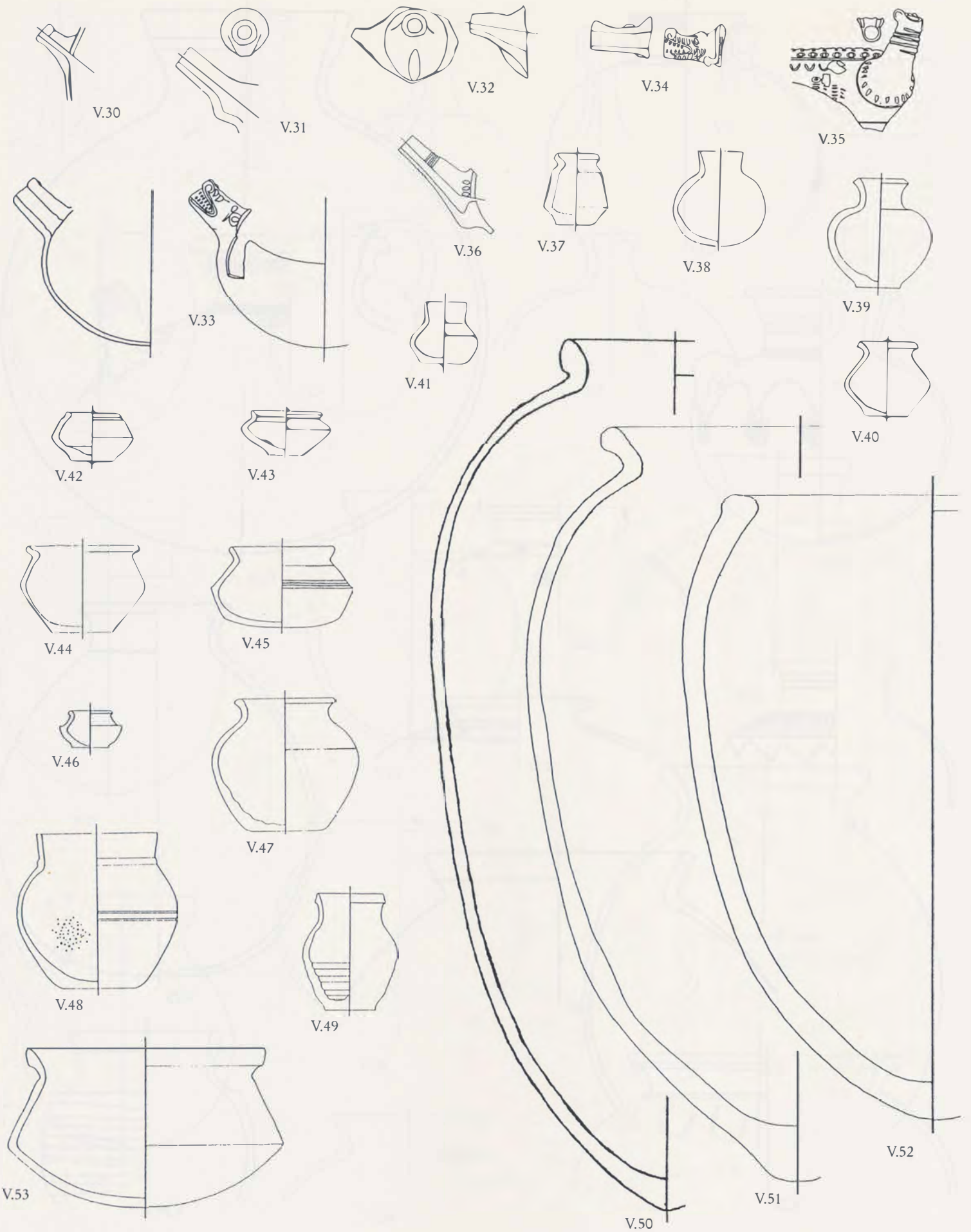

Pottery from Period V. 1/4

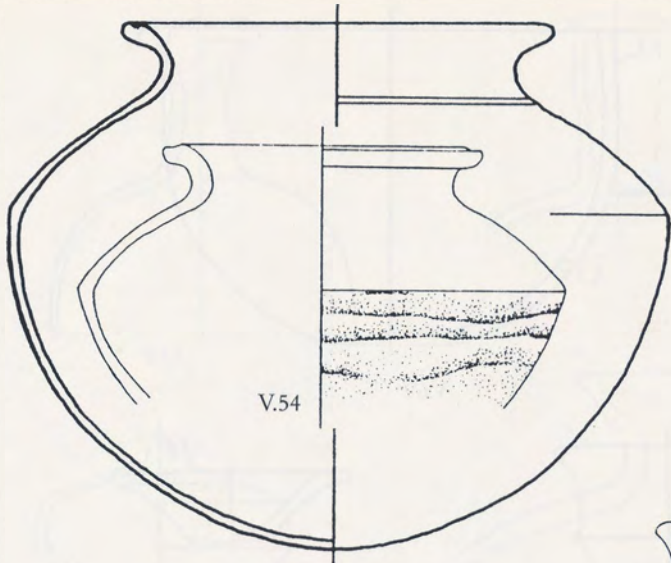

V.54

V.55

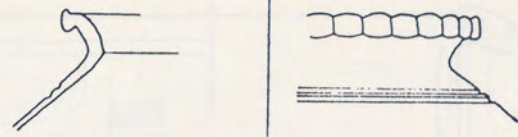

V.56

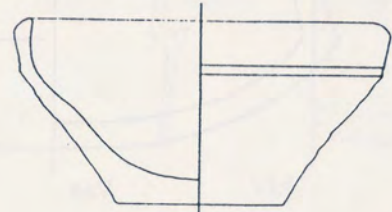

V.57

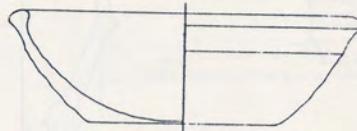

V.60

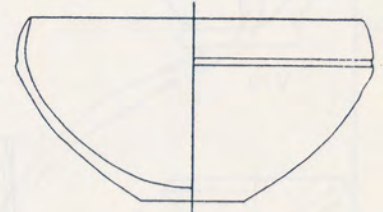

V.59

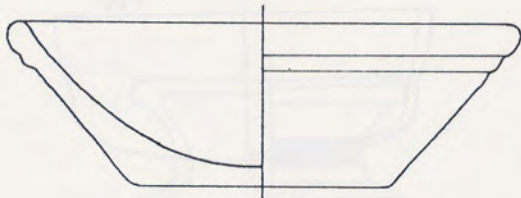

V.58

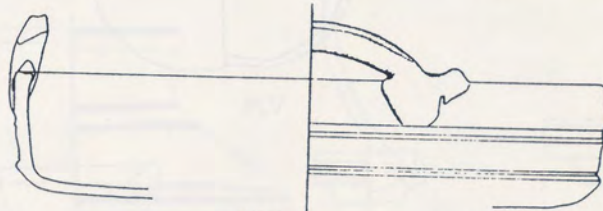

V.63

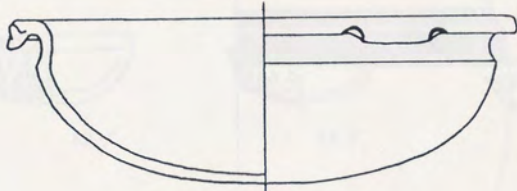

V.61

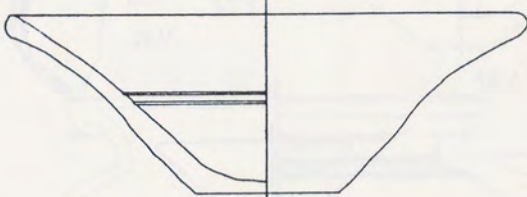

V.62

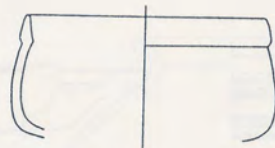

V.65

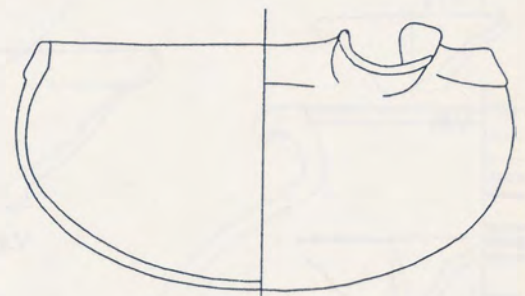

V.64



V.66

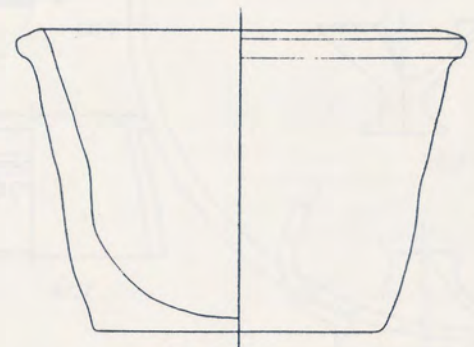

V.67

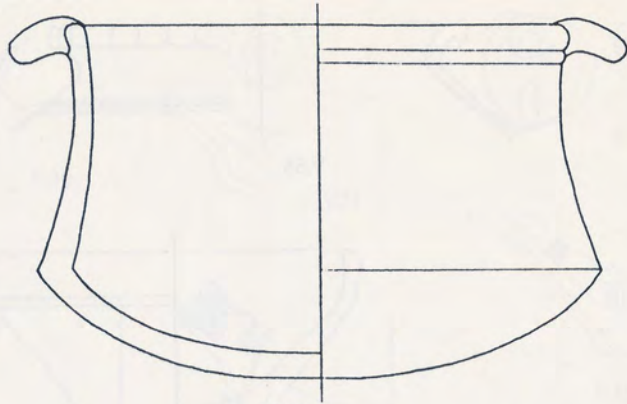

V.68

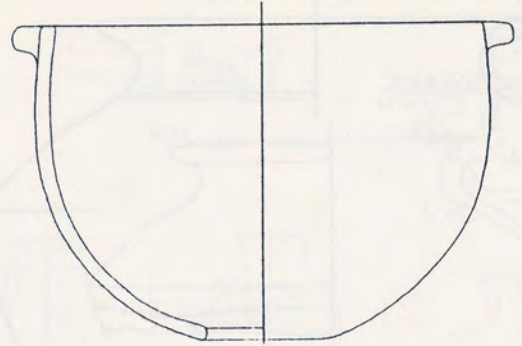

V.69

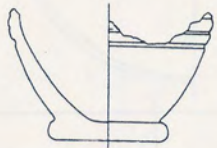

V.70



V.72

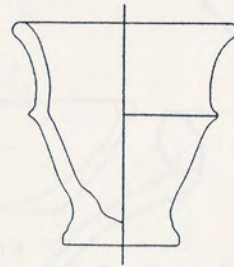

V.71

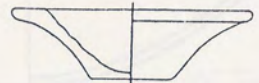

V.73

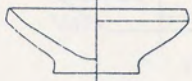

V.77

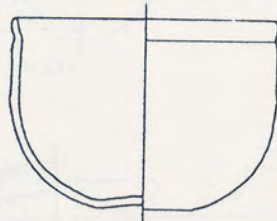

V.75

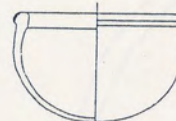

V.76

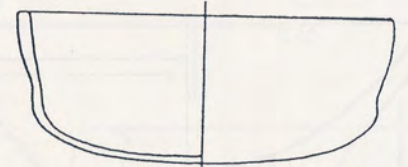

V.74



V.78



V.79

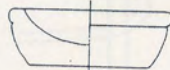

V.80



V.82



V.83



V.84



V.85

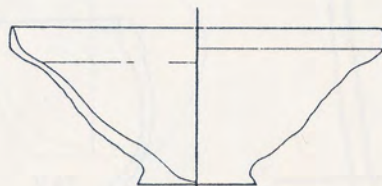

V.86

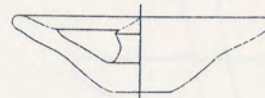

V.87

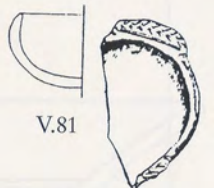

V.81

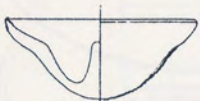

V.89

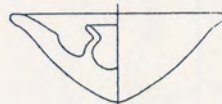

V.90

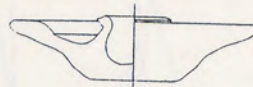

V.91

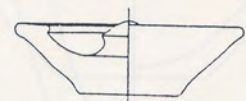

V.88



V.93



V.92



V.95

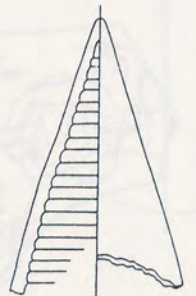

V.99

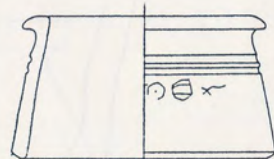

V.96



V.97

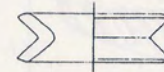

V.98

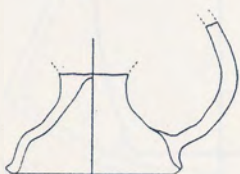

V.94

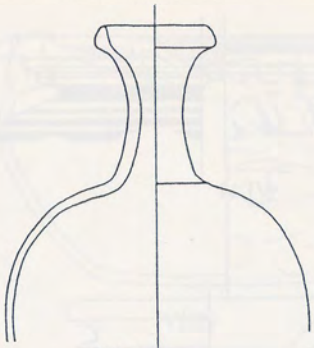

VI.1

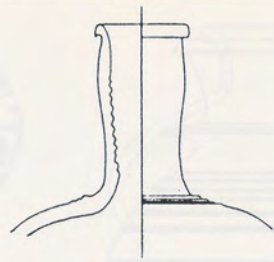

VI.2



VI.3

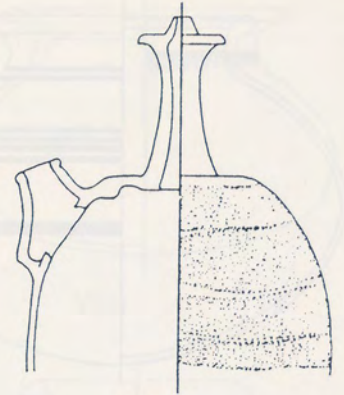

VI.4

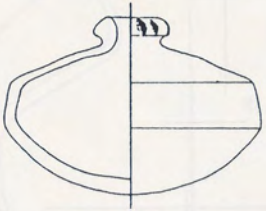

VI.5

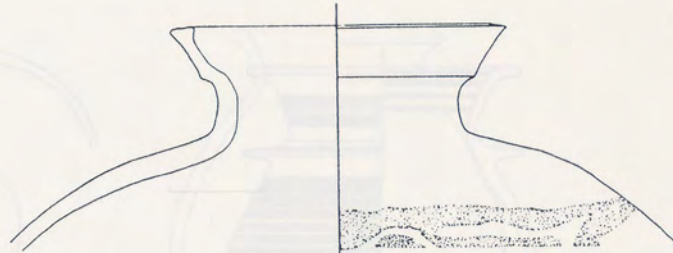

VI.6

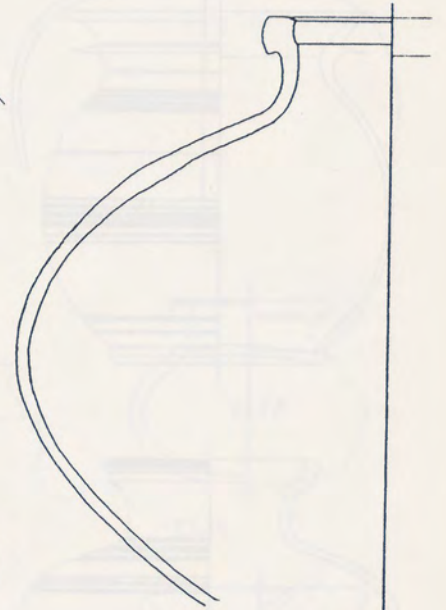

VI.7

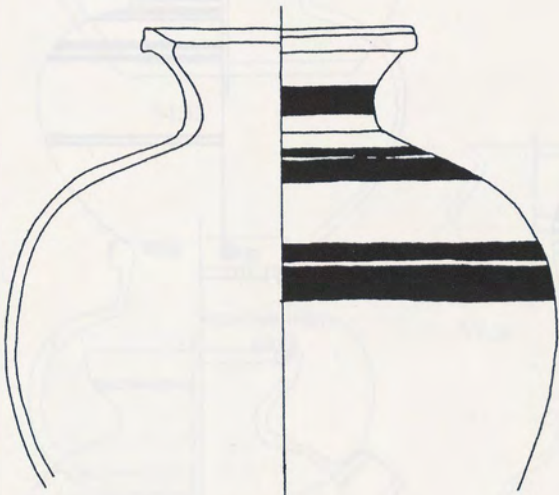

VI.8

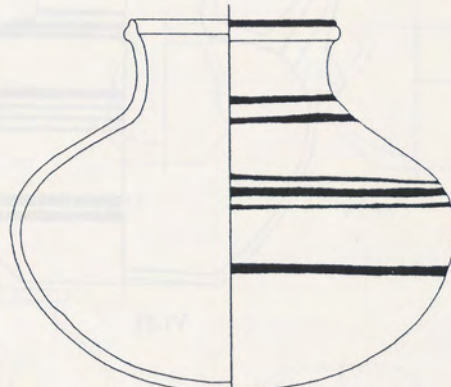

VI.12

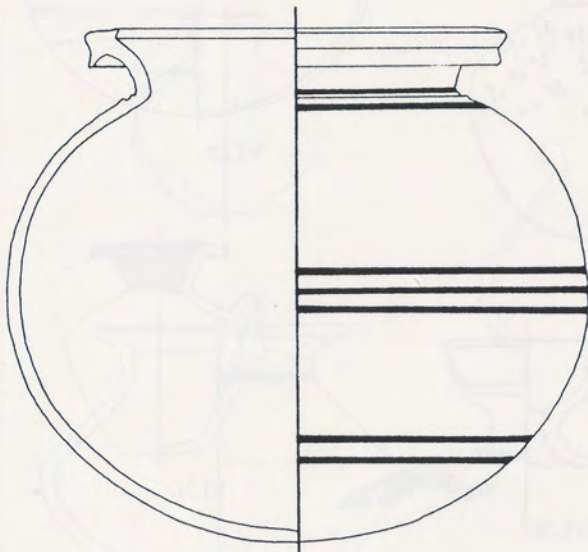

VI.10

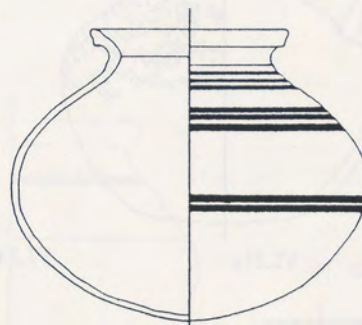

VI.11

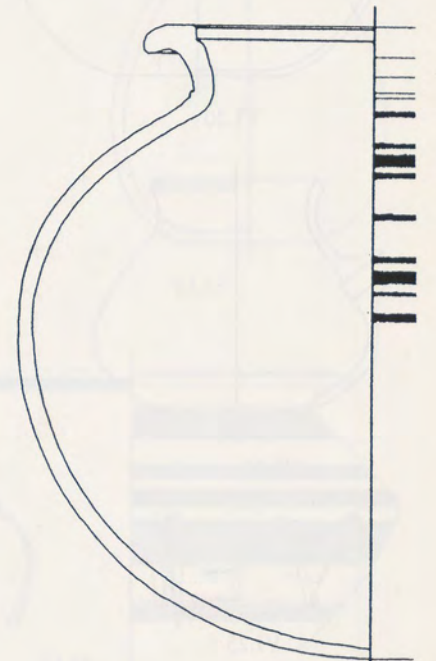

VI.9

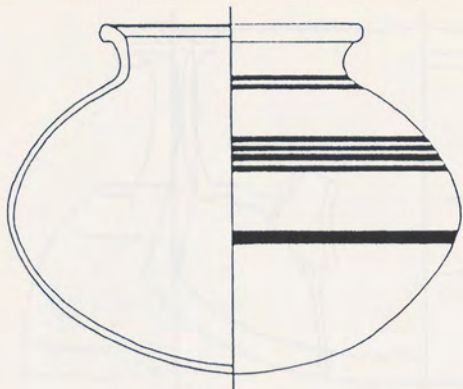

VI.13

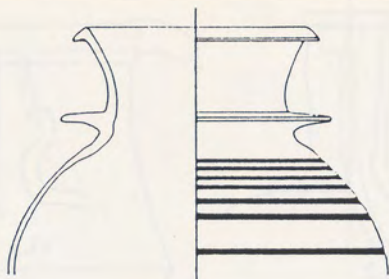

VI.15

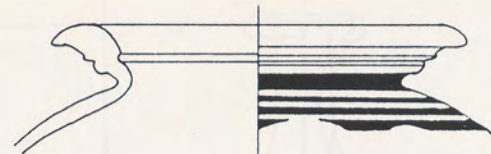

VI.14

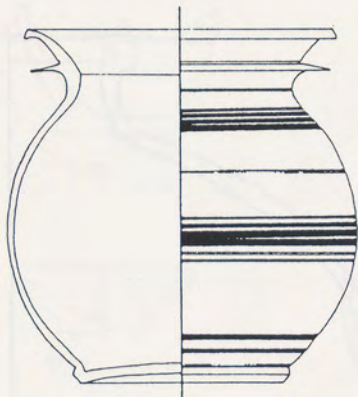

VI.16

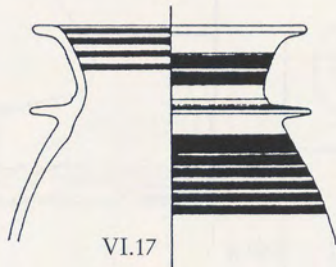

VI.17

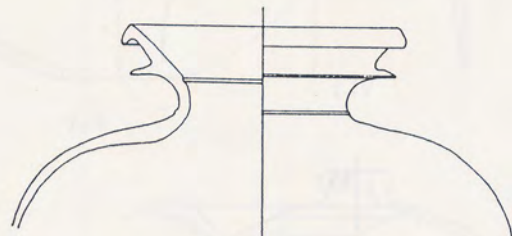

VI.18

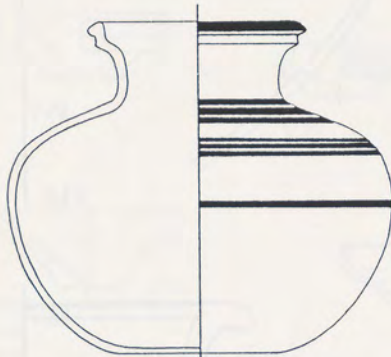

VI.20

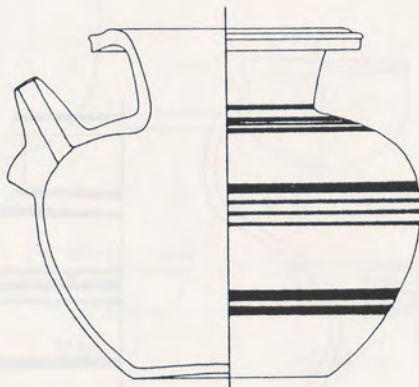

VI.21

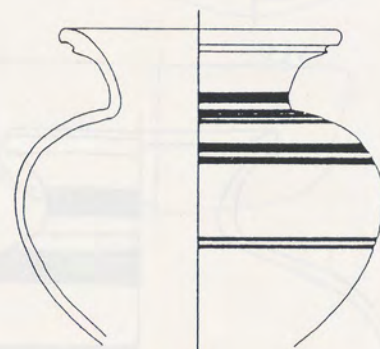

VI.19



VI.22

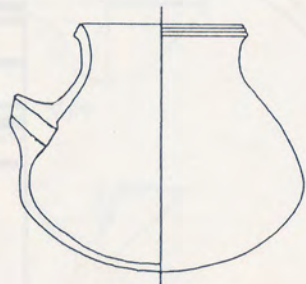

VI.24

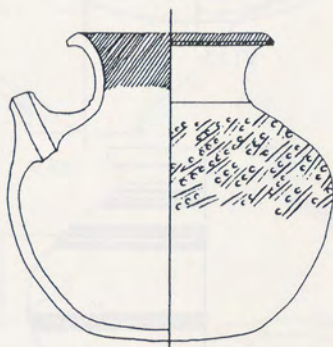

VI.23a



VI.23b

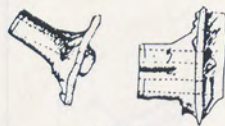

VI.25

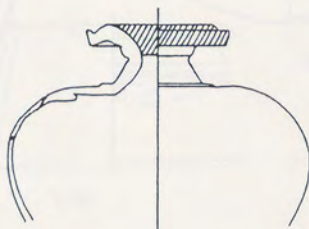

VI.27

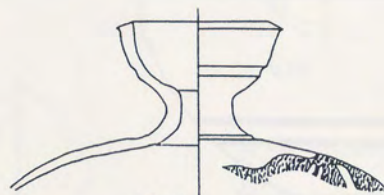

VI.28



VI.26

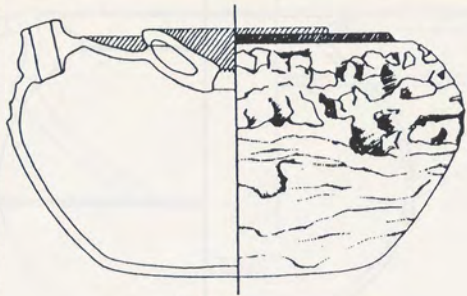

VI.29

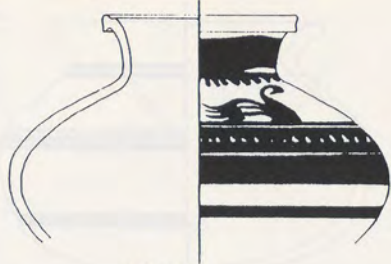

VI.30

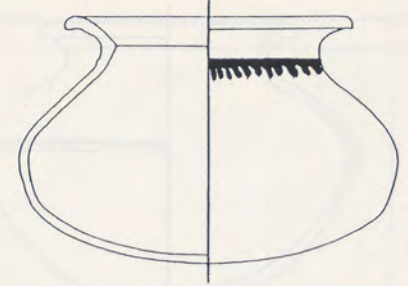

VI.31

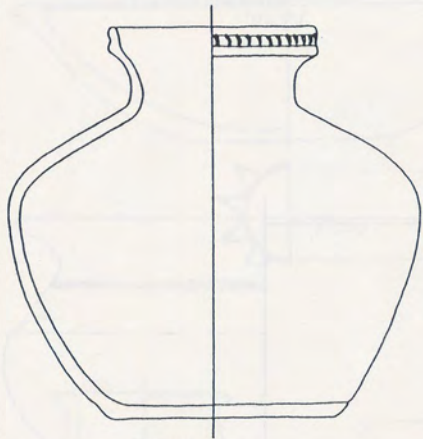

VI.32

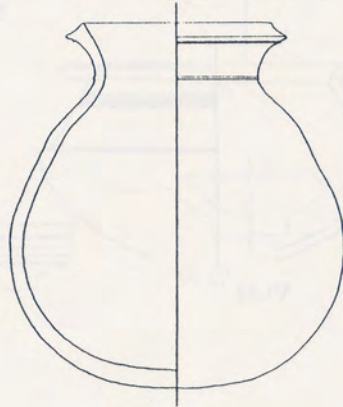

VI.33

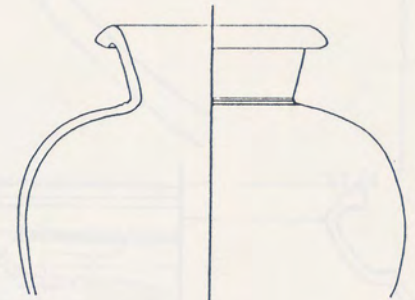

VI.34

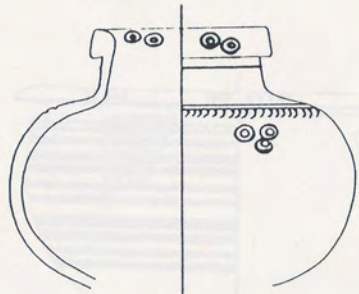

VI.35

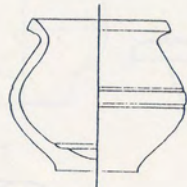

VI.36



VI.37

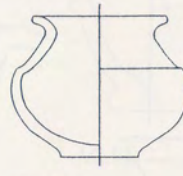

VI.38

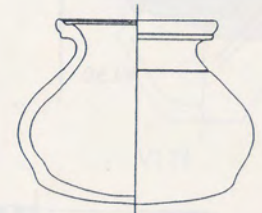

VI.39

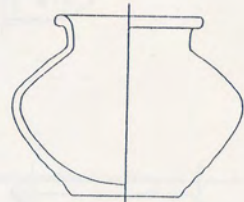

VI.41

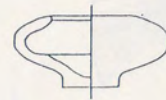

VI.42



VI.40

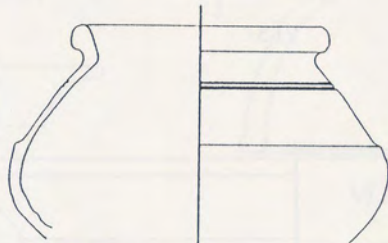

VI.45

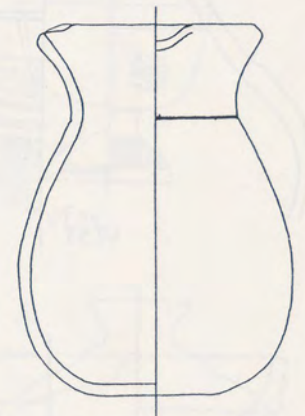

VI.43

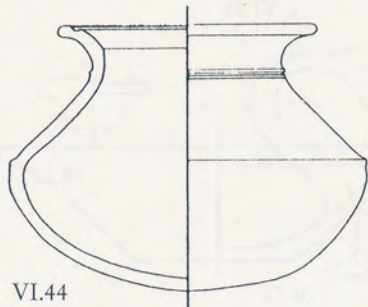

VI.44

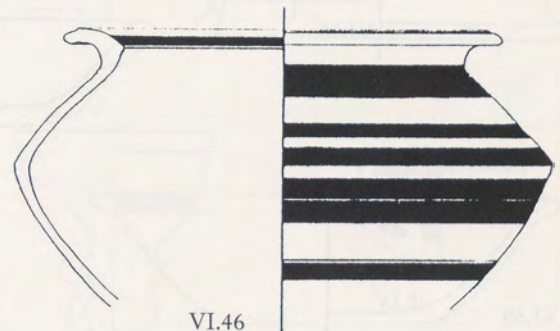

VI.46

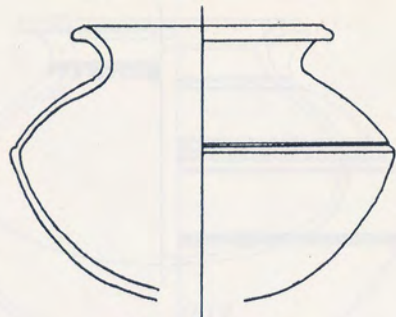

VI.47

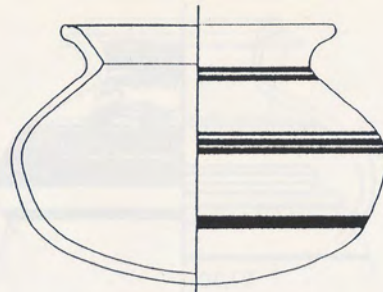

VI.48

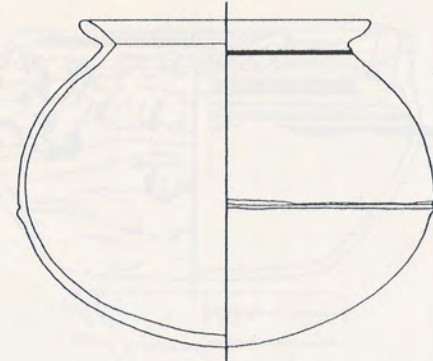

VI.49

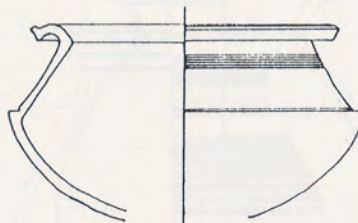

VI.52



VI.51

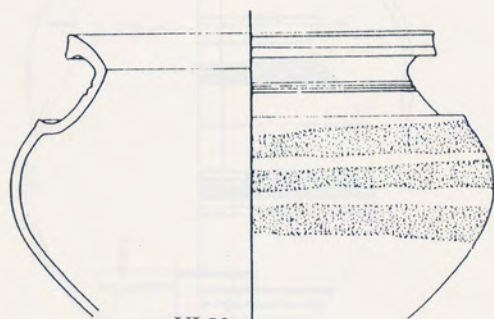

VI.50

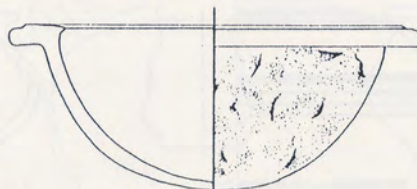

VI.55

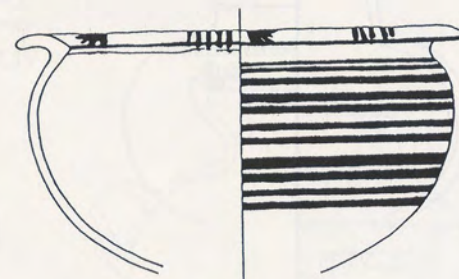

VI.54

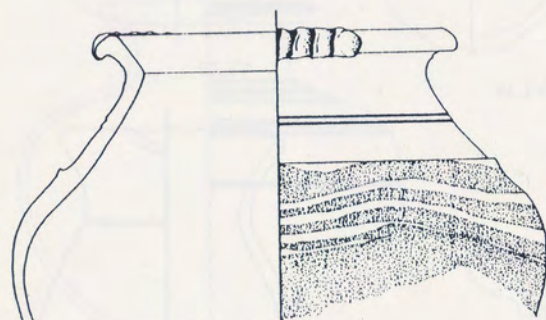

VI.53



VI.57

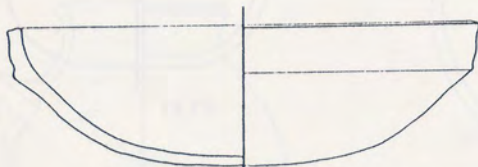

VI.56



VI.58

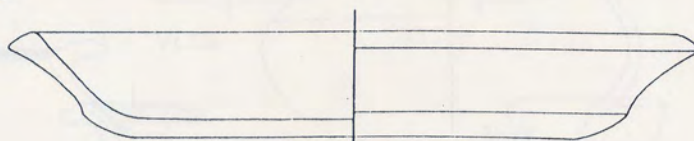

VI.61

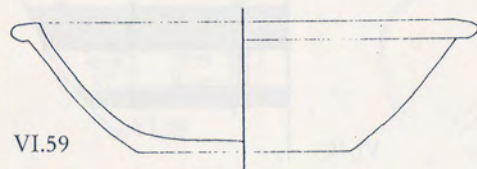

VI.59

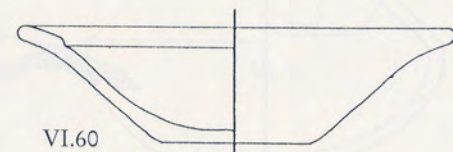

VI.60

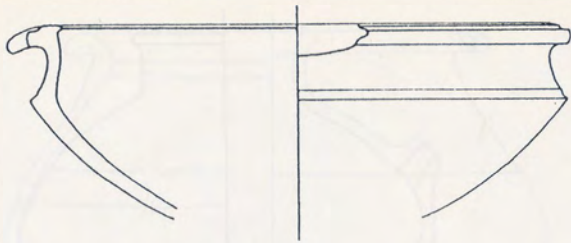

VI.62

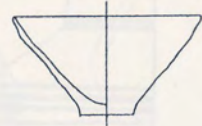

VI.65

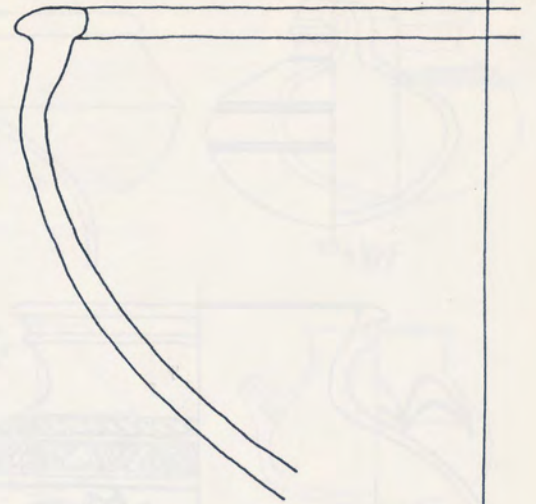

VI.64

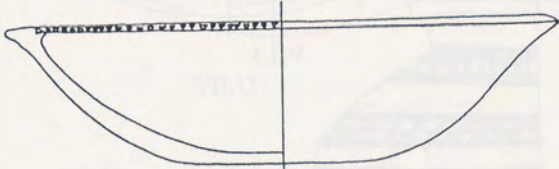

VI.63

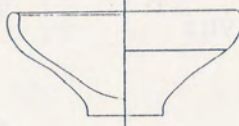

VI.66



VI.67



VI.69



VI.68

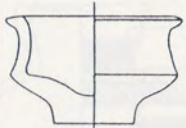

VI.70

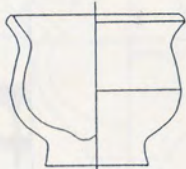

VI.71

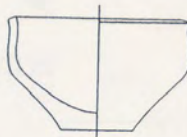

VI.72

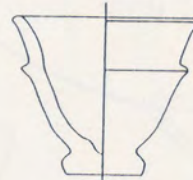

VI.73

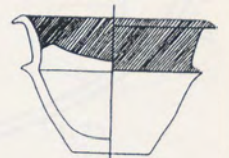

VI.74



VI.75



VI.76

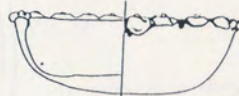

VI.77

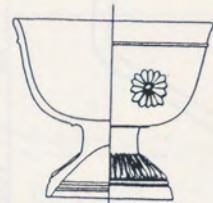

VI.78

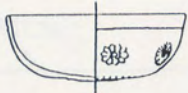

VI.79



VI.80

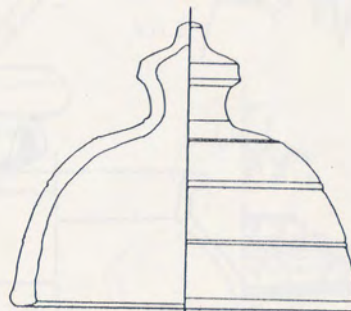

VI.84

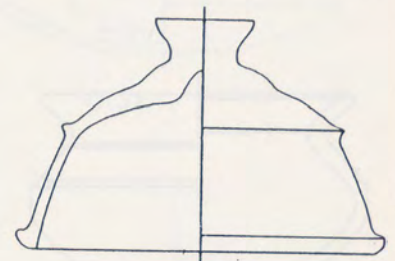

VI.83

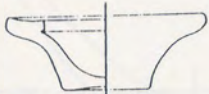

VI.82

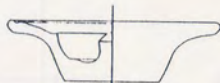

VI.81



VI.85

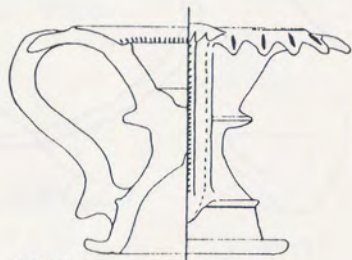

VI.86



VI.87

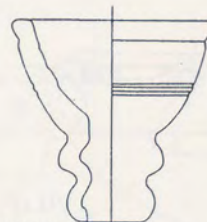

VI.88

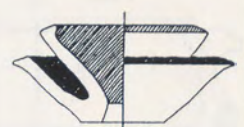

VI.89

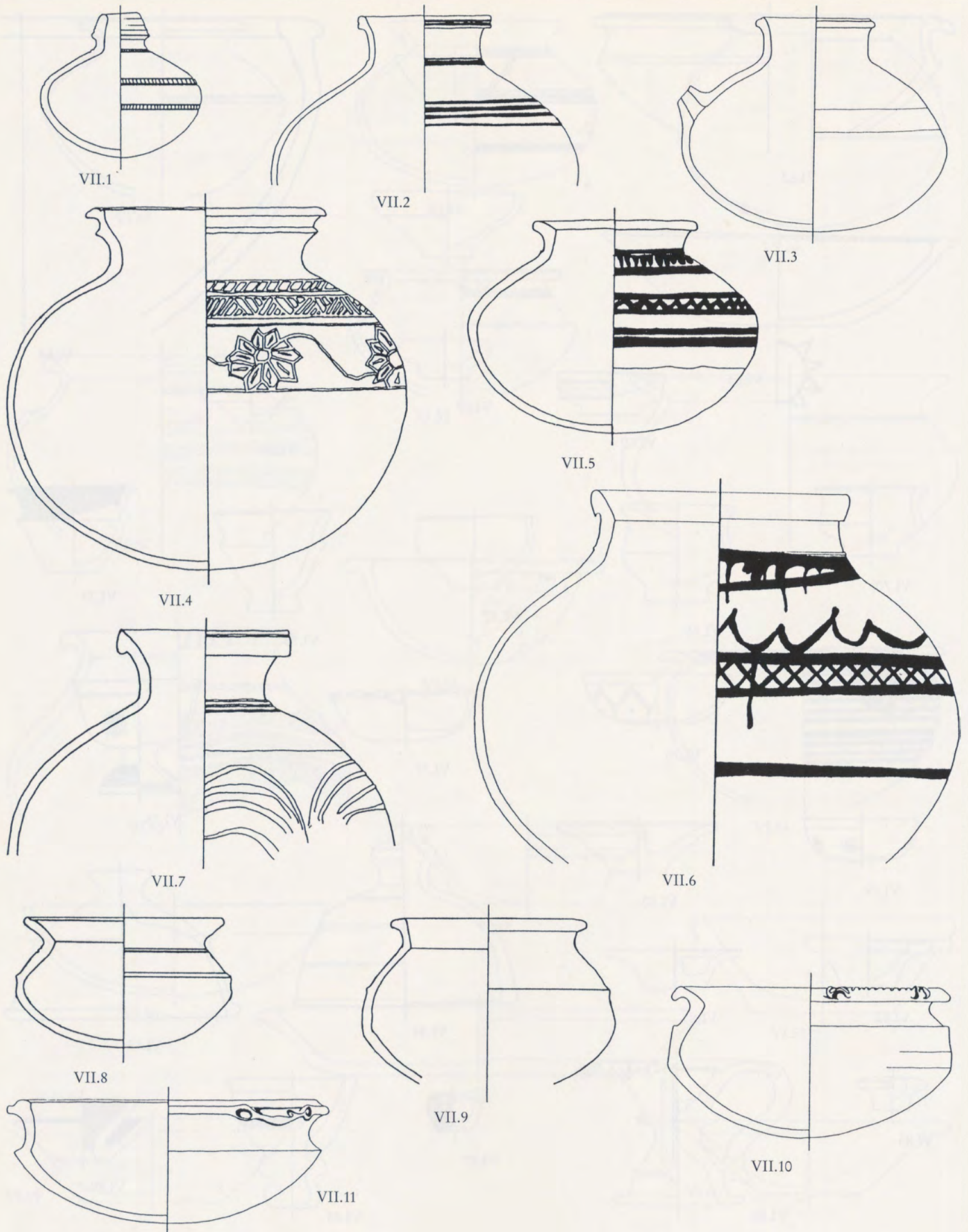

Pottery from Period VII. 1/4

Pottery from Period VII. 1/4

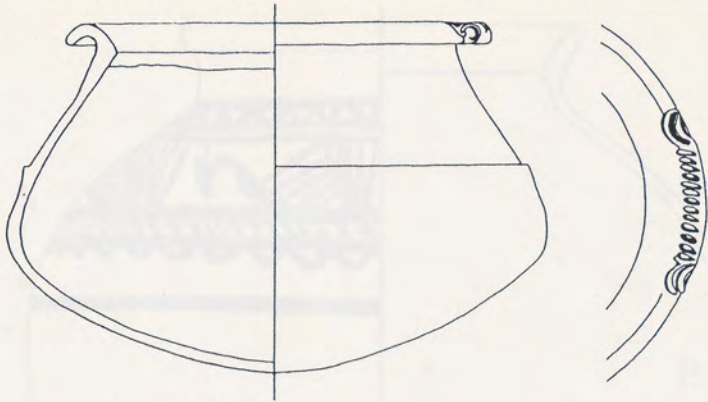

VII.12

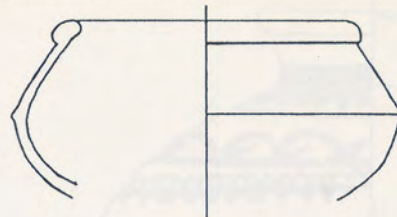

VII.13

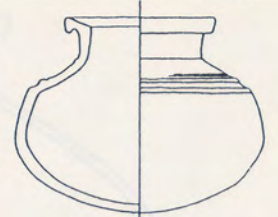

VII.14

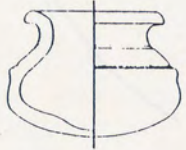

VII.15

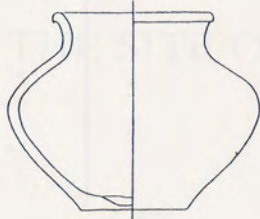

VII.16

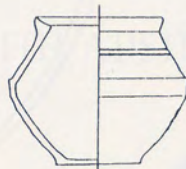

VII.17

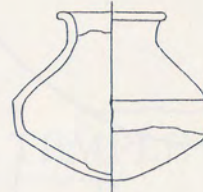

VII.18

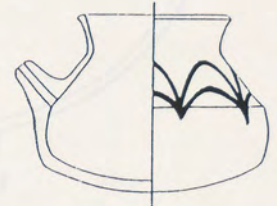

VII.19

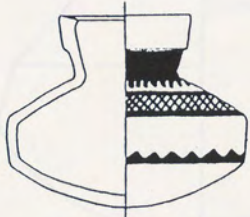

VII.20

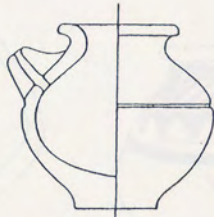

VII.21



VII.22



VII.23

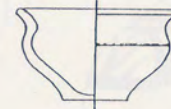

VII.24



VII.25

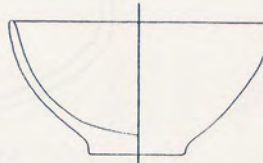

VII.29



VII.28

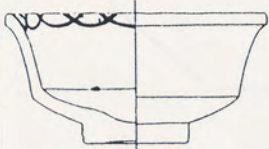

VII.26

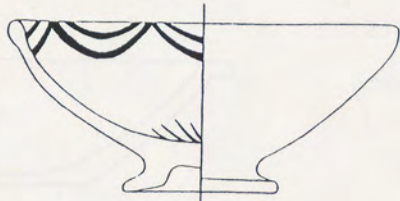

VII.32

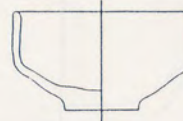

VII.27

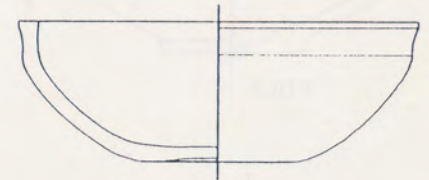

VII.30

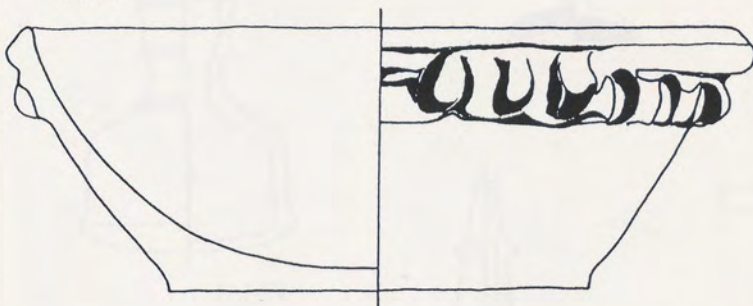

VII.33

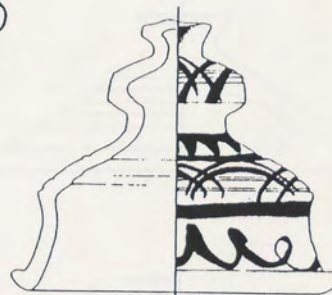

VII.34

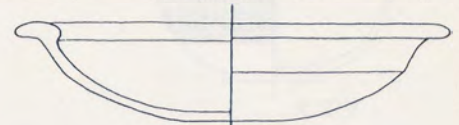

VII.31

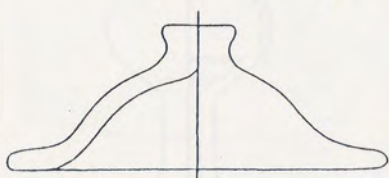

VII.36

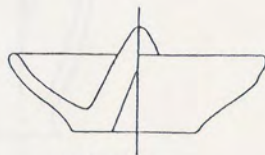

VII.37

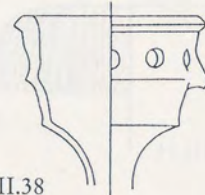

VII.38

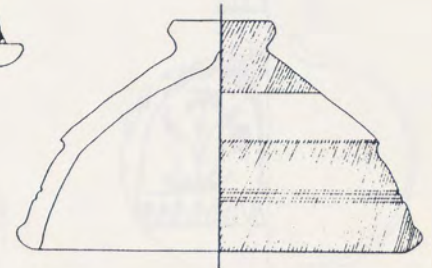

VII.35

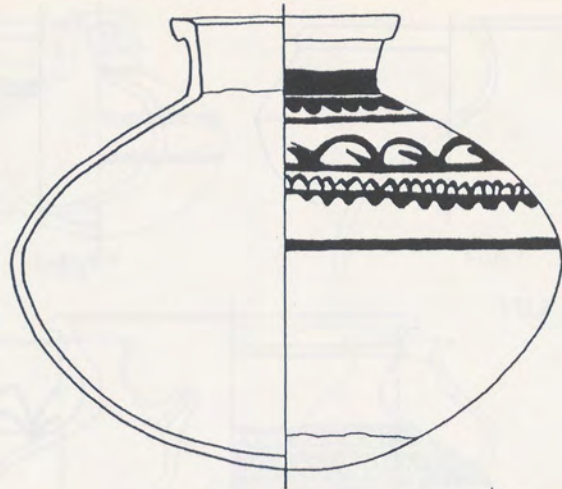

VIII.1



VIII.2

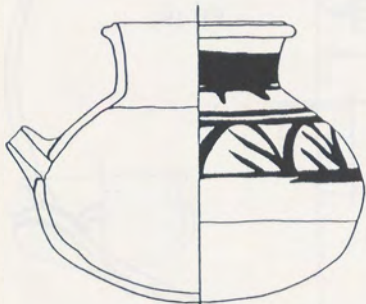

VIII.3

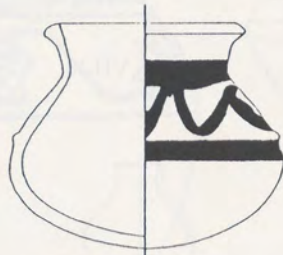

VIII.4

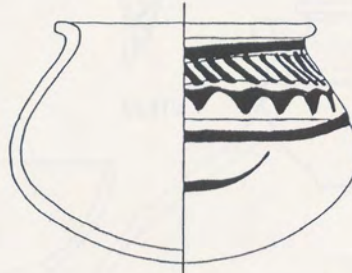

VIII.5

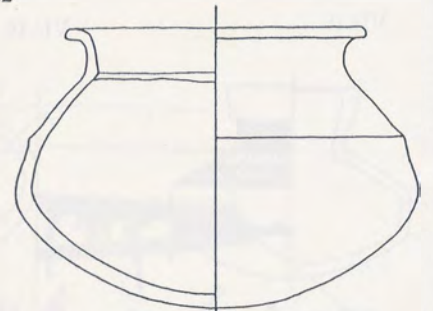

VIII.6

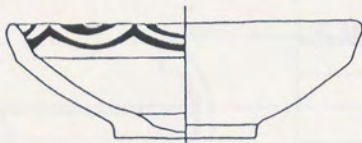

VIII.7

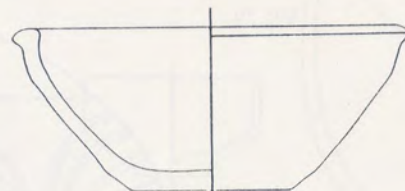

VIII.10

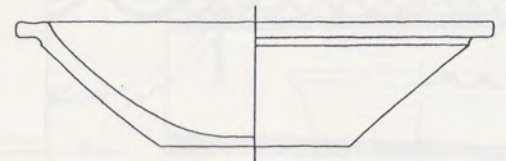

VIII.9

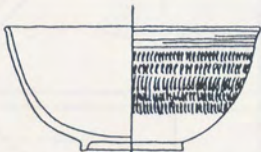

VIII.8



VIII.11

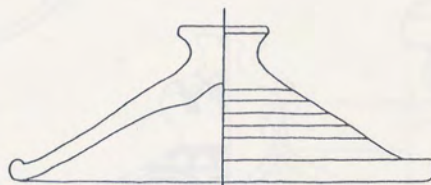

VIII.12



VIII.15

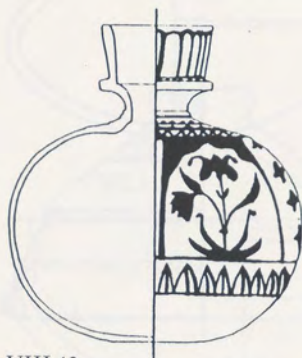

VIII.13

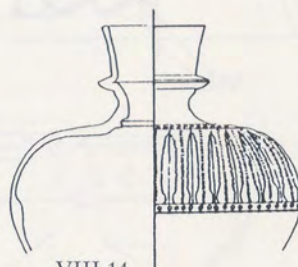

VIII.14



VIII.16

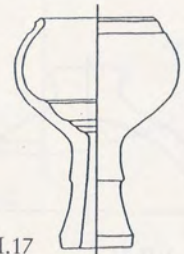

VIII.17